

HOSCO®

Instrument
PARTS

Catalog 2023



+ Accessories & Maintenance



HOSCO[®]

Catalog 2023

What does the mean?

If the category has the , it means that all the items in the category can be purchased with HOSCO packaging. Even though the category doesn't have the , if the item has the , it means the item can be purchased with HOSCO packaging.









The dimensions of drawings on this catalog are metric basically.

Send your order via



E-mail: contact@hosco.co.jp or Fax: +81-52-796-1630









INDEX





















Electronics Parts

Potentiometers	4	
CTS Control Potentiometers	4	
CTS Push-Pull DPDT Potentiometers	5	
Alpha Control Potentiometers	6	
Other Potentiometers	7	
Switches	8	
Covered Lever Switches	8	
Vintage style Lever Switches	8	
CRL Lever Switches	8	
Alpha Lever Switches	9	
Straight Toggle Switches	9	
Right-angle Toggle Switches	9	
Switchcraft Toggle Switches	10	
Mini Toggle Switches	10	
Switchcraft Slide Switches	10	
Plugs	11	
Switchcraft Plugs	11	
Jacks	11	
Flush-mount Jacks	11	
Endpin Jacks	11	
Switchcraft Endpin Jack	11	
Output Jacks	12	
Switchcraft Output Jacks	12	
Capacitors	12	
Oil Capacitors	12	
Polyester Film Capacitors	12	
Circuit Wires	13	
Lead Wires	13	
Multi-conductor Shielded Wires	13	
Cloth-covered Single Wires	13	
Mesh-shielded Single Wire	13	
Circuit Kits	14	
Circuit Kits w/CTS Potentiometers	14	
Circuit Kits w/Alpha Potentiometers	15	
Nuts / Washers	16	
Nuts	16	
Deep Thread Round Nut	16	
Flat Washers	16	
Lock Washers	17	
Packaged Nut/Washer/Lock Washer Sets	17	











Parts

Bridges	18	
Electric Guitar Bridges	18	
MG type Tremolo & Bridge	21	
JG/JM type Tremolo & Bridge	22	
Electric Bass Bridges	22	
Bridge Covers	23	
Archtop Guitar Bridges	24	
Acoustic Guitar Bridges	25	
Classical Guitar Bridges	25	
Bridge Pins	26	
Tailpieces	27	
Vibrola Tailpieces	27	
Archtop Guitar Tailpieces	27	
Jazz Guitar Tailpiece	28	
Electric Guitar Tailpieces	29	











Knobs	30	
Control Knobs for Guitars	30	
Control Knobs for Basses	35	
Rickenbacker® type Knobs	35	
Toggle Switch Knobs	35	
Lever Switch Knobs	36	
Arm Knobs	36	
Arm/Switch Knob Set	36	
Other Control Knobs	36	
Knob Assortment Sets	37	
Bodies	38	
Guitar Bodies	38	
Bass Bodies	43	
Necks	45	
Guitar Necks	45	
Neck Parts	45	
Neck Joint Ferrules	45	
Tonewoods	46	
Blank Bodies	46	
Blank Necks (for bolt on)	47	
Blank Fingerboards	47	
Kerfed Linings	47	
Fretwire	48	
Boxed Fretwire	48	
Coiled Fretwire	48	
Packaged Fretwire	49	
Truss Rods	50	
Two-way Truss Rods	50	
Martin® type Truss Rods w/Aluminum Channel	50	
Reinforcement Rods	51	
Truss Rod Parts	51	
Machine Heads	52	
Guitar Machine Heads	52	
Bass Machine Heads	53	
Bushings	53	
Nuts / Saddles	54	
Blank Bone Nuts	54	
Blank Bone Saddles	55	
Shaped/Slotted Bone Nuts	56	
Shaped Bone Saddles	57	
Visor Nut	57	
Sound Offset Spacers	58	
Brass Nuts	59	
Plastic Nut / Saddle Assortment Sets	60	
Pickup Parts	61	
Mounting Rings for Humbuckers	61	
Metal Mounting Rings for ST/TL	62	
Guitar Pickup Covers	63	
Bass Pickup Covers	65	
Pickup Fence	65	
Pickup Height Foam	65	
Pickup Springs	66	
Polepiece Screws	66	
Pickups	66	
Guitar Pickups	66	
Bass Pickups	72	

Pickguards	73	
Electric Guitar Pickguards	73	
Electric Bass Pickguards	79	
Aluminum Ground Materials	80	
Acoustic Guitar Pickguards	80	
Archtop Guitar Pickguards	81	
Pickguard Brackets	81	
Blank Sheets	82	
Faceguard	83	
Buckle Guard	83	
Plates	84	
Backplates	84	
Control Plates	85	
Neck Plate	86	
Treble/Rhythm Plates	86	
Jack Plates	87	
JG/JM type Related Parts	88	
Truss Rod Covers	88	
Other Bass Parts	88	
Finger Rest	88	
Endpins / Strap Buttons	89	
Strap Buttons for Electric Guitars / Basses	89	
Felt Washer	89	
Endpins for Acoustic Guitars	89	
Plastic Bridge Pin / Endpin Assortment Set	89	
Hardware	90	
Guitar Hardware	90	
Bass Hardware	90	
Bindings	91	
Patterned Bindings	91	
Plain Bindings	91	
Laminated Bindings	91	
Binding Glue	91	
Purflings	92	
Herringbone	92	
Patterned Purflings	92	
Inlays	92	
Precut Fingerboard Inlays	92	
Purfling Inlays	92	
Position Marks	93	
Position Dots	93	
Side Dot Materials	93	
Screws	94	
Master Relic Collection Screw Set	94	
Bridge/Tremolo Mounting Screws	95	
Mounting Ring Screws	96	
Pickguard Screws	96	
Pickup Mounting Screws	97	
Plate/Cover Screws	97	
Endpin Screws	98	
String Retainer Screws	98	
Tailpiece Screws	98	
Switch Mounting Screws	98	
Truss Rod Cover Screw	98	
Tuner Screws	99	
Battery Box Screws	99	
Wrenches	100	
Allen Wrenches	100	
Truss Rod Wrenches	100	

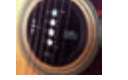

Other String Instrument Parts

Resonator Guitar Parts	101	
Resonator Guitar Bridges	101	
Resonator Cones	101	
Coverplate	101	
Extension Nut	101	
Saddles	102	
Sound Ring	102	
Resonator Guitar Tailpiece	102	
Resonator Guitar Machine Heads	102	
Banjo Parts	103	
Banjo Armrests	103	
Banjo Bracket Wrenches	103	
Banjo Bridge	103	
Banjo Hook / Nut Set	103	
Banjo Tailpieces	104	
Blank Bone Nut	104	
Coordinator Rod Set	104	
Resonator Flange / Tube	105	
Resonator Hardware Sets	105	
Tension Hoop	105	
Mandolin Parts	106	
Blank Bone Nut	106	
Mandolin Tailpieces	106	
Mandolin Bridges	106	
Mandolin Pickguards	106	
Ukulele Parts	107	
Blank Bone Nut	107	
Kerfed Linings	107	
Violin Parts	107	

Accessories

Picks	108	
Thumb Picks	108	
Finger Picks	108	
Flat Picks	109	
Mandolin Picks	110	
Mutes	111	
MyMute™	111	
Violin Mute	111	
Capo	111	
Banjo 5th Capo	111	
Slide Bars	111	
Stevens Steel Bars	111	
Care / Cleaning	112	
Wiping Cloths	112	
Easy Fret Care	113	
Humidity Controllers	114	
Hygro-Thermometers	115	
HOSCO Hygro-Thermometers	115	

Relic Parts

Master Relic Collection	116	
ST type Parts	116	
TL type Parts	117	
ST/TL type Parts	118	
LP type Parts	118	
PB type Parts	119	

Potentiometers



CTS Control Potentiometers

CTS is the most famous potentiometers in the music industry.
For all of our CTS pots, Nut x1, Washer x1, and Lock washer x1 included.



What is great on HOSCO's CTS pots?

Please see the comparison pictures below.
Hosco's CTS pots have a unique shaft.
It might be a little difference, but it prevents knobs from being cracked.
Save your knobs with Hosco's CTS pots!

Common CTS pots

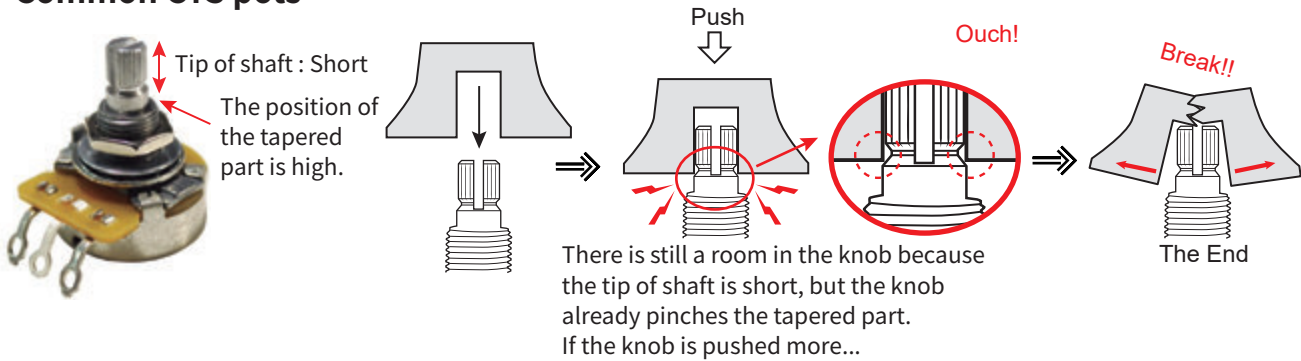

HOSCO's CTS pots (except CTS-MM and Push-Pull)

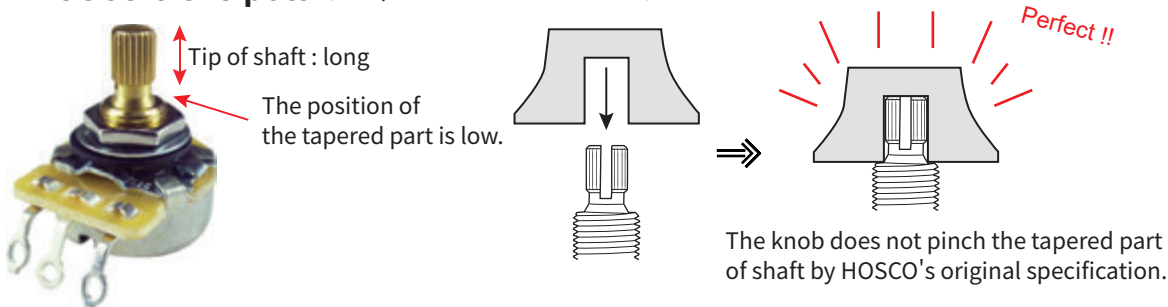

Regular Shaft (Inch)

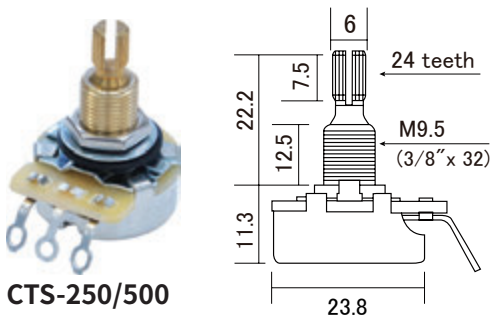

CTS-250/500

Item#	Description
CTS-A250	Regular shaft, 250K, A type
CTS-B250	Regular shaft, 250K, B type
CTS-A500	Regular shaft, 500K, A type
CTS-B500	Regular shaft, 500K, B type

A type : Audio taper / B type : Linear taper
Fits our Inch sized knobs. (See pages 26-32)

Short Shaft (Inch)

For mounting onto pickguards.
If you don't like a gap between knobs and pickguards, please choose this short shaft.

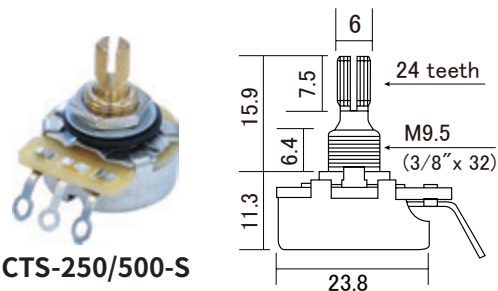

CTS-250/500-S

Item#	Description
CTS-A250-S	Short shaft, 250K, A type
CTS-B250-S	Short shaft, 250K, B type
CTS-A500-S	Short shaft, 500K, A type
CTS-B500-S	Short shaft, 500K, B type

A type : Audio taper / B type : Linear taper
Fits our Inch sized knobs. (See pages 26-32)

Long Shaft (Inch)

For mounting onto archtop guitar bodies like LP.

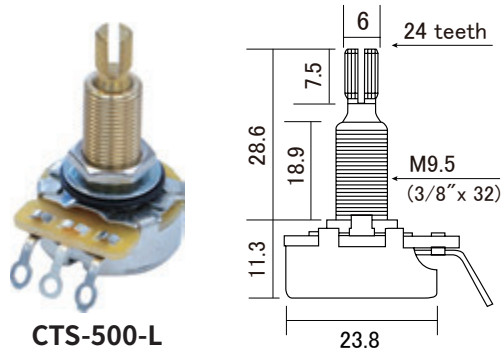

Item#	Description
CTS-A500-L	Long shaft, 500K, A type
CTS-B500-L	Long shaft, 500K, B type

A type : Audio taper / B type : Linear taper
Fits our Inch sized knobs. (See pages 26-32)

Short & Solid Shaft (Inch)

For using metal knobs like TL.

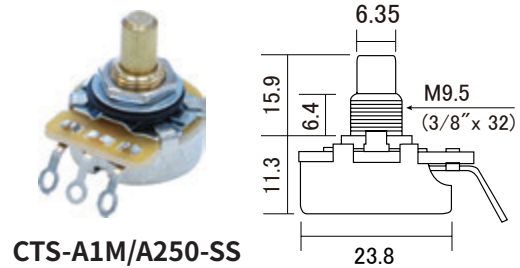

Item#	Description
CTS-A1M-SS	Short & Solid shaft, A type, 1MEG
CTS-A250-SS	Short & Solid shaft, A type, 250K

A type : Audio taper
Fits our Inch sized knobs. (See pages 26-32)

Regular Shaft (Metric)

Most of the CTS pots in the musical instrument industry are made in the inch unit system.

Even if you preferred CTS quality, you would have needed to make some minor adjustment when you replaced the metric pots with CTS.

Now remember to have these CTS in metric.

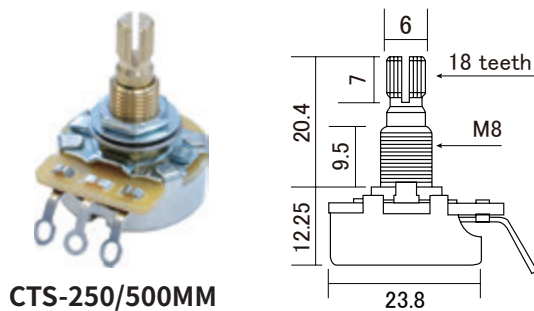

Item#	Description
CTS-A250MM	Metric regular shaft, 250K, A type
CTS-B250MM	Metric regular shaft, 250K, B type
CTS-A500MM	Metric regular shaft, 500K, A type
CTS-B500MM	Metric regular shaft, 500K, B type

A type : Audio taper / B type : Linear taper
Fits our Metric sized knobs. (See pages 26-32)

CTS Push-Pull DPDT Potentiometers

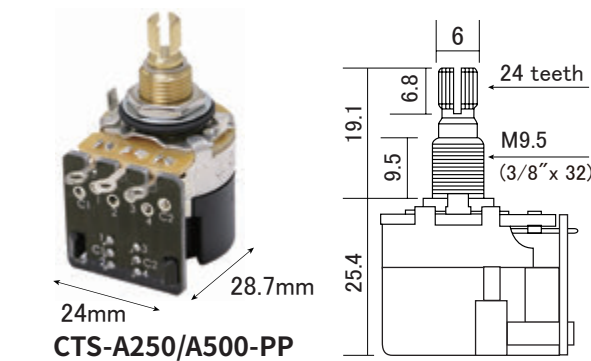

Item#	Description
CTS-A250-PP	Regular split shaft, A type, 250K
CTS-A500-PP	Regular split shaft, A type, 500K

A type : Audio taper
Fits our Inch sized knobs. (See pages 26-32)

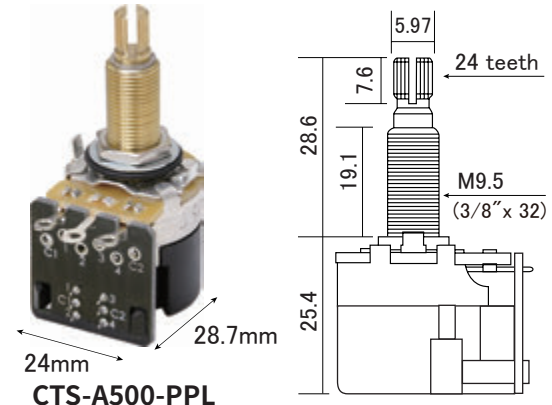

Item#	Description
CTS-A500-PPL	Long split shaft, A type, 500K

A type : Audio taper
Fits our Inch sized knobs. (See pages 26-32)

Alpha Control Potentiometers



The electronics by Alpha are famous for its reasonable price and high reliability all over the world. Aluminum split shaft for 18 teeth knurled knobs. 1 nut and 1 washer included.

Standard 24mm dia. Potentiometers



ALP-250/500/25K

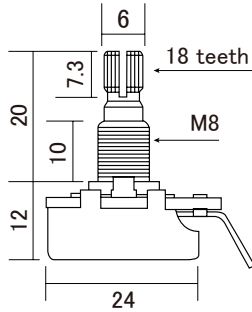

Item#	Description
ALP-250A	250K, A type
ALP-250B	250K, B type
ALP-500A	500K, A type
ALP-500B	500K, B type
ALP-25KA	25K, A type
ALP-25KB	25K, B type

A type : Audio taper / B type : Linear taper

Mini 16mm dia. Potentiometers



ALP-2501/5001

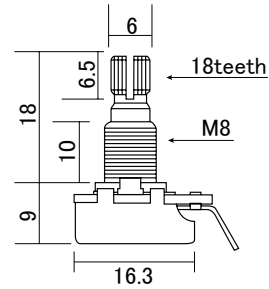

Item#	Description
ALP-2501	250K, A type
ALP-2501B	250K, B type
ALP-5001	500K, A type
ALP-5001B	500K, B type

A type : Audio taper / B type : Linear taper

Mini 16mm dia. Potentiometers for JM/J Solid shaft.

Item#	Description
ALP-1M1B-S	1MEG, B type
ALP-501KB-S	50K, B type

B type : Linear taper

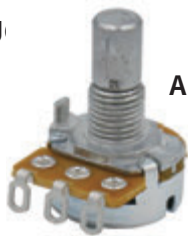

ALP-1M1B-S

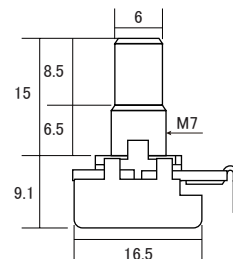

Other Potentiometers

Blend Potentiometers

Blend pots control the signal mix from two sources, panning from one source to another. Fits our metric sized knobs. 1 nut and 1 washer included.

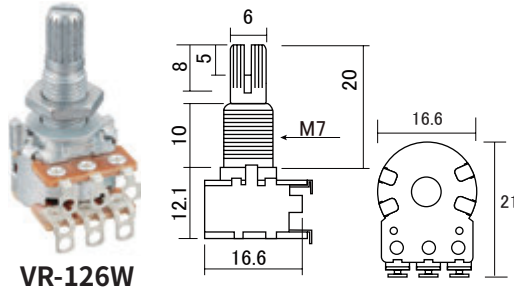

VR-126W

Item#	Description
VR-126W250	250K
VR-126W500	500K

Push-Pull Control Potentiometers

Push-pull pots for electric guitars. Fits our metric sized knobs. 1 nut and 1 washer included.

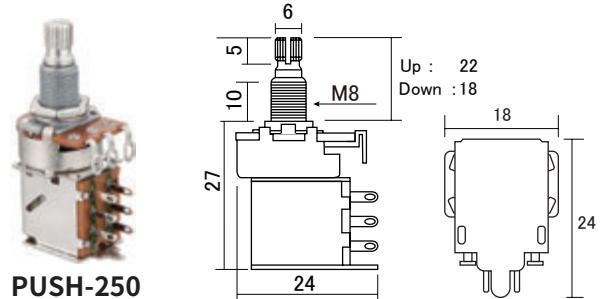

PUSH-250

Item#	Description	Item#	Description
PUSH-250A	250K, A type	PUSH-500A	500K, A type
PUSH-250B	250K, B type	PUSH-500B	500K, B type

A type : Audio taper / B type : Linear taper

Push-Push Potentiometers

Push-push pots for electric guitars. Fits our metric sized knobs. 1 nut and 1 washer included.

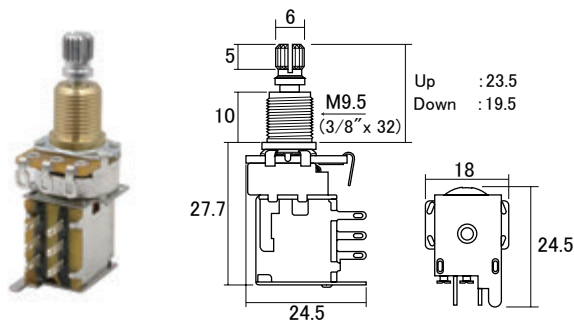

PUSHPUSH-250A

Item#	Description
PUSHPUSH-250A	250K, A type
PUSHPUSH-250B	250K, B type
PUSHPUSH-500A	500K, A type
PUSHPUSH-500B	500K, B type

A type : Audio taper / B type : Linear taper



Just push it!



You can switch the wiring while holding a pick.

Switches

HOSCO[®]
Pack

Covered Lever Switches

Covered type, nickel contacts.
Fits our metric sized knobs.
Purchase switch knobs separately.
Screws included.

Item#	Description
YM-30S	3-way
YM-50S	5-way

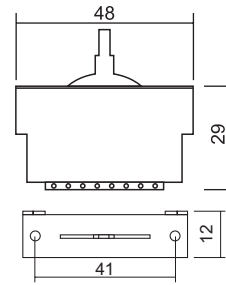

Electronics

Parts

Vintage style Lever Switches

Vintage style lever switches. Made in Japan.
Two contacts available, nickel and gold.
Fits our metric sized knobs.
Purchase switch knobs separately.
Screws included.

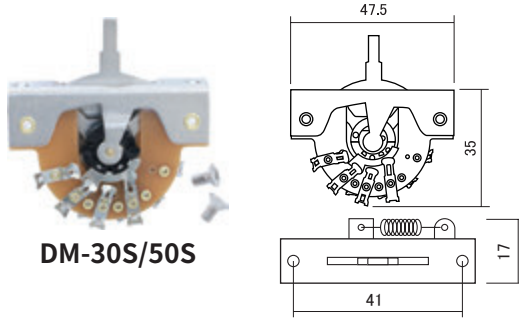

DM-30S/50S

Item#	Description
DM-30S	3-way, w/Nickel contacts
DM-30GS	3-way, w/Gold contacts
DM-50S	5-way, w/Nickel contacts
DM-50GS	5-way, w/Gold contacts

We have been successful in improving the quality of the DM-30/50 lever switches by thickening the terminals.

Other String
Instrument Parts

Accessories

Maintenance

Relic Parts

CRL Lever Switches

Vintage style lever switches. Made in USA.
Fits our INCH sized knobs.
Purchase switch knobs separately.
Screws included.

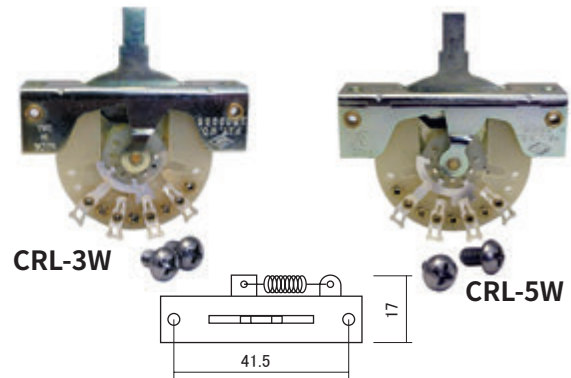

CRL-3W

CRL-5W

Item#	Description
CRL-3W	3-way
CRL-5W	5-way

Alpha Lever Switches



The electronics by Alpha are famous for its reasonable price and high reliability all over the world. Fits our metric sized knobs. Purchase switch knobs separately. Screws included.

Item#	Description
ALP-3W	3-way
ALP-5W	5-way

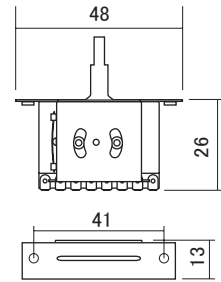
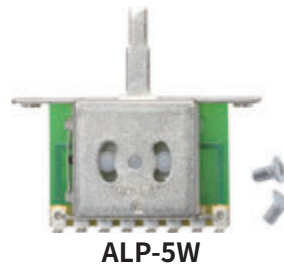

Straight Toggle Switches

3-way switches for LP type guitars and the other 2-pickup guitars.

Fits our metric sized knobs.
Purchase switch knobs separately. (for YM-T20R and YM-T20GGR)
1 knurled nut and 1 washer included.

Item#	Description
YM-T20R	Nickel contacts, No knob
YM-T20B	Nickel contacts, w/Black brass knob
YM-T20C	Nickel contacts, w/Chrome brass knob
YM-T20G	Nickel contacts, w/Gold brass knob
YM-T20G-2	Nickel contacts, w/*Gold-plated parts
NEW YM-T20B-2	Nickel contacts, w/*Black-plated parts

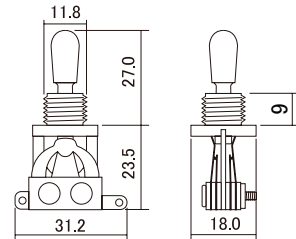

Item#	Description
YM-T20GGR	Gold contacts, No knob

*Gold-plated parts : Knob, nut, washer, lever, & threaded portion
*Black-plated parts : Knob, nut, washer, lever, & threaded portion

Right-angle Toggle Switches

3-way switches for LP type guitars and 2-pickup or 3-pickup guitars.

Fits our metric sized knobs.
Purchase switch knobs separately.
1 knurled nut and 1 washer included.

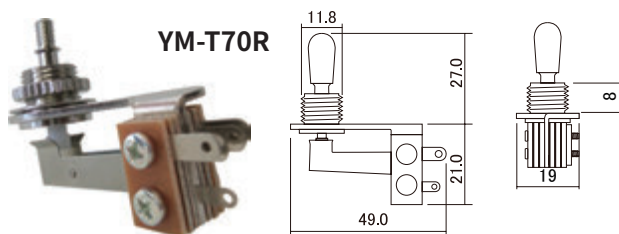

YM-T70R

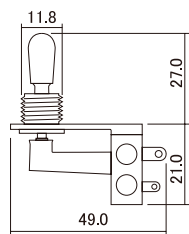

Item#	Description
YM-T70R	for 2-pickup guitars



YM-T75R

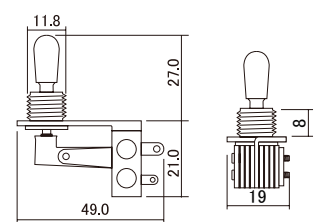

Item#	Description
YM-T75R	for 3-pickup guitars

Switchcraft Toggle Switches

3-way switches for LP type guitars and the other 2-pickup guitars.
Made in USA.

The Switchcraft toggle switches come with 1 knob, but its color cannot be chosen.
1 knurled nut and 1 washer included.

Switchcraft®

Item#	Description
SWC-TR	Right-angle
SWC-TS	Straight
SWC-TS-S	Straight, Short

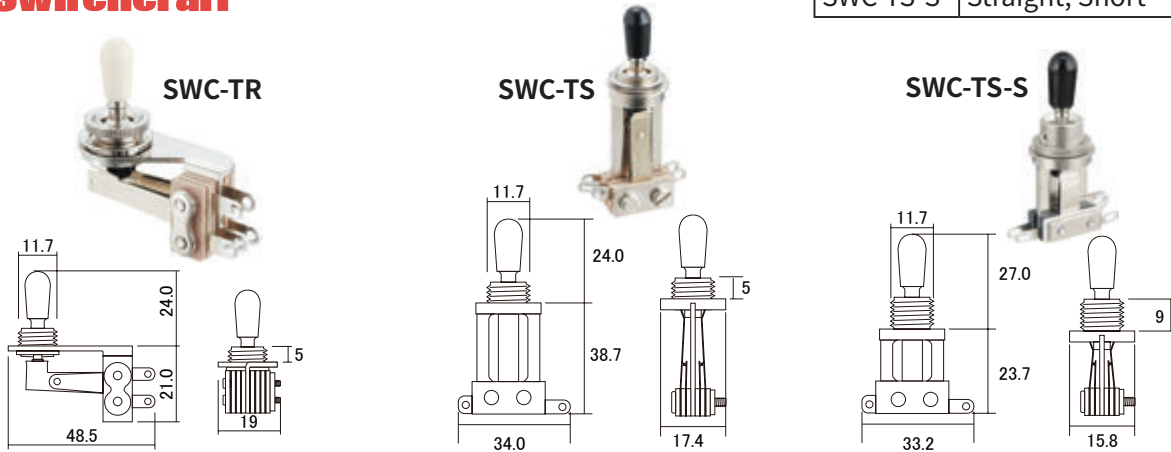

Deep Thread Round Nuts

For Switchcraft® toggle switches

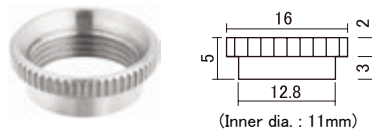
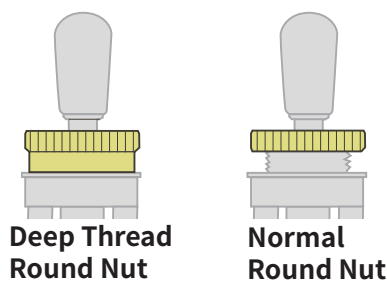

DTRN-N

Item#	Description
NEW DTRN-G	Gold
NEW DTRN-N	Nickel

The threaded part is longer and it can be tightened firmly.

Mini Toggle Switches

DPDT. 2 nuts, 1 lock washer, & 1 flat washer included.

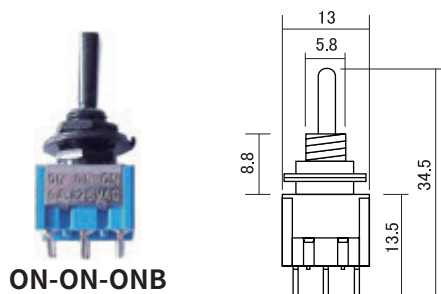

Item#	Description
ON-OFF-ONB	On-Off-On, Black
ON-OFF-ONC	On-Off-On, Chrome
ON-ON-ONB	On-On-On, Black
ON-ON-ONC	On-On-On, Chrome
ON-ONB	On-On, Black
ON-ONC	On-On, Chrome

Switchcraft Slide Switches

Screw hole spacing for On-Off-On : 1-13/32" (Approx. 35.72mm)
Screw hole spacing for On-On : 1-1/8" (Approx. 28.58mm)
2 screws included.

Switchcraft®

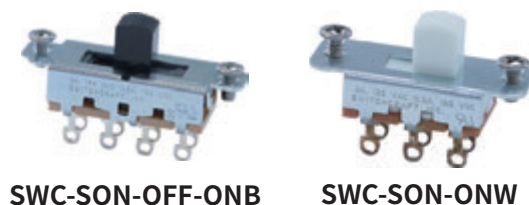

Item#	Description
SWC-SON-OFF-ONB	On-Off-On, for MG, Black
SWC-SON-OFF-ONW	On-Off-On, for MG, White
SWC-SON-ONB	On-On, for JM/JG, Black
SWC-SON-ONW	On-On, for JM/JG, White

Plugs HOSCO[®] Pack

Switchcraft Plugs

Switchcraft[®]

Item#	Description
PL-14R	1/4" Right-angle, Mono phone plug
PL-14S	1/4" Straight, Mono phone plug



Jacks HOSCO[®] Pack

Flush-mount Jacks

For solidbody guitars.
1 nut and 1 washer included.

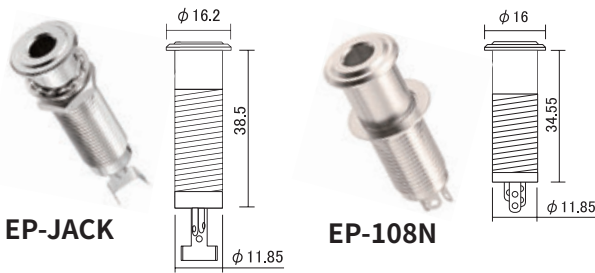

Item#	Description
EP-JACK	Stereo, Nickel
EP-108B	Stereo, Black
EP-108G	Stereo, Gold
EP-108N	Stereo, Nickel

Endpin Jacks

Can be installed from outside the guitar. (EP-JACK2)
Nickel only.

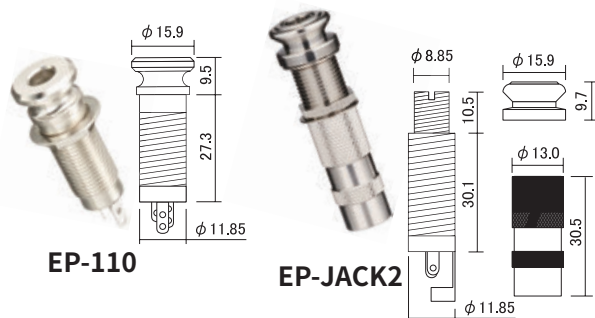

Item#	Description
EP-110	Stereo, w/1 nut and 1 washer
EP-JACK2	Stereo, w/2 nuts, 1 washer, 1 lock washer, & 1 rubber ring

Switchcraft Endpin Jack

For 1/4" phone plug. 3 conductors for stereo.
Can be installed from outside the guitar.

Item#	Description
SWC-EPJACK	Stereo, Nickel

2 nuts, 2 washers, and 1 lock washer included.

Switchcraft[®]

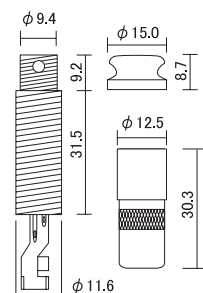

Electronics

Parts

Other String Instrument Parts

Accessories

Maintenance

Relic Parts

Output Jacks

These output jacks can be used for various kinds of electric guitars and basses. 2 nuts and 1 washer included.



OJ-50

Item#	Length	Dia.
OJ-50	8mm	9mm
OJ-65	9mm	9mm

Item#	Description
OJ-50	Mono, Short, Nickel



OJ-65

OJ-65G

Item#	Description
OJ-65	Mono, Nickel
OJ-65G	Mono, Gold

Gold-plated parts : Threaded portion, 1 nut, & 1 washer

Switchcraft Output Jacks

These output jacks can be used for various kinds of electric guitars and basses. 2 nuts and 1 washer included.

Switchcraft®



OJ-120

Item#	Length	Dia.
OJ-120	7mm	9.4mm
OJ-120S	7mm	9.4mm
OJ-120G	7mm	9.4mm
OJ-120L	9mm	9.4mm

Item#	Description
OJ-120	Mono, Nickel
OJ-120G	Mono, Gold

Item#	Description
OJ-120L	Mono, Long, Nickel
OJ-120S	Stereo, Nickel

Capacitors

HOSCO®
Pack

Oil Capacitors

The decoration is small and light by the insulation sleeve. Made in Japan.

Rated Voltage Range : 630Vdc

Withstand Voltage : Rated Voltage x 200%

0.022 μ f for Humbucker, 0.047 μ f for Single coil.

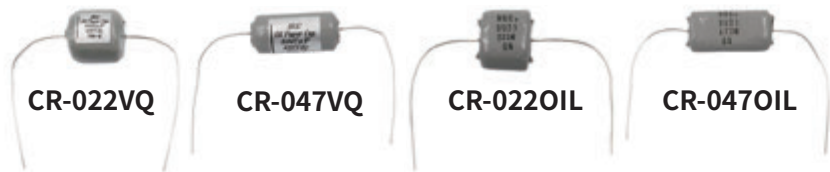
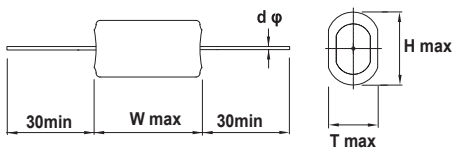

Item#	W	T	H	d.
CR-022VQ	18.0mm	18.0mm	18.0mm	0.6mm
CR-047VQ	28.0mm	12.0mm	12.0mm	0.6mm
CR-022OIL	18.0mm	15.5mm	19.5mm	0.6mm
CR-047OIL	28.0mm	9.5mm	15.0mm	0.6mm

Item#	Description
CR-022VQ	Cylinder type, 0.022 μ f, \pm 10%
CR-047VQ	Cylinder type, 0.047 μ f, \pm 10%
CR-022OIL	Slim type, 0.022 μ f, \pm 20%
CR-047OIL	Slim type, 0.047 μ f, \pm 20%

Polyester Film Capacitors

0.022 μ f for Humbucker, 0.047 μ f for Single coil.

Made in Japan. MOQ : 100 pcs each.

Item#	Description
CR-223	0.022 μ f
CR-473	0.047 μ f



Circuit Wires

HOSCO®
Pack

Lead Wires

AWG26. 100cm (39-1/2") long.

Item#	Description
CBL-LWBK100	Black
CBL-LWYE100	Yellow
CBL-LWOR100	Orange
CBL-LWRD100	Red
CBL-LWWH100	White

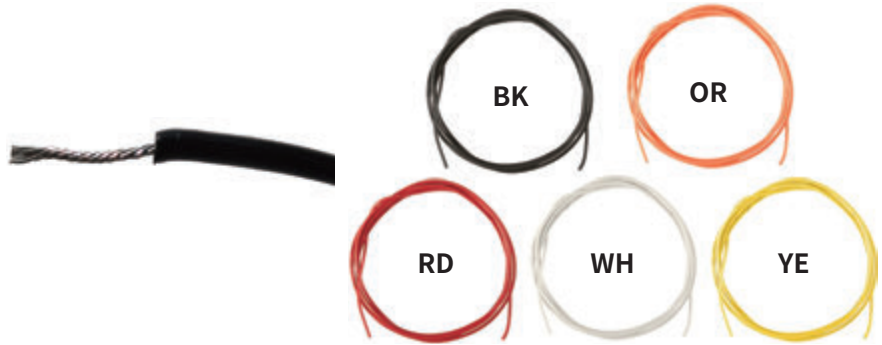

Multi-conductor Shielded Wires

Shielded. 100cm (39-1/2") long.

Item#	Description
CBL-2CW100	2-conductor wire
CBL-3CW100	3-conductor wire
CBL-4CW100	4-conductor wire

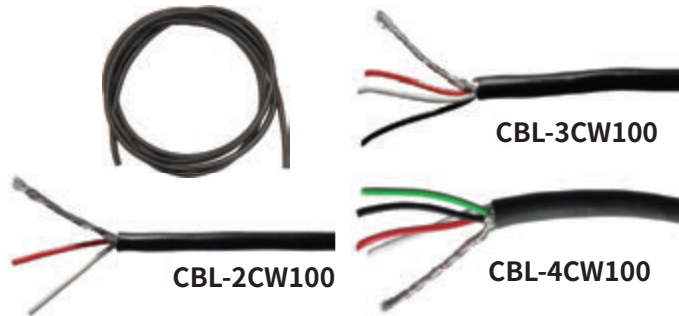

Cloth-covered Single Wires

AWG22. Non-shielded. Waxed braided cotton outer. 100cm (39-1/2") long.



CBL-100CLB



CBL-100CLW

Item#	Description
CBL-100CLB	Black
CBL-100CLW	White

Mesh-shielded Single Wire

Shielded. 100cm (39-1/2") long.



CBL-100MS

Item#	Description
CBL-100MS	Mesh-shielded wire

Electronics

Parts

Other String
Instrument Parts

Accessories

Maintenance

Relic Parts

Circuit Kits

Circuit Kits w/CTS Potentiometers



These circuit kits consist of CTS pots and Japanese-made parts like switches, jacks, wires, and so on. Wiring diagram included.



HKC-CKLP-B (LP type w/Black parts)

500K audio pots	x 4
Toggle switch	x 1
including knob & plate	
Output jack	x 1
Capacitors (0.022μf)	x 2
Single wires	x 5
3-conductor wire	x 1



HKC-CKLP-I (LP type w/Cream parts)

500K audio pots	x 4
Toggle switch	x 1
including knob & plate	
Output jack	x 1
Capacitors (0.022μf)	x 2
Single wires	x 5
3-conductor wire	x 1



HKC-CKJB (JB type)

250K audio pots	x 3
Output jack	x 1
Capacitor (0.047μf)	x 1
Single wires	x 4



HKC-CKPB (PB type)

250K audio pots	x 2
Output jack	x 1
Capacitor (0.1μf)	x 1
Single wires	x 4

Electronics

Parts

Other String Instrument Parts

Accessories

Maintenance

Relic Parts

Circuit Kits w/Alpha Potentiometers

HOSCO®
Pack

ALPHA

Alpha electronics have been used to many guitars or basses in the world and the quality is stable and reliable. All of these circuit kits include Alpha pots and some of them do Alpha lever switches. The other parts are mostly made in Japan. Wiring diagram included.

**HKA-CKST (ST type)**

250K audio pots	x 3
5-way switch	x 1
including Black & White knobs & screws	
Output jack	x 1
Capacitor (0.047µf)	x 1
Single wires	x 8

**HKA-CKTC (TL type)**

250K audio pots	x 2
3-way switch	x 1
including knob & screws	
Output jack	x 1
Capacitors (0.047µf & 0.001µf)	x 2
Single wires	x 5

**HKA-CKLP-B
(LP type w/Black parts)**

500K audio pots	x 2
500K linear pots	x 2
Toggle switch	x 1
including knob & plate	
Output jack	x 1
Capacitor (0.022µf)	x 2
Single wires	x 5
3-conductor wire	x 1

**HKA-CKLP-I
(LP type w/Cream parts)**

500K audio pots	x 2
500K linear pots	x 2
Toggle switch	x 1
including knob & plate	
Output jack	x 1
Capacitors (0.022µf)	x 2
Single wires	x 5
3-conductor wire	x 1

**HKA-CKJB (JB type)**

250K audio pots	x 3
Output jack	x 1
Capacitor (0.047µf)	x 1
Single wires	x 4

**HKA-CKPB (PB type)**

250K audio pots	x 2
Output jack	x 1
Capacitor (0.1µf)	x 1
Single wires	x 4

Nuts / Washers HOSCO® Pack

Nuts

NU-5 is the same nut that is originally attached to YM-T20/T70R/T75R toggle switches.
 NU-6 is the same nut that is originally attached to CTS pots (Inch-size).

MOQ : 100 pcs each

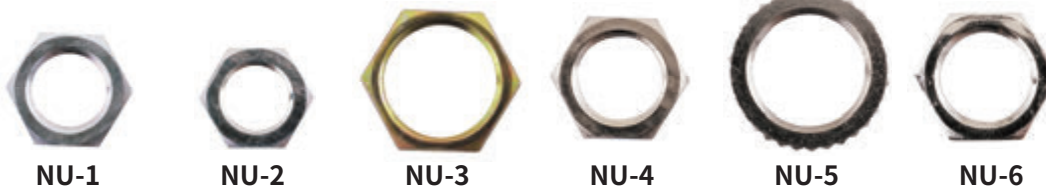

Item#	Inner Dia.	Outer Dia.	For	Note
NU-1	7mm	11mm	Push-Pull pots, Alpha pots, CTS-MM pots (Metric)	M8
NU-2	6mm	10mm	VR-126W, Alpha pots (16mm Solid)	M7
NU-3	11mm	14mm	EP-JACK / 108 / 110, YM-T20 / T70R / T75R	M12
NU-4	8mm	12mm	OJ-50 / 65	M9
NU-5	11mm	16mm	YM-T20 / T70R / T75R	Knurled Nut
NU-6	8.6mm	12.5mm	CTS pots (Inch), OJ-120	3/8"

Deep Thread Round Nut

Aren't toggle switches prone to loosening? They are operated frequently, and in some cases, depending on the thickness of the mounting area, the screws may not be so tight. If you are not careful, this can lead to wire breakage. This "Deep Thread Round Nut" is the savior for such troubled toggle switches. The Deep Thread Round Nut is a revolutionary product that extends the threading while maintaining the appearance of a normal round nut when installed.

This product is compatible with toggle switches made by Switchcraft®. It cannot be used for other toggle switches made in Japan or other millimeter-standard toggle switches.



DTRN-N

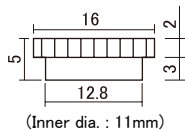

NEW

NEW

Item#	Description
DTRN-G	Gold
DTRN-N	Nickel

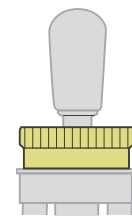

Deep Thread Round Nut

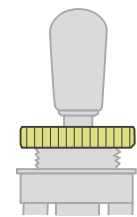

Normal Round Nut

The threaded part is longer and it can be tightened firmly.

Flat Washers

WH-3 is the same washer that is originally attached to YM-T20/T70R/T75R toggle switches.
 WH-4 is the same washer that is originally attached to OJ-50/65 output jacks.
 WH-5 is the same washer that is originally attached to CTS pots (Inch-size).

MOQ : 100 pcs each



Item#	Inner Dia.	Outer Dia.	For
WH-1	8mm	13.5mm	Push-Pull pots, Alpha pots, CTS-MM pots (Metric)
WH-2	7mm	12mm	VR-126W, Alpha pots (16mm Solid)
WH-3	12mm	18mm	EP-JACK / 108 / 110, YM-T20 / T70R / T75R
WH-4	9mm	14mm	OJ-50 / 65, OJ-120
WH-5	9mm	15.7mm	CTS pots (Inch)

Lock Washers

LW-5 is the same lock washer that is originally attached to CTS pots (Inch-size).

MOQ : 100 pcs each



Item#	Inner Dia.	Outer Dia.	For
LW-1	8mm	15mm	CTS-MM pots (Metric), Push-Pull pots, Alpha pots
LW-2	7mm	13mm	VR-126W, Alpha pots (16mm Solid)
LW-3A	12mm	21mm	EP-JACK / 108 / 110, YM-T20 / T70 / T75
LW-3B	12mm	15mm	EP-JACK / 108 / 110, YM-T20 / T70 / T75
LW-4	10mm	17mm	OJ-50 / 65 / 120
LW-5	9.5mm	17mm	CTS pots (Inch)

Packaged Nut/Washer/Lock Washer Sets



These sets for nuts, washers, and lock washers always come with HOSCO packaging.

Metric-size



Item#	For	Finish	Nut	Washer	Lock Washer
EXNUT-EPB	Endpin Jacks	Black	NU-3B x 1 / NU-3 x 1	WH-3B x 1	LW-3A x 1
EXNUT-EPN	Endpin Jacks	Nickel	NU-3 x 2	WH-3 x 1	LW-3A x 1
EXNUT-OJB	Output Jacks	Black	NU-4B x 1 / NU-4 x 1	WH-4B x 1	LW-4 x 1
EXNUT-OJN	Output Jacks	Nickel	NU-4 x 2	WH-4 x 1	LW-4 x 1
EXNUT-POTN	24mm dia. Pots	Nickel	NU-1 x 2	WH-1 x 1	LW-1 x 1
EXNUT-VRN	16mm dia. Pots	Nickel	NU-2 x 2	WH-2 x 1	LW-2 x 1
EXNUT-YMTB	Toggle Switches	Black	NU-5B x 1 / NU-3 x 1	WH-3B x 1	LW-3B x 1
EXNUT-YMTN	Toggle Switches	Nickel	NU-5 x 1 / NU-3 x 1	WH-3 x 1	LW-3B x 1

Inch-size



Item#	For	Finish	Quantities
EXWSI-PJ	Pots & Jacks	N/A	Washer x 4
EXLWI-PJ	Pots & Jacks	N/A	Lock Washer x 4
EXNI-PJC	Pots & Jacks	Chrome	Nut x 4
EXNSI-PJG	Pots & Jacks	Gold	Nut x 1 / Washer x 1

Bridges

Electric Guitar Bridges



HOSCO Original TL Bridges by GOTOH®

The only one side wall cut baseplate and fixing with the two small additional screws provide a better stability on the bridge. Moreover, GOTOH®'s In-Tune saddles make more exact intonation compared to traditional ones. Dual-loading. Screws included.



HK-24NS

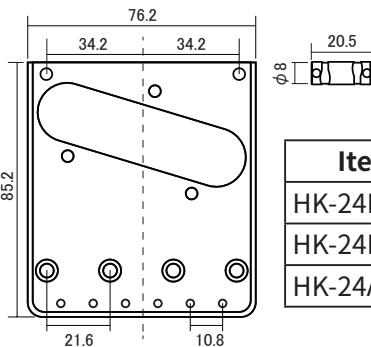

Item#	Description
HK-24NS/BS	Nickel, w/Brass saddles
HK-24NS/TI	Nickel, w/Titanium saddles
HK-24ACS/BS	Aged Chrome, w/Brass saddles

Vintage style TL Bridge w/3 Saddles



Baseplate : Steel
Saddles : Brass
Screws included.

T-21C

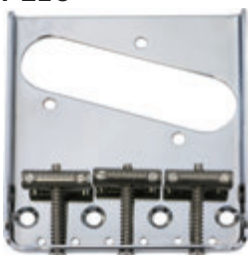

Saddles : Brass
(Nickel-plated)

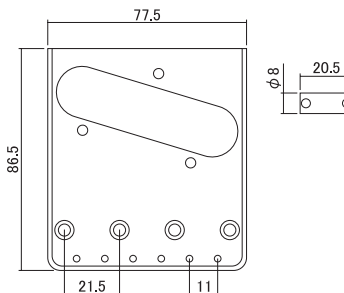
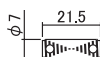
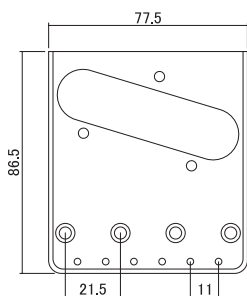

HK-22CS

HK-23CS



Saddles : Brass (Unplated)
The only one difference is Angle of the saddles for the HK-22CS and HK-23CS.

Compensated Barrel Saddle Set



The Brass saddles come with intonation screws and springs.
Sold as a set of 3.

Item#	Description
HK-22SSS	Compensated barrel saddle set, 3/SET



HK-22SSS

TL Bridge w/Shorter Plate

Baseplate : Steel
Saddles : Brass
Screws included.

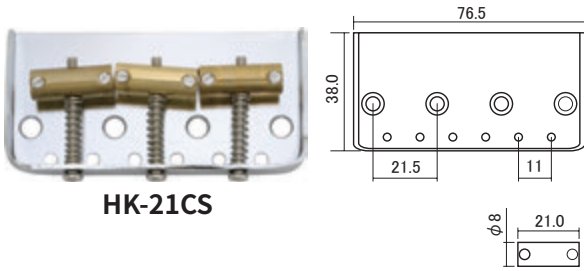

HK-21CS

Item#	Description
HK-21CS	Chrome, w/3 compensated saddles

TL Bridges for Humbucker PU

Baseplate : Steel
Saddles : Steel
Screws included.

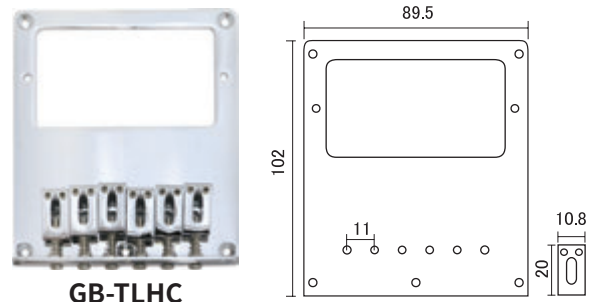

GB-TLHC

Item#	Finish
GB-TLHC	Chrome
GB-TLHG	Gold

Vintage style TL Bridge w/6 Saddles

The shape of string slots on the saddles is "V-shape" that makes some good benefits.
Screws included.

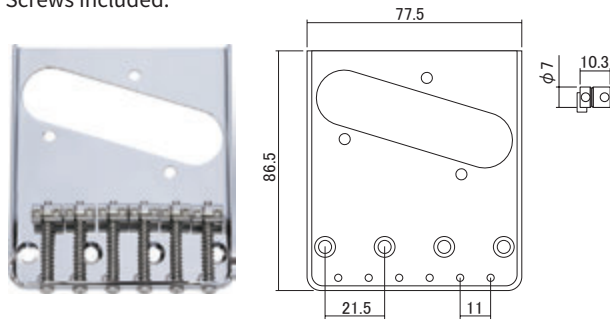

Item#	Description
T-40C	Satin Chrome, w/6 barrel saddles

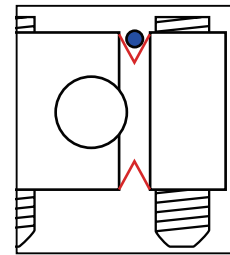

V-shape

"V-shape" = two point support
It brings us the following merits!

- * Reduction of a buzz tone
- * Tuning stability
- * Proper string tension
- * Quicker response
- * Bigger clear sound

Vintage style Jr. Bridge

Allen screws can adjust the overall string length.
Material : Brass
Studs and bushings included.

Item#	Description
HK-TV2	Chrome, w/metric threaded studs (M8x1.25)

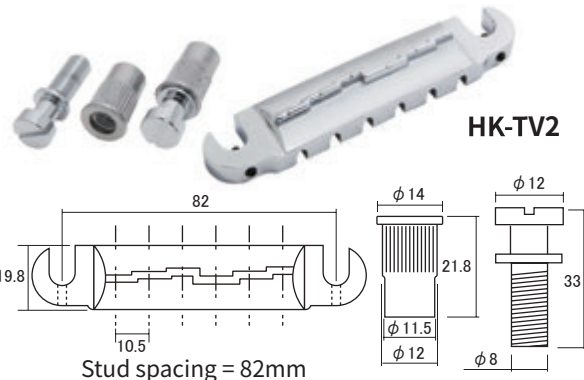

HK-TV2

Stud spacing = 82mm

Wraparound Guitar Bridge

Overall string length can be adjusted.
Studs and bushings included.

Item#	Finish
GB-BDSC	Chrome

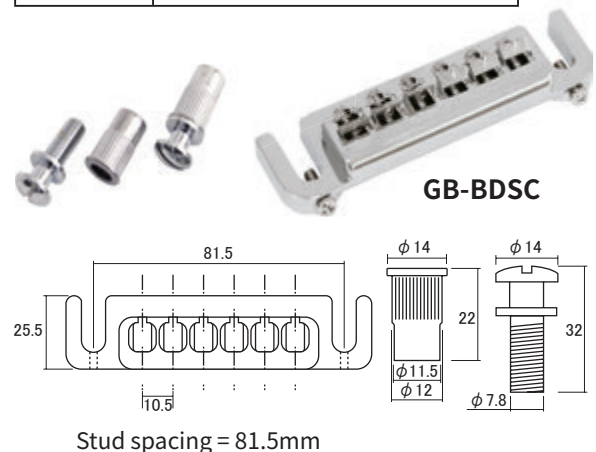

GB-BDSC

Stud spacing = 81.5mm

GOTOH® T-O-M Bridges w/Brass Saddles

GE103B and GE103B-T bridges with “Brass” saddles are available from Hosco. The brass saddles are finished in the same plating as the bridges. Chrome, Nickel, and Gold. Posts & thumbwheels or Studs & bushings included. Bulk for manufacturers only.

Packaged

Item#	Description
H-GE103BC-BS	GE103B, Chrome
H-GE103BG-BS	GE103B, Gold
H-GE103BN-BS	GE103B, Nickel
H-GE103BTC-BS	GE103B-T, Chrome
H-GE103BTG-BS	GE103B-T, Gold
H-GE103BTN-BS	GE103B-T, Nickel

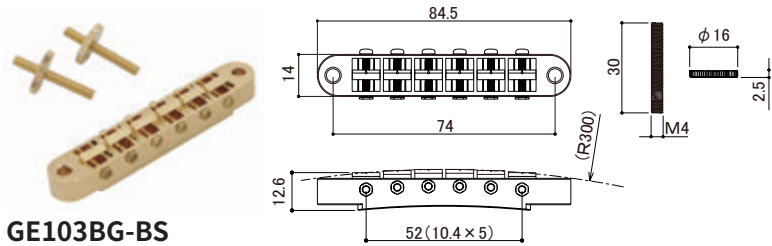

GE103BG-BS

Bulk

Item#	Description
GE103BC-BS	GE103B, Chrome
GE103BG-BS	GE103B, Gold
GE103BN-BS	GE103B, Nickel
GE103BTC-BS	GE103B-T, Chrome
GE103BTG-BS	GE103B-T, Gold
GE103BTN-BS	GE103B-T, Nickel

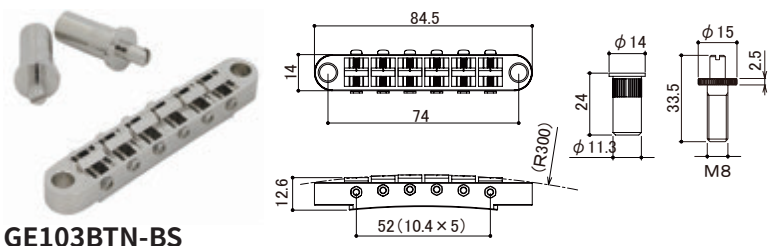

GE103BTN-BS

Vintage style T-O-M Bridges

ABR-1 type. The adjustable intonation screws are held with a wire.
 Bridge : Zinc
 Saddles : Brass (No notch)
 Posts & thumbwheels included.

Item#	Finish
HK-25C	Chrome
HK-25N	Nickel
HK-25G	Gold

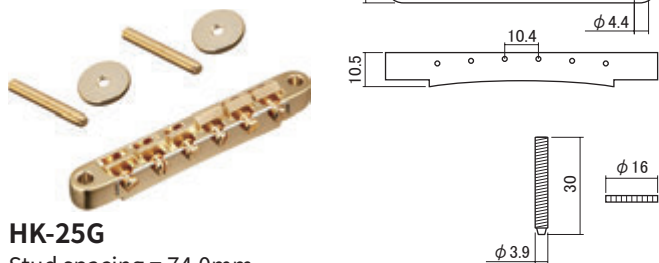

HK-25G
 Stud spacing = 74.0mm

Modern style T-O-M Bridges

Nashville type with wider intonation adjustment.
 Bridge : Zinc
 Saddles : Zinc (No notch)
 Studs and bushings included.

Item#	Finish
HK-120C	Chrome
HK-120N	Nickel
HK-120G	Gold

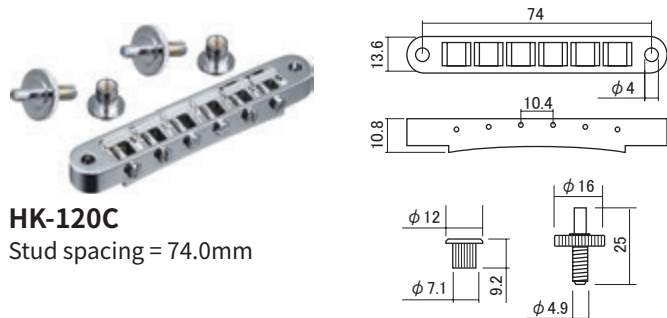

HK-120C
 Stud spacing = 74.0mm

GOTOH® Vintage style T-O-M Bridges with 12" radius



300mm (Approx. 12") radius
 The 12" radius is used on most of LP type electric guitars.
 You can match the radius on both of fingerboard and bridge.

Vintage look
 The narrow shape looks good on vintage guitars.
 Our special GE104B bridge has both of 12" radius and vintage look.

Unnotched Brass saddles
 Longer sustain and warm sound.
 You can adjust the string spacings as you like.



GE104BC-BS300

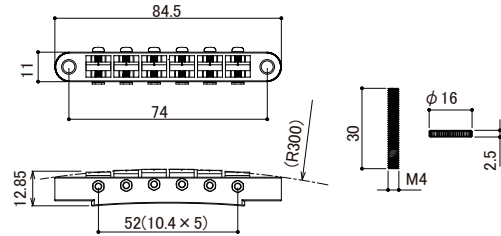

	Item#	Description
NEW	GE104BC-BS300	GE104B, Chrome
NEW	GE104BG-BS300	GE104B, Gold
NEW	GE104BN-BS300	GE104B, Nickel
NEW	GE104BAN-BS300	GE104B, Aged Nickel

The Hosco packaged version is also available for retailers.

MG type Tremolo & Bridge



MG type Tremolo

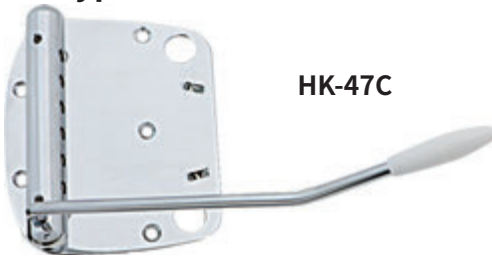

HK-47C

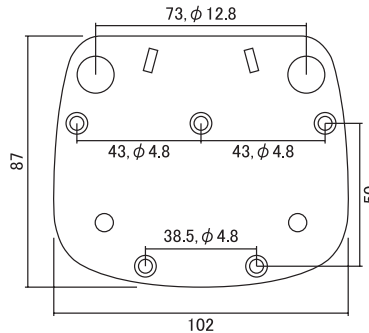

Material : Steel. Screws included.

Item#	Description
HK-47C	Tremolo unit, Chrome, w/arm
HK-47A	Tremolo arm only (White arm knob)
HK-47A/65	Tremolo arm only (Black arm knob), '65 style angle



HK-47A

HK-47A/65

MG type Bridge

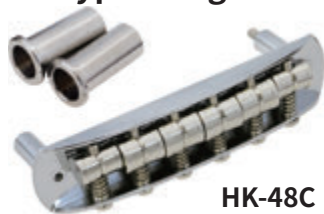

HK-48C

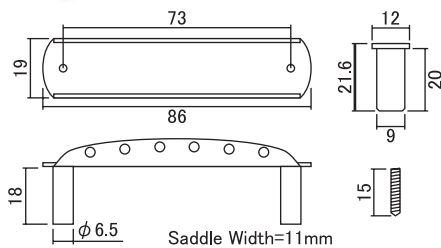

Item#	Description
HK-48C	Bridge, Chrome, w/bushings

MG type Saddle Set for another use

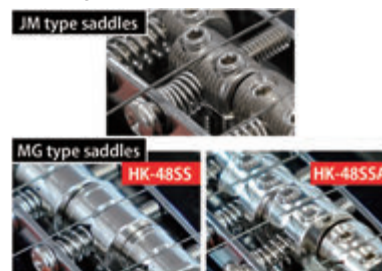

JG/JM type saddles are usually equipped with a spiral type saddles with shallow grooves, but to prevent string drop, simply replace it with Mustang® (MG) type saddles with deep grooves. (There are some cases where this is not possible due to size standards in millimeters or inches, compatibility of parts, etc.).



HK-48SS

HK-48SSA

These saddle sets can be used on JM type bridge as well and they can prevent the strings from running off.

	Item#	Description
NEW	HK-48SS	Saddle Set, 6/SET, Height-unadjustable
NEW	HK-48SSA	Saddle Set, 6/SET, Height-adjustable

JG/JM type Tremolo & Bridge

HOSCO Pack

JG/JM type Tremolo

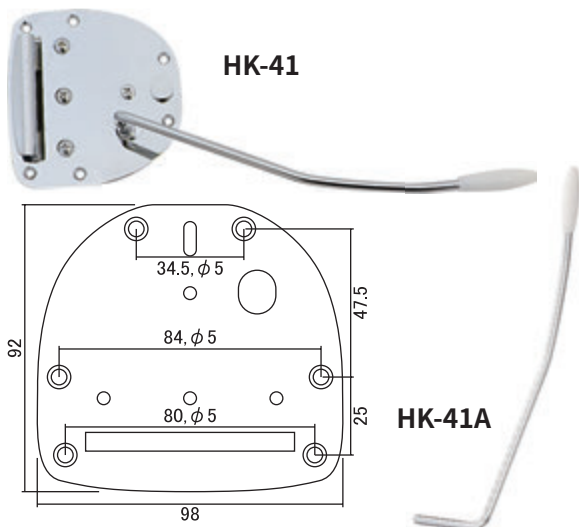

Material : Steel. Screws included.

Item#	Description
HK-41	Tremolo unit, Chrome, w/arm
HK-41A	Tremolo arm only (White arm knob)

JG/JM type Bridge

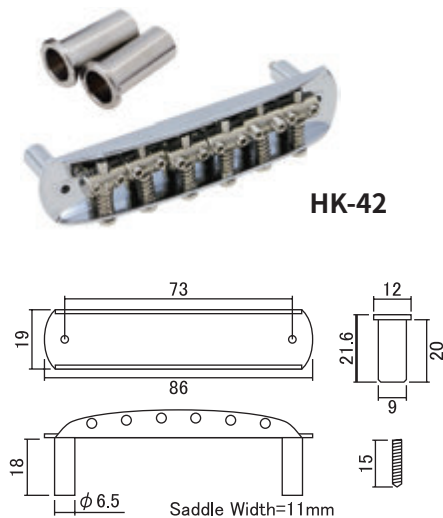

Material : Steel. Screws included.

Item#	Description
HK-42	Bridge, Chrome, w/bushings

Electric Bass Bridges

HOSCO Pack

Wilkinson Bass Bridge

HOSCO Pack

The two saddles can be rotated to get a better intonation.
Saddles : Brass
Screws included.

Item#	Finish
WB2V-NS	Nickel

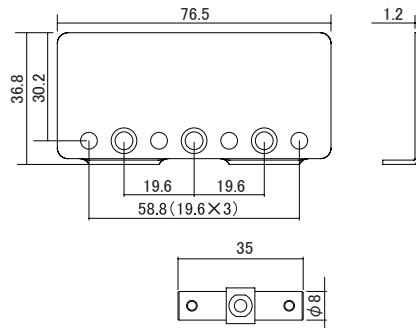

3-point Bass Bridges

HOSCO Pack

Material : Zinc
Studs and bushings included.



Item#	Description
HK-30BS	Black, w/3 studs
HK-30NS	Nickel, w/3 studs

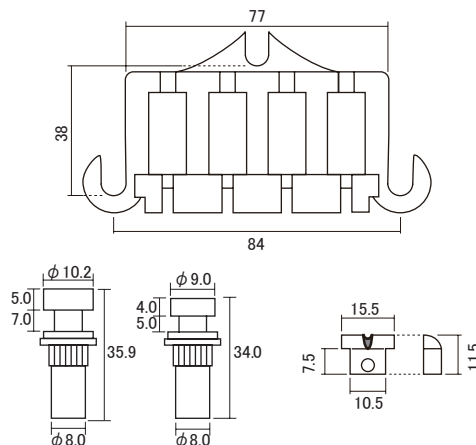

Standard Bridges for PB/JB HOSCO[®] Pack

Baseplate & Saddles : Steel
 String spacing : 60.0mm (20.0mm x 3)
 Screws included.

Item#	Finish
HK-20BS	Black Nickel
HK-20CS	Chrome
HK-20GS	Gold

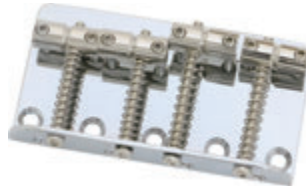

HK-20CS

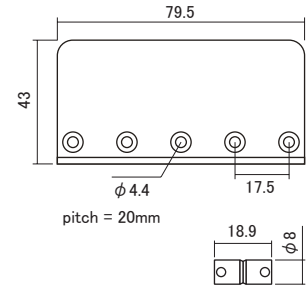

Standard Bridge w/Spiral Saddles HOSCO[®] Pack

Baseplate : Steel
 Saddles : Brass
 String spacing : 60.0mm (20.0mm x 3)
 Screws included.

Item#	Description
T-117N/S	Nickel, w/spiral saddles

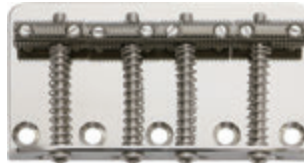

T-117N/S

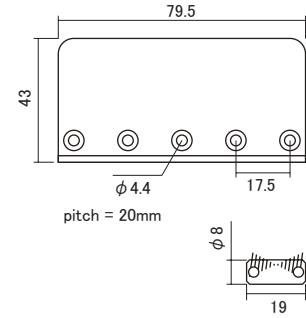

Bridge Covers HOSCO[®] Pack

TL Bridge Cover

Stamped bridge cover. Fits our HK-22, HK-23, T-21, and T-40.

Item#	Finish
T-50C	Chrome

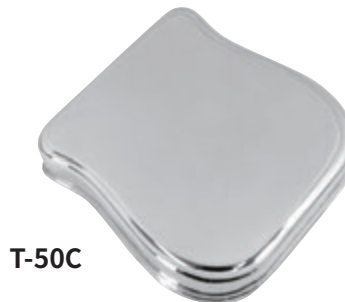

T-50C

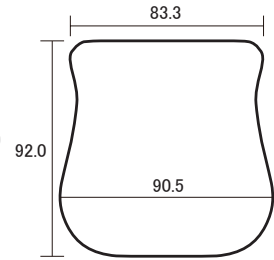

PB Bridge Cover

Screws included.

Item#	Finish
BC-PC	Chrome



BC-PC

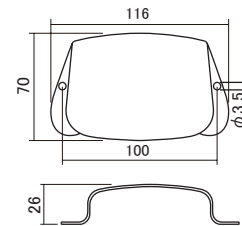

JB Bridge Cover

Screws included.

Item#	Finish
BC-JC	Chrome



BC-JC

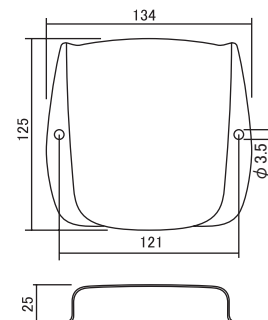

Archtop Guitar Bridges



Machined bridges for archtop guitars. The saddle is unnotched.
150mm(L) x14mm(W) x 23.5mm(H).

F-2803 , F-2804 & F-2813 come with compensated saddle and F-2805 & F-2806 come with slanted saddle. Only Posts & thumbwheels : Gold or Nickel

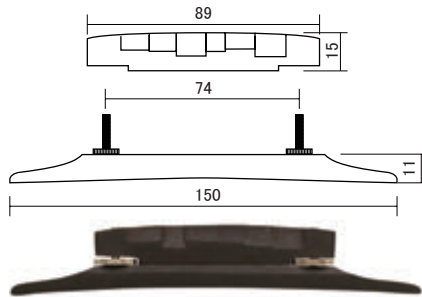

F-2803

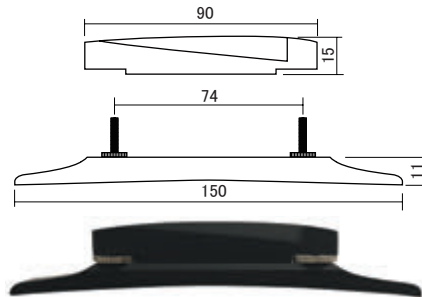

F-2805

Archtop Bridges w/Compensated Saddle

Item#	Description
F-2803	Ebony, Nickel
F-2803R	Rosewood, Nickel
F-2804	Ebony, Gold
F-2804R	Rosewood, Gold

Archtop Bridges w/Slanted Saddle

Item#	Description
F-2805	Ebony, Nickel
F-2805R	Rosewood, Nickel
F-2806	Ebony, Gold
F-2806R	Rosewood, Gold

Archtop Bridges w/T-O-M

GOTOH® GE104B is installed on the contoured base.
String spacing : 52.0mm (10.4mm x 5)
T-O-M Bridge & Saddles : Zinc



F-2820E

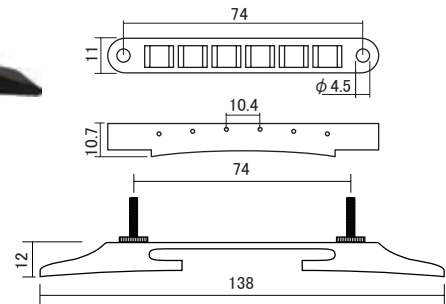

F-2820E / F-2821E

Item#	Description
F-2820E	Nickel, Ebony base
F-2820	Nickel, Rosewood base
F-2821E	Gold, Ebony base
F-2821	Gold, Rosewood base

Acoustic Guitar Bridges



Martin® type machined bridges with countersunk bridge pin holes.
 Saddle slot : 74mm long x 2.6mm wide
 Bridge pin hole spacing : 54.0mm (10.8mm x 5)

Item#	Wood
F-2801	Rosewood
F-2802	Ebony

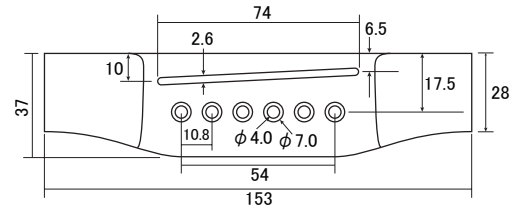

F-2802

Classical Guitar Bridges



Machined bridges w/Purfling. Unfinished.
 String hole spacing : 60.0mm (12.0mm x 5)

Item#	Wood
F-3000X	Rosewood
F-3001X	Ebony



F-3001X

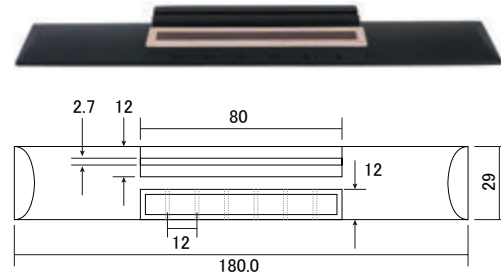

Bridge Pins



All of our bridge pins have a 3-degree taper.
All pins are slotted. Sold as a set of 6.

Plastic Bridge Pins

Item#	Description
F-0001	Cream, No dot
F-0002	Black, No dot
F-0003	White, No dot
F-0006	Cream, Black dot (2mm)
F-0007	Black, White dot (2mm)
F-0008	White, Black dot (2mm)

Item#	Description
F-3608	Black, Abalone dot (3mm)
F-3609	White, Abalone dot (3mm)
F-3610	Cream, Abalone dot (3mm)

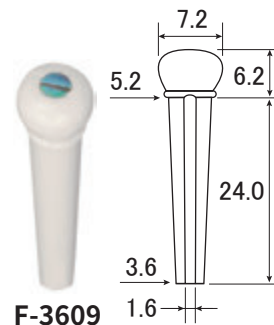

F-3609

Rosewood Bridge Pins

Item#	Description
F-3602	Rosewood, No dot
F-3603	Rosewood, MOP dot (3mm)

Ebony Bridge Pins

Item#	Description
F-3605	Ebony, No dot
F-3606	Ebony, MOP dot (3mm)

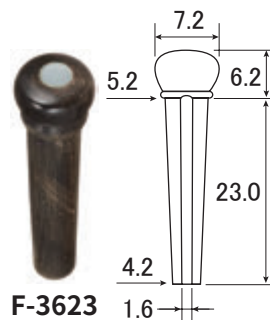

F-3623

Bone Bridge Pins

Item#	Description
F-3620	Cattle bone, No dot
F-3621	Cattle bone, MOP dot (3mm)

Horn Bridge Pins

Item#	Description
F-3622	Buffalo horn, No dot
F-3623	Buffalo horn, MOP dot (3mm)

Brass Bridge Pin

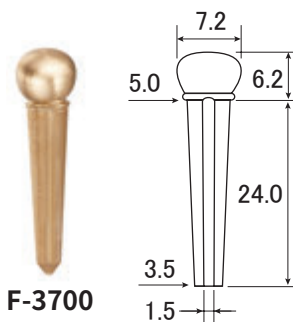

F-3700

Item#	Description
F-3700	Solid brass, No dot

Plastic Bridge Pin/Endpin Assortment



PIN-ASSORT

Item# PIN-ASSORT

Description
Plastic Bridge Pins Black x 36, White x 36, Cream x 36, Black w/dot x 60, White w/dot x 60, Cream w/dot x 60
Endpins Black x 6, White x 6, Cream x 6 Black x 24, White x 24

Tailpieces

Vibrola Tailpieces HOSCO Pack

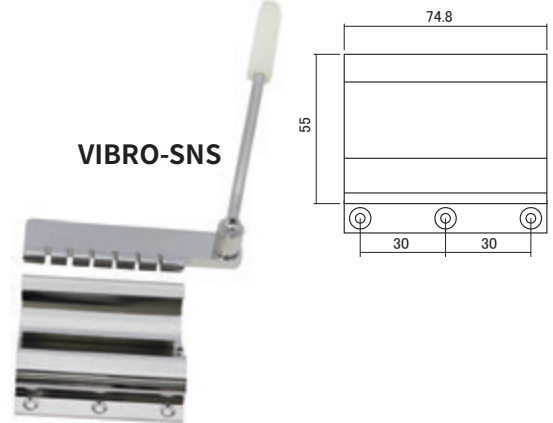
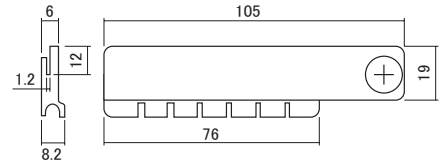
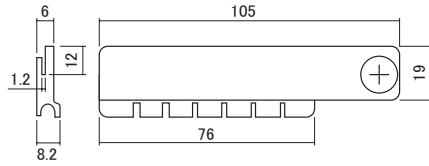

Screws included.

Item#	Description
VIBRO-LNS	Long type, Nickel
VIBRO-SNS	Short type, Nickel

Archtop Guitar Tailpieces HOSCO Pack

Hinged model for archtop guitars.
Screws included.

335 type

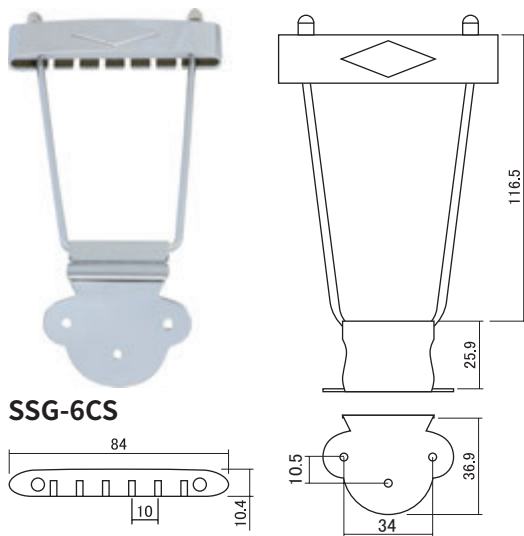

SSG-6CS

Item#	Finish
SSG-6CS	Chrome
SSG-6GS	Gold

Split Trapeze type



TP-EPHCS

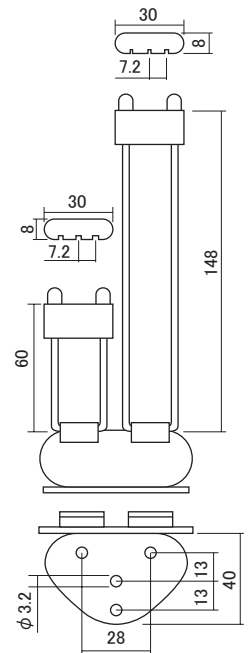

Item#	Finish
TP-EPHCS	Chrome
TP-EPHGS	Gold

Archtop Guitar Tailpieces



175 type Tailpieces

Screws included.

Item#	Finish
TP-175CS	Chrome
TP-175GS	Gold



TP-175CS

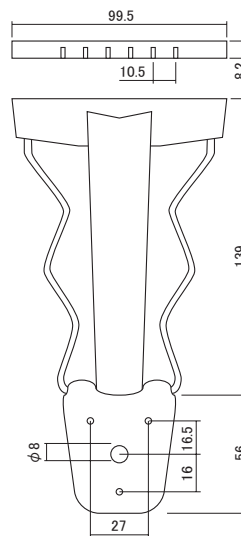

Jazz Guitar Tailpiece



Trapeze for Django guitars with original style plastic insert.
 Both of ball-end and loop-end strings can be used.
 Screws are NOT included.
 Material : Brass

Item#	Description
F-2850	Jazz Guitar Tailpiece, Brass



F-2850

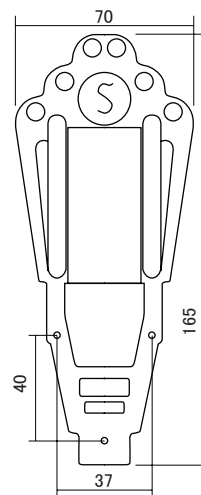

Electric Guitar Tailpieces

FIXER Tailpiece Lock System HOSCO[®] Pack

Just install FIXER onto your guitars and then your guitar sound will be much better!

- The tailpiece will fit a guitar body perfectly by FIXER so that a string vibration will be transmitted to the guitar body very well.
- The guitar sound will be clear and the response will be quick.
- The sustain will be improved and the note will last longer.
- The guitar body will be able to make a bigger sound.

FIXER is sold with HOSCO[®] packaging.

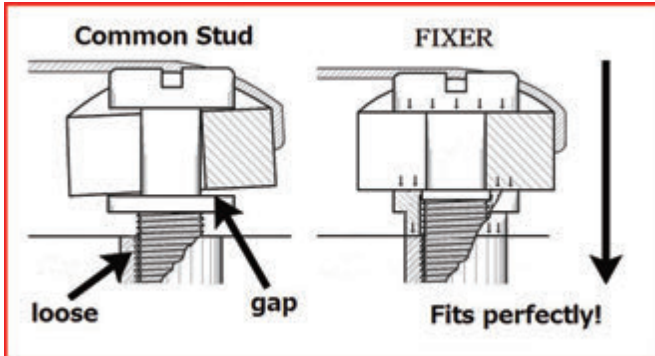

HOW TO USE



A set includes :
 Stud x 2
 Spacer x 6 (2 of each 2.5mm, 4.0mm and 5.5mm)

Material : Steel
 Made in Japan (Utility model registration no. U3114118)

Metric

Item#	Finish
H-FIXC	Chrome
H-FIXN	Nickel
H-FIXG	Gold

Inch

Item#	Finish
H-FIXC-I	Chrome
H-FIXN-I	Nickel
H-FIXG-I	Gold

Item#	Description
H-FIX-ASP	Aluminum spacers only, 2 of each 2.5mm, 4.0mm and 5.5mm



The aluminum spacers make a softer sound like vintage guitars.

Knobs

Control Knobs for Guitars

ST Volume/Tone Knobs HOSCO Pack

Metric knobs are for coarse-knurled pot shafts like Alpha and our CTS metric pots. Inch knobs are for fine-knurled pot shafts like common CTS pots.



KB-240V

KI-240V

KM-240VGL

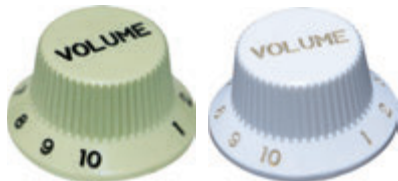

KV-24V

KW-240V

For Volume (Metric size)

Item#	Color
KB-240V	Black
KI-240V	Cream, w/Black letters
KM-240VGL	Mint Green, w/Gold letters
KV-24V	Mint Green, w/Black letters
KW-240V	White



KB-240T

KI-240T

KM-240TGL

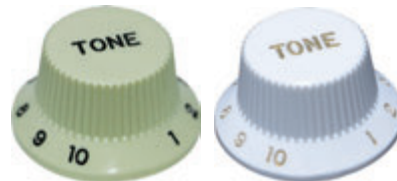

KV-24T

KW-240T

For Tone (Metric size)

Item#	Color
KB-240T	Black
KI-240T	Cream, w/Black letters
KM-240TGL	Mint Green, w/Gold letters
KV-24T	Mint Green, w/Black letters
KW-240T	White

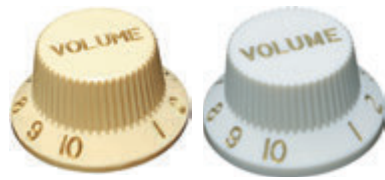

KI-240VI

KP-240VI



KVT-240VI

KRW-240VI

For Volume (Inch size)

Item#	Color
KB-240VI	Black
KI-240VI	Cream, w/Gold letters
KP-240VI	Parchment White
KVT-240VI	Vintage (*This is not relic.)
KW-240VI	White
KRW-240VI	Relic White

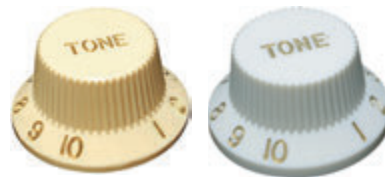

KI-240TI

KP-240TI

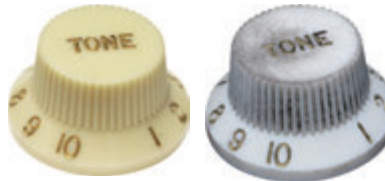

KVT-240TI

KRW-240TI

For Tone (Inch size)

Item#	Color
KB-240TI	Black
KI-240TI	Cream, w/Gold letters
KP-240TI	Parchment White
KVT-240TI	Vintage (*This is not relic.)
KW-240TI	White
KRW-240TI	Relic White

Master Relic Collection Control Knob Sets



MRC-STKN50W-SET

Round edges with buffed surface on knobs with dirt buildup on the sides and darkish brown fonts. Based on White.



MRC-STKN60W-SET

Dirt buildup on the sides of knobs, finely worn lines on surface and oxidized green fonts. Based on Parchment White.

Item#	Description
MRC-STKN50W-SET	50s, Relic White, 3/SET (Vx1/Tx2)
MRC-STKN60W-SET	60s, Relic Parchment White, 3/SET (Vx1/Tx2)

Speed Knobs



Metric knobs are for coarse-knurled pot shafts like Alpha and our CTS metric pots. Inch knobs are for fine-knurled pot shafts like common CTS pots.



KA-110

KB-110

KG-110

Metric size

Item#	Color
KA-110	Amber
KB-110	Black
KG-110	Gold

Inch size

Item#	Color
KA-110I	Amber
KB-110I	Black
KG-110I	Gold



SKA-110I

SKB-110I

SKG-110I

Inch size w/Embossed numbers

Item#	Color
SKA-110I	Amber
SKB-110I	Black
SKG-110I	Gold

SKB-110I/R	Relic Black
SKG-110I/R	Relic Gold



Embossed numbers

*Embossed numbers look like vintage.

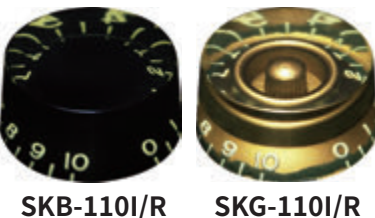

SKB-110I/R

SKG-110I/R

Bell Knobs

**HOSCO®
Pack**



KA-160

KB-160

KG-160



SKA-160I

SKB-160I

SKG-160I



SKB-160I/R

SKG-160I/R

Metric size

Item#	Color
KA-160	Amber
KB-160	Black
KG-160	Gold

Inch size

Item#	Color
KA-160I	Amber
KB-160I	Black
KG-160I	Gold

Inch size w/Embossed Numbers

Item#	Color
SKA-160I	Amber
SKB-160I	Black
SKG-160I	Gold
SKB-160I/R	Relic Black
SKG-160I/R	Relic Gold



Embossed numbers

*Embossed numbers look like vintage.

Large Hat Knobs w/Metal Plates

**HOSCO®
Pack**



KG-260V

KS-260VI

KW-260V

For Volume (Metric size)

Item#	Description
KS-260V	Black, w/Silver plate
KG-260V	Black, w/Gold plate
KW-260V	White, w/Silver plate

For Volume (Inch size)

KS-260VI	Black, w/Silver plate
KG-260VI	Black, w/Gold plate
KW-260VI	White, w/Silver plate



KG-260T

KS-260TI

KW-260T

For Tone (Metric size)

Item#	Description
KS-260T	Black, w/Silver plate
KG-260T	Black, w/Gold plate
KW-260T	White, w/Silver plate

For Tone (Inch size)

KS-260TI	Black, w/Silver plate
KG-260TI	Black, w/Gold plate
KW-260TI	White, w/Silver plate

Hat Knobs w/Metal Plates



Metric knobs are for coarse-knurled pot shafts like Alpha and our CTS metric pots.
 Inch knobs are for fine-knurled pot shafts like common CTS pots.



KB-130V



KB-130VG



KG-130VI



KG-130VSI



KG-130VSI/R

For Volume (Metric size)

Item#	Description
KB-130V	Black, w/Silver plate
KB-130VG	Black, w/Gold plate
KG-130V	Gold, w/Gold plate
KG-130VS	Gold, w/Silver plate
KG-130VS/R	Gold, w/Silver plate, Relic

For Volume (Inch size)

KB-130VI	Black, w/Silver plate
KB-130VGI	Black, w/Gold plate
KG-130VI	Gold, w/Gold plate
KG-130VSI	Gold, w/Silver plate
KG-130VSI/R	Gold, w/Silver plate, Relic



KB-130T



KB-130TG



KG-130TI



KG-130TSI



KG-130TSI/R

For Tone (Metric size)

Item#	Description
KB-130T	Black, w/Silver plate
KB-130TG	Black, w/Gold plate
KG-130T	Gold, w/Gold plate
KG-130TS	Gold, w/Silver plate
KG-130TS/R	Gold, w/Silver plate, Relic

For Tone (Inch size)

KB-130TI	Black, w/Silver plate
KB-130TGI	Black, w/Gold plate
KG-130TI	Gold, w/Gold plate
KG-130TSI	Gold, w/Silver plate
KG-130TSI/R	Gold, w/Silver plate, Relic

Metal Knobs



In addition to our regular knobs, we offer you several different metal knobs to decorate your instruments. Our metal knobs are sized for either a 6mm (15/64") or 6.35mm (1/4") shaft. Our most recommendable knobs are MK-19FF and MK-19D. Each metal knob comes with a set screw.

* = Color

MK*-19FF <While stock lasts>

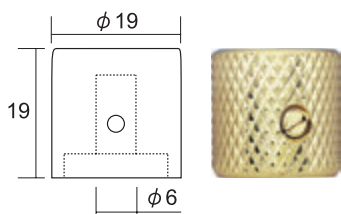

Gold

MK-19F* <While stock lasts>

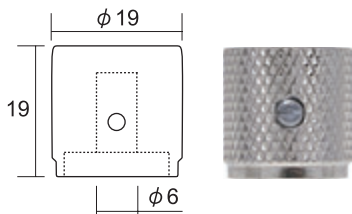

Chrome

MK*-19D

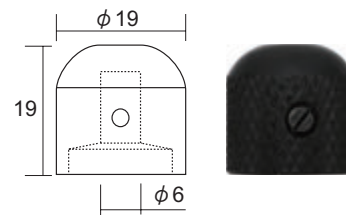

Black Chrome Gold

HK-MKF*

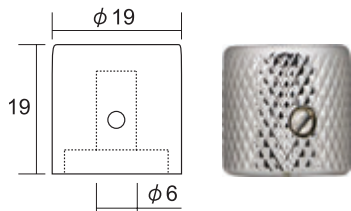

Black Chrome Gold

MK-19F*I

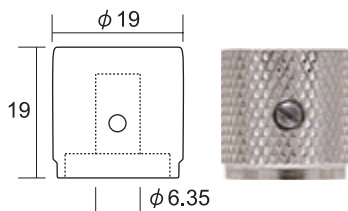

Chrome Nickel

MK*-18I

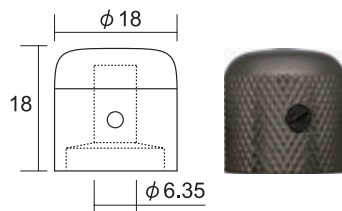

Black Chrome Cosmo Black Gold Aged Chrome

* = Color

	For shaft (Metric or Inch)	Height	Dia.	Finish	Set screw	Head shape
MK*-19FF	Metric / 6mm (15/64")	19mm	19mm	B/C/G	Yes	Flat
MK-19F*	Metric / 6mm (15/64")	19mm	19mm	C/N	Yes	Flat
MK*-19D	Metric / 6mm (15/64")	19mm	19mm	B/C/G	Yes	Dome
HK-MKF*	Metric / 6mm (15/64")	19mm	19mm	B/C/G	Yes	Flat
MK-19F*I	Inch / 6.35mm (1/4")	19mm	19mm	C/N	Yes	Flat
MK*-18I	Inch / 6.35mm (1/4")	18mm	18mm	B/C/CK/AC/G	Yes	Dome

Metric size

Item#	Description	Item#	Description
MKG-19FF	Flat, Gold	HK-MKFB	Flat, Black
MK-19FC	Flat, Chrome	HK-MKFC	Flat, Chrome
MKB-19D	Dome, Black	HK-MKFG	Flat, Gold
MKC-19D	Dome, Chrome		
MKG-19D	Dome, Gold		

Inch size

Item#	Description
MK-19FCI	Flat, Chrome
MK-19FNI	Flat, Nickel
MKB-18I	Dome, Black
MKC-18I	Dome, Chrome
MKCK-18I	Dome, Cosmo Black
NEW MKAC-18I	Dome, Aged Chrome
MKG-18I	Dome, Gold

Control Knobs for Basses



JB type Control Knobs

The KJB-500L can be used for MG as well.
The KJB-500L and KJB-500S are made of bakelite.



KB-140L

KB-140S



KJB-500L

KJB-500L/R

KJB-500S

KJB-500S/R

Item#	Description
KB-140L	Black, Metric, Large
KB-140S	Black, Metric, Small

Item#	Description
KJB-500L*	Black, Round contour, w/set screw, Large
KJB-500S*	Black, Round contour, w/set screw, Small
KJB-500L/R*	Relic Black, Round contour, w/set screw, Large
KJB-500S/R*	Relic Black, Round contour, w/set screw, Small

*marked knobs can be used for both inch and metric sizes.

Rickenbacker® type Knobs



*Metric size only.



KB-170BV

KB-170TV

KB-170BT

KB-170TT

KB-170S

Item#	Description
KB-170BV	Bass Volume
KB-170TV	Treble Volume

Item#	Description
KB-170BT	Bass Tone
KB-170TT	Treble Tone

Item#	Description
KB-170S	Other control

Toggle Switch Knobs



Choose Metric or Inch depending on the switches.



TA-340

TB-340

TI-340

TW-340

TBS-340

TCH-340

TGL-340

Metric size

Item#	Color
TA-340	Amber
TB-340	Black
TI-340	Cream
TW-340	White

TBS-340	Brass, Unplated
TCH-340	Brass, Chrome
TGL-340	Brass, Gold

Inch size

Item#	Color
TA-340I	Amber
TB-340I	Black
TI-340I	Cream
TW-340I	White

TBS-340I	Brass, Unplated
TCH-340I	Brass, Chrome
TGL-340I	Brass, Gold

Lever Switch Knobs



Choose Metric or Inch depending on the switches.

TL type

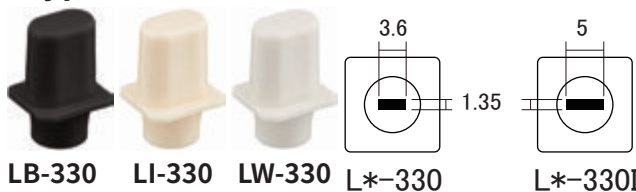

LB-330 LI-330 LW-330 L*-330 L*-330I

Metric size

Item#	Color
LB-330	Black
LI-330	Cream
LW-330	White

Inch size

Item#	Color
LB-330I	Black
LI-330I	Cream
LW-330I	White

Old TL type

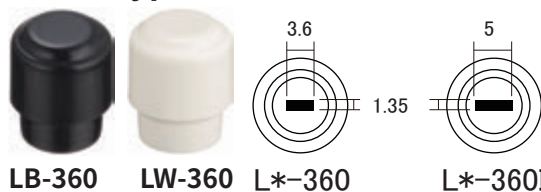

LB-360 LW-360 L*-360 L*-360I

Metric size

Item#	Color
LB-360	Black
LW-360	White

Inch size

Item#	Color
LB-360I	Black
LW-360I	White

ST type



LB-390 LI-390 LM-390 LP-390

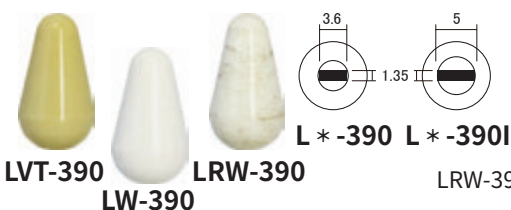

LVT-390 LW-390 LRW-390

Metric size

Item#	Color
LB-390	Black
LI-390	Cream
LM-390	Mint
LP-390	Parchment White
LVT-390	Vintage *This is not relic.
LW-390	White
LRW-390	Relic White

Inch size

Item#	Color
LB-390I	Black
LI-390I	Cream
LM-390I	Mint
LP-390I	Parchment White
LVT-390I	Vintage *This is not relic.
LW-390I	White
LRW-390I	Relic White

LRW-390 is recommended to use with GOTOH® RELIC Series or other aged parts.

Arm Knobs



AB-400 AW-400 ARW-400

5mm diameter hole.

Item#	Color
AB-400	Black
AW-400	White
ARW-400	Relic White

Arm/Switch Knob Set



Arm knob : 5mm dia.
Switch knob : Inch



MRC-STASW-SET

Item#	Color
MRC-STASW-SET	Relic Parchment White

Other Control Knobs



*Metric size only.



KB-SB KB-150 KG-150

Item#	Description
KB-SB	SB type, Black
KB-150	Point knob, Black
KG-150	Point knob, Gold



KBS-200



KV-520

Item#	Description
KBS-200	Amp knob, w/set screw, Black
KV-520	Violin bass knob, w/set screw

Knob Assortment Sets

Selected knobs with stylish container. Component knobs are also available individually.

Gibson® type Knob Assortment, Inch-size



KNB-ASSORT/G1

Speed knobs (SK-110I) Amber x8, Black x8, Gold x8
Hat knobs (SK-160I) Amber x8, Black x8, Gold x8
Black Hat knobs w/Metal plate (KB-130I) Volume (Plate : Silver x2, Gold x2) Tone (Plate : Silver x2, Gold x2)
Gold Hat knobs w/Metal plate (KG-130I) Volume (Plate : Silver x2, Gold x2) Tone (Plate : Silver x2, Gold x2)
Toggle switch knobs (T-340I) Amber x5, Black x5, Cream x5

*All the control knobs have "Embossed numbers" on them. (G1 only)

Gibson® type Knob Assortment, Metric-size



KNB-ASSORT/G2

Speed knobs (K-110) Amber x8, Black x8, Gold x8
Hat knobs (K-160) Amber x8, Black x8, Gold x8
Black Hat knobs w/Metal plate (KB-130) Volume (Plate : Silver x2, Gold x2) Tone (Plate : Silver x2, Gold x2)
Gold Hat knobs w/Metal plate (KG-130) Volume (Plate : Silver x2, Gold x2) Tone (Plate : Silver x2, Gold x2)
Toggle switch knobs (T-340) Amber x5, Black x5, Cream x5

Fender® type Knob Assortment



KNB-ASSORT/F

ST Volume knobs (K-240VI) Black x4, Parchment wht x4, White x4
ST Tone knobs (K-240TI) Black x8, Parchment wht x8, White x8
JB control knobs (KJB-500) Large x4, Small x2
ST lever switch knobs in Inch (L-390I) Black x4, Parchment wht x4, White x4
ST lever switch knobs in Metric (L-390) Black x4, Parchment wht x4, White x4
TL Barrel switch knobs in Inch (L-360I) Black x2, White x2
TL Barrel switch knobs in Metric (L-360) Black x2, White x2
ST tremolo arm knobs (A-400) Black x2, Parchment wht x2, White x2

Item#	Description
KNB-ASSORT/G1	Gibson® type knob assortment, Inch-size
KNB-ASSORT/G2	Gibson® type knob assortment, Metric-size
KNB-ASSORT/F	Fender® type knob assortment

Bodies

Guitar Bodies

*All the guitar bodies come with an individual box.

ST type Bodies (SSS)

Routed by NC, Unsanded or Sanded



Unsanded

Item#	Wood
BD-08ST	Alder, 2-piece
BD-08STN	Alder, 2-piece for Hardtail *Undrilled for bridge
BD-09ST	Alder, 3-piece
BD-09STN	Alder, 3-piece for Hardtail *Undrilled for bridge
BD-01ST	Mahogany, 1-piece
BD-02ST	Mahogany, 2-piece
BD-03ST	Mahogany, 3-piece
TBD-14ST	Swamp ash, 2-piece
TBD-15ST	Swamp ash, 3-piece
BD-18ST	White ash, 2-piece

Sanded

Item#	Wood
HBD-112	Alder, 2-piece
HBD-112N	Alder, 2-piece for Hardtail *Undrilled for bridge
HBD-11	Alder, 3-piece
HBD-16	Alder, 3-piece for Hardtail *Undrilled for bridge
HBD-111M	Mahogany, 1-piece
HBD-112M	Mahogany, 2-piece
HBD-113M	Mahogany, 3-piece
TBD-14ST-SD	Swamp ash, 2-piece
TBD-15ST-SD	Swamp ash, 3-piece
HBD-112W	White ash, 2-piece

ST type Bodies (HSS)

Unsanded

Item#	Wood
TBD-08ST3	Alder, 2-piece
TBD-09ST3	Alder, 3-piece

Sanded

Item#	Wood
TBD-08ST3-SD	Alder, 2-piece
TBD-09ST3-SD	Alder, 3-piece



Vintage ST type Bodies ('50 style)

Unsanded

Item#	Wood
TVD-08ST	Alder, 2-piece
TVD-09ST	Alder, 3-piece
TVD-14ST	Swamp ash, 2-piece
TVD-15ST	Swamp ash, 3-piece

TVD



Sanded

Item#	Wood
TVD-08ST-SD	Alder, 2-piece
TVD-09ST-SD	Alder, 3-piece
TVD-14ST-SD	Swamp ash, 2-piece
TVD-15ST-SD	Swamp ash, 3-piece



Vintage style control cavity

*All the guitar bodies come with an individual box.

TL type Bodies

Routed by NC, Unsanded or Sanded



Unsanded

Item#	Wood
BD-08TC	Alder, 2-piece
BD-09TC	Alder, 3-piece
BD-01TC	Mahogany, 1-piece
BD-02TC	Mahogany, 2-piece
BD-03TC	Mahogany, 3-piece
TBD-14TC	Swamp ash, 2-piece
TBD-15TC	Swamp ash, 3-piece
BD-18TC	White ash, 2-piece



Sanded

Item#	Wood
HBD-212	Alder, 2-piece
HBD-21	Alder, 3-piece
HBD-211M	Mahogany, 1-piece
HBD-212M	Mahogany, 2-piece
HBD-213M	Mahogany, 3-piece
TBD-14TC-SD	Swamp ash, 2-piece
TBD-15TC-SD	Swamp ash, 3-piece
HBD-212W	White ash, 2-piece

Vintage TL type Bodies ('62 style)

Unsanded

Item#	Wood
TVD-08TC	Alder, 2-piece
TVD-09TC	Alder, 3-piece
TVD-14TC	Swamp ash, 2-piece
TVD-15TC	Swamp ash, 3-piece

Sanded

Item#	Wood
TVD-08TC-SD	Alder, 2-piece
TVD-09TC-SD	Alder, 3-piece
TVD-14TC-SD	Swamp ash, 2-piece
TVD-15TC-SD	Swamp ash, 3-piece



TVD



with channel slot

*All the guitar bodies come with an individual box.

TL Thinline type Bodies

Unsanded

Item#	Wood
TBD-08TT	Alder, 2-piece
TBD-09TT	Alder, 3-piece
TBD-02TT	Mahogany, 2-piece
TBD-03TT	Mahogany, 3-piece
TBD-14TT	Swamp ash, 2-piece
TBD-15TT	Swamp ash, 3-piece

Sanded

Item#	Wood
TBD-08TT-SD	Alder, 2-piece
TBD-09TT-SD	Alder, 3-piece
TBD-02TT-SD	Mahogany, 2-piece
TBD-03TT-SD	Mahogany, 3-piece
TBD-14TT-SD	Swamp ash, 2-piece
TBD-15TT-SD	Swamp ash, 3-piece



TBD-03TT-SD

'72 TL Thinline type Bodies

Unsanded

Item#	Wood
NEW TBD-08TN	Alder, 2-piece

Sanded

Item#	Wood
NEW TBD-08TN-SD	Alder, 2-piece



TBD-08TN-SD

TL Custom type Bodies

Unsanded

Item#	Wood
TBD-08TD	Alder, 2-piece
TBD-09TD	Alder, 3-piece
TBD-14TD	Swamp ash, 2-piece
TBD-15TD	Swamp ash, 3-piece

Sanded

Item#	Wood
TBD-08TD-SD	Alder, 2-piece
TBD-09TD-SD	Alder, 3-piece
TBD-14TD-SD	Swamp ash, 2-piece
TBD-15TD-SD	Swamp ash, 3-piece



TBD-09TD-SD

*All the guitar bodies come with an individual box.

TL Deluxe type Bodies

Unsanded

Item#	Wood
TBD-08TX	Alder, 2-piece
TBD-09TX	Alder, 3-piece
TBD-14TX	Swamp ash, 2-piece
TBD-15TX	Swamp ash, 3-piece

Sanded

Item#	Wood
TBD-08TX-SD	Alder, 2-piece
TBD-09TX-SD	Alder, 3-piece
TBD-14TX-SD	Swamp ash, 2-piece
TBD-15TX-SD	Swamp ash, 3-piece



TBD-15TX



TBD-15TX
(Back contoured)

TL type Laminated Bodies w/Bindings

These bodies are already sanded for finishing.

Fancy wood laminated on top & back of 2-piece Alder body with Cream-colored bindings.

Binding size : 6mm wide x 2mm thick

Item#	Veneer	Body
BD-CMP	Curly maple	Alder, 2-piece
BD-BMP	Bird's eye maple	Alder, 2-piece
BD-HKA	Hawaiian koa	Alder, 2-piece



Cream-colored bindings
6mm(W) x 2mm(T)



BD-CMP



BD-BMP



BD-HKA

TL type Bodies w/Bindings

These bodies are already sanded for finishing.

2-piece body with Cream-colored bindings.

Binding size : 6mm wide x 2mm thick

Item#	Wood
BD-02TC-BD	Mahogany, 2-piece
BD-08TC-BD	Alder, 2-piece



BD-02TC-BD



BD-08TC-BD

*All the guitar bodies come with an individual box.

JM type Bodies

Unsanded

Item#	Wood
TJM-15A	Alder, 2-piece
TJM-16A	Alder, 3-piece

Sanded

Item#	Wood
TJM-15A-SD	Alder, 2-piece
TJM-16A-SD	Alder, 3-piece



TJM-16A-SD

JG type Bodies

Unsanded

Item#	Wood
TBD-08JG	Alder, 2-piece
TBD-09JG	Alder, 3-piece

Sanded

Item#	Wood
TBD-08JG-SD	Alder, 2-piece
TBD-09JG-SD	Alder, 3-piece



TBD-09JG

MG type Bodies

Unsanded

Item#	Wood
NEW TBD-08MG	Alder, 2-piece

Sanded

Item#	Wood
NEW TBD-08MG-SD	Alder, 2-piece



TBD-08MG-SD

*All the guitar bodies come with an individual box.

ST/TL type Finished Bodies

3-piece Alder body painted in high gloss (Polyester).

Available colors are listed on Color options below.

PB/JB type finished bodies are made to order. Please consider a longer lead time.



Color options

Code#	Color
2TS	2-Tone Sunburst
3TS	3-Tone Sunburst
BLK	Black
VWH	Vintage White
SFG	Surf Green
SBL	Sonic Blue
CAR	Candy Apple Red
FRD	Fiesta Red

Bass Bodies

PB type Bodies *All the bass bodies come with an individual box.

Unsanded

Item#	Wood
BD-11PB	Alder, 2-piece
BD-12PB	Alder, 3-piece
BD-04PB	Mahogany, 1-piece
BD-05PB	Mahogany, 2-piece
BD-06PB	Mahogany, 3-piece
TBD-16PB	Swamp ash, 2-piece
TBD-17PB	Swamp ash, 3-piece
BD-20PB	White ash, 2-piece



TBD-15PB

Sanded

Item#	Wood
HBD-312	Alder, 2-piece
HBD-31	Alder, 3-piece
HBD-311M	Mahogany, 1-piece
HBD-312M	Mahogany, 2-piece
HBD-313M	Mahogany, 3-piece
TBD-16PB-SD	Swamp ash, 2-piece
TBD-17PB-SD	Swamp ash, 3-piece
HBD-312W	White ash, 2-piece



HBD-31

*All the bass bodies come with an individual box.

OPB type Bodies

Unsanded

Item#	Wood
TBD-11OP	Alder, 2-piece
TBD-12OP	Alder, 3-piece
TBD-16OP	Swamp ash, 2-piece
TBD-17OP	Swamp ash, 3-piece

Sanded

Item#	Wood
TBD-11OP-SD	Alder, 2-piece
TBD-12OP-SD	Alder, 3-piece
TBD-16OP-SD	Swamp ash, 2-piece
TBD-17OP-SD	Swamp ash, 3-piece



TBD-12OP-SD

JB type Bodies



TBD-16JB



HBD-41

Unsanded

Item#	Wood
BD-11JB	Alder, 2-piece
BD-12JB	Alder, 3-piece
BD-04JB	Mahogany, 1-piece
BD-05JB	Mahogany, 2-piece
BD-06JB	Mahogany, 3-piece
TBD-16JB	Swamp ash, 2-piece
BD-20JB	White ash, 2-piece

Sanded

Item#	Wood
HBD-412	Alder, 2-piece
HBD-41	Alder, 3-piece
HBD-411M	Mahogany, 1-piece
HBD-412M	Mahogany, 2-piece
HBD-413M	Mahogany, 3-piece
TBD-16JB-SD	Swamp ash, 2-piece
HBD-412W	White ash, 2-piece

PJB Hybrid Bodies

Unsanded

Item#	Wood
TBD-11PJB	Alder, 2-piece
TBD-12PJB	Alder, 3-piece

Sanded

Item#	Wood
TBD-11PJB-SD	Alder, 2-piece
TBD-12PJB-SD	Alder, 3-piece



TBD-12PJB

Necks

Guitar Necks

Electric Guitar Necks

The shape of headstock is half-paddle, so you can create your original shape as you like.

1-piece maple necks have skunk stripe.

Scale : 648mm / Nut width : 42mm

Jumbo fret crown size : 2.7mm wide x 1.0mm high (SBB213)

Medium-Jumbo fret crown size : 2.62mm wide x 1.17mm high (HF-M3)

Unfinished only.

The half-paddle headstock necks for basses are made to order. (MOQ : 30 pcs each)



HNK-11/22T

Item#	Heel type	Fingerboard	Radius	Fret size	No. of frets	Note
HNK-11/22T	ST	1-piece maple	12" (305mm)	Jumbo	22	
HNK-11/95RT	ST	1-piece maple	9.5" (240mm)	Medium-Jumbo	21	
HNK-11/22TL	ST	1-piece maple	12" (305mm)	Jumbo	22	for Left-handed
HNK-12/22T	ST	Rosewood	12" (305mm)	Jumbo	22	
HNK-12/95RT	ST	Rosewood	9.5" (240mm)	Medium-Jumbo	21	
HNK-12/22TL	ST	Rosewood	12" (305mm)	Jumbo	22	for Left-handed
HNK-21/22T	TL	1-piece maple	12" (305mm)	Jumbo	22	
HNK-21/95RT	TL	1-piece maple	9.5" (240mm)	Medium-Jumbo	21	
HNK-21/22TL	TL	1-piece maple	12" (305mm)	Jumbo	22	for Left-handed
HNK-22/22T	TL	Rosewood	12" (305mm)	Jumbo	22	
HNK-22/95RT	TL	Rosewood	9.5" (240mm)	Medium-Jumbo	21	
HNK-22/22TL	TL	Rosewood	12" (305mm)	Jumbo	22	for Left-handed

Neck Parts

Neck Joint Ferrules HOSCO Pack

Useful for attaching a neck to a solidbody when you don't use a flat neck plate. You need to make counterbore holes. Two sizes are available. Sold individually.



*15mm dia.
*4mm thick

HK-NFL

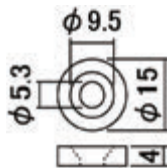

*14mm dia.
*5mm thick

HK-NFS

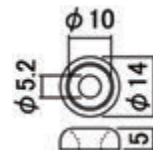

Item#	Description
HK-NFLB	Large, Black
HK-NFLC	Large, Chrome
HK-NFLG	Large, Gold

Item#	Description
HK-NFSB	Small, Black
HK-NFSC	Small, Chrome
HK-NFSG	Small, Gold

Tonewoods

Blank Bodies

These blank bodies should be interesting items for builders who want to build original shaped bodies. We recommend you to carry these blank bodies together with our half-paddle headstock necks. The half-paddle headstock necks for basses are made to order. (MOQ : 30 pcs each)

ST type

Item#	Wood
SG2LA	Swamp ash, 2-piece
SG3LA	Swamp ash, 3-piece

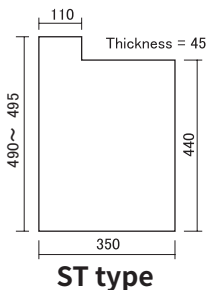

TL type

Item#	Wood
TG2LA	Swamp ash, 2-piece
TG3LA	Swamp ash, 3-piece

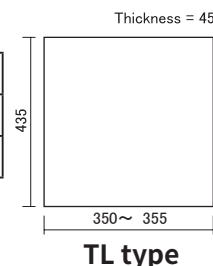

Blank Guitar Bodies



Item#	Wood
BBD-G2A	Alder, 2-piece
BBD-G3A	Alder, 3-piece
BBD-G3M	Mahogany, 3-piece

Blank Bass Bodies

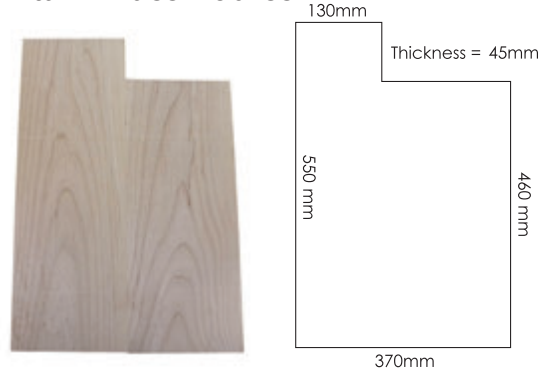

Item#	Wood
BBD-B2A	Alder, 2-piece
BBD-B3A	Alder, 3-piece
BBD-B2M	Mahogany, 2-piece
BBD-B3M	Mahogany, 3-piece

Regarding the blank guitar and bass bodies made of Alder or Mahogany, the square shape cannot be chosen usually because of the factory's reasons. If you prefer the square shape, it will be available with higher prices.

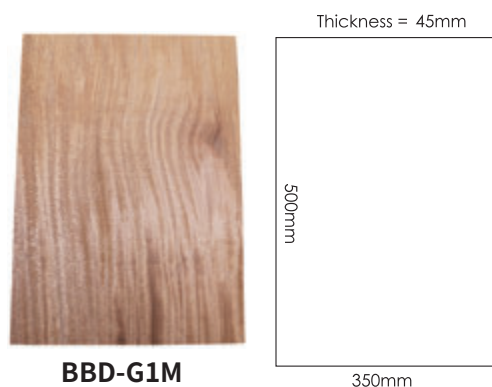

Item#	Wood
BBD-G1M	Mahogany, 1-piece
BBD-G2M	Mahogany, 2-piece

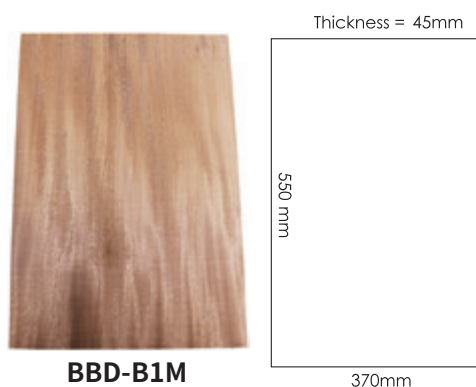

Item#	Wood
BBD-B1M	Mahogany, 1-piece

Blank Necks (for bolt on)

Blank Guitar Necks

(720mm long x 110mm wide x 27mm thick)

Item#	Wood	Headstock	Grade
BNCK-GMA/A	Maple, Flat grain	Flat	A
BNCK-GMA/2A	Maple, Flat grain	Flat	2A

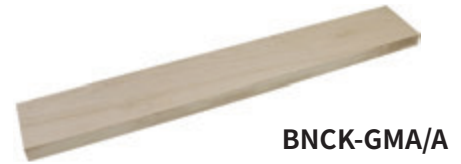

(<220mm long headstock + 520mm long fingerboard> x 63mm wide x 25mm thick)

The following blank necks come with a peghead "Ears" material.

Item#	Wood	Headstock	Grade
BNCK-GMA14/A	Maple, 1-piece	14-degree	A
BNCK-GMA14/2A	Maple, 1-piece	14-degree	2A
BNCK-G3MA14/A	Maple, 3-piece	14-degree	A
BNCK-G3MA14/2A	Maple, 3-piece	14-degree	2A

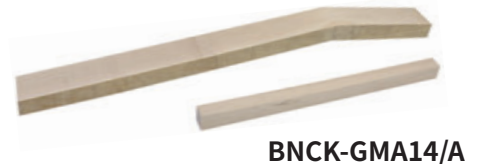

Blank Bass Necks

(920mm long x 130mm wide x 27mm thick)

Item#	Wood	Headstock	Grade
BNCK-BMA/A	Maple, Flat grain	Flat	A
BNCK-BMA/2A	Maple, Flat grain	Flat	2A

(<230mm long headstock + 720mm long fingerboard> x 70mm wide x 25mm thick)

The following blank necks come with a peghead "Ears" material.

Item#	Wood	Headstock	Grade
BNCK-BMA14/A	Maple, 1-piece	14-degree	A
BNCK-BMA14/2A	Maple, 1-piece	14-degree	2A
BNCK-B3MA14/A	Maple, 3-piece	14-degree	A
BNCK-B3MA14/2A	Maple, 3-piece	14-degree	2A

Blank Fingerboards

(700mm long x 60/70mm wide x 8mm thick)

Item#	Wood	Grade
BFG-CM/A	Curly maple	A
BFG-CM/2A	Curly maple	2A
BFG-EB/A	Ebony	A
BFG-EB/2A	Ebony	2A

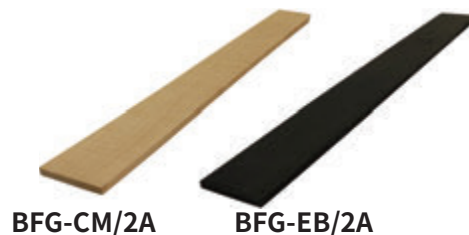

Kerfed Linings

These linings have a veneer on the back side. They are very flexible and easy to handle.

Item#	Size	Set
KL1-SP/MA	740 x 17 x 5mm	Spruce x 2 & Mahogany x 2
KL2-MA	740 x 17 x 6mm	Gaboon(Okoume) x 4
KL3-UK-MA	500 x 10 x 4mm	Mahogany x 2



Fretwire

For the stringed instruments, fretwire greatly affects correct tuning, tone, and playability depending on size, shape, or hardness.

Hosco fretwire is supplied in various style : Packaged fretwire with header, Boxed fretwire, Precut fretwire, and Coiled fretwire. You can choose your needs from our various supply.

Material (Hardness) : Nickel-silver (HV175) *Only U1 and U2 are HV200. / Stainless-steel (HV300)

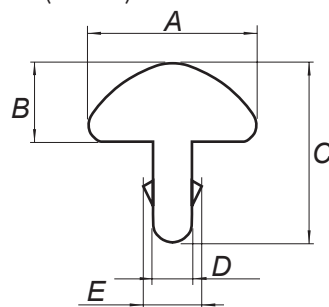

*Reference

HF-S1 is good as replacement frets for Martin® and Yamaha® guitars.

HF-S2 is good as replacement frets for Yamaha® guitars.

HF-M1 is good as replacement frets for Gibson® guitars.

HF-M3 has the same specification as the frets that Fender® uses. (Except width of tang)

Boxed Fretwire

Boxed fretwire packs 400-600 pcs cut in 50cm (19-3/4") long.

Our bulk fretwire is supplied in heavy duty cardboard box of 65mm x 65mm x 670mm (2-1/2"x2-1/2"x26-1/2").

One boxed fretwire is enough for 100-150 guitars or basses, or 150-200 mandolins or banjos.

Material : Nickel silver

Item#	Size	Q'ty per box
HF-S1-600	Small	600
HF-S2-600	Small	600
HF-S3-600	Small	600
HF-M1-500	Medium	500
HF-M2-500	Medium	500
HF-M3-500	Medium-Jumbo	500
HF-J1-400	Jumbo	400
HF-U1-500	Mandolins, Banjos, & Ukes	500
HF-U2-500	Mandolins, Banjos, & Ukes	500



Packed into dampproof storage box

Coiled Fretwire

You can choose the hardness from HV110, 140, 160, 175, or 200.

MOQ : 30 kg

Material : Nickel silver

Item#	Size	Note
FW-202	Jumbo	
FW-214	Medium	
FW-215	Jumbo	Same as HF-J1
FW-216	Jumbo	

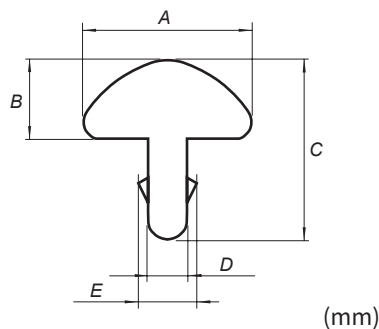

*4 models above are not the same as our packaged fretwire except FW-215.

We can also supply coiled version of the HF series if you want.

	A	B	C	D	E
FW-202	2.65	1.15	2.75	0.5	0.95
FW-214	2.4	1.2	2.8	0.6	0.95
FW-215	2.9	1.3	3.0	0.6	0.95
FW-216	2.8	1.3	3.2	0.6	0.95

Packaged Fretwire



Precut Phosphor bronze Fretwire

Each fret of the following precut Phosphor bronze fretwire is cut based on a standard fretboard (43mm at nut / 53mm at 12th fret) and has an extra length by 0.5mm.

Undercut for bindings : 2.5mm from each end

Radius : 250mm (10") / Sold as a set of 24.

Item#	Size
HFPB-M1-P24	Medium
HFPB-M2-P24	Medium-Jumbo
HFPB-J1-P24	Jumbo

	A	B	C	D	E
NEW HFPB-M1-P24	2.4	1.2	3.0	0.6	0.95
NEW HFPB-M2-P24	2.7	1.0	2.8	0.6	0.95
NEW HFPB-J1-P24	2.9	1.4	3.2	0.6	0.95



Precut Stainless steel Fretwire

Each fret of the following precut stainless-steel fretwire is cut based on a standard fretboard (43mm at nut / 53mm at 12th fret) and has an extra length by 0.5mm.

Undercut for bindings : 2.5mm from each end

Radius : 250mm (10") / Sold as a set of 24.

Item#	Size
HFS-M1-P24	Medium
HFS-M2-P24	Medium-Jumbo
HFS-J1-P24	Jumbo

	A	B	C	D	E
HFS-M1-P24	2.4	1.2	2.8	0.6	0.95
HFS-M2-P24	2.7	1.0	2.8	0.6	0.95
HFS-J1-P24	2.9	1.45	3.2	0.6	0.95



Precut Nickel silver Fretwire

Length : 70mm (2-3/4") / Radius : 300mm (12")

Sold as a set of 24 / MOQ : 10 sets

Non-undercut for bindings

Item#	Size
HF-S1-P24	Small
HF-S2-P24	Small
HF-S3-P24	Small
HF-M1-P24	Medium
HF-M2-P24	Medium
HF-J1-P24	Jumbo

	A	B	C	D	E
HF-S1	2.0	0.9	2.5	0.5	0.8
HF-S2	2.0	1.1	2.6	0.5	0.8
HF-S3	2.1	1.0	2.4	0.5	0.95
HF-M1	2.4	1.4	2.9	0.5	0.8
HF-M2	2.4	1.3	2.8	0.6	0.95
HF-M3	2.62	1.17	2.77	0.53	0.99
HF-J1	2.9	1.3	3.0	0.6	0.95
HF-U1	1.4	0.6	1.9	0.45	0.8
HF-U2	1.1	0.85	2.0	0.45	0.8



HF-J1-P24

Precut Fretwire (OEM)

Precut Fretwire for manufacturers (OEM)

We can supply high quality fretwire at your dimensions. Undercut for bindings are available. Get your fretwire and save your precious time!

MOQ : 100 sets

50cm long Fretwire

One set (30 pcs) can be used for 10 guitars or basses.

Length : 50cm (19-3/4") *Slightly curved / Sold as a set of 30

Material : Nickel silver

Item#	Size
HF-S1	Small
HF-S2	Small
HF-S3	Small

Item#	Size
HF-M1	Medium
HF-M2	Medium
HF-M3	Medium-Jumbo

Item#	Size
HF-J1	Jumbo
HF-U1	Mandolins, Banjos, & Ukles
HF-U2	Mandolins, Banjos, & Ukles

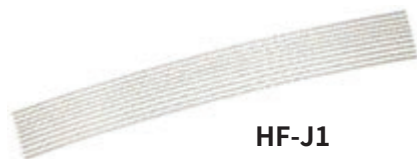

HF-J1

Truss Rods

Two-way Truss Rods

Full titanium and standard steel are now available. Two different lengths for each material. It depends on you which you place more emphasis on Weight or Price. Inquiries for OEM production are greatly appreciated.

Item#	Material	Length	Weight	For
F-2751	Full Titanium	360mm	56g	Acoustic guitars
F-2752	Full Titanium	460mm	72g	Electric & Acoustic guitars
F-2761	Steel	360mm	101g	Acoustic guitars
F-2762	Steel	460mm	126g	Electric & Acoustic guitars
F-2741	Hybrid Titanium/Steel	360mm	76g	Acoustic guitars
F-2742	Hybrid Titanium/Steel	460mm	97g	Electric & Acoustic guitars

Full Titanium

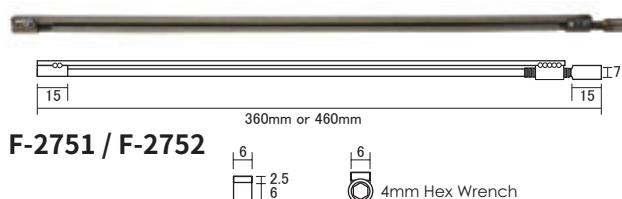

Steel

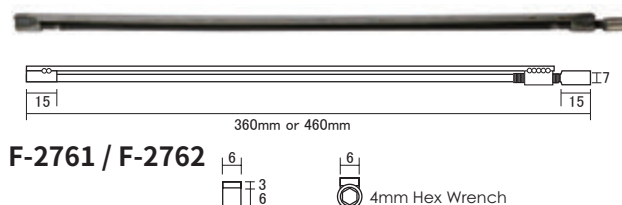

Hybrid Titanium/Steel



Please do not use a glue to fix a two-way truss rod in a channel of the neck because the glue might break the two-way truss rod. If you would like to fill up a tiny gap of the channel, please use a thin viscosity rubber cement.

Martin® type Truss Rods w/Aluminum Channel

These truss rods can be adjusted with 5mm allen wrench. Nut & washer are included. Size of aluminum U-channel : 11mm wide x 9mm deep / Dia. of steel rod : 5mm Total length includes 30mm long adjust nut. Inquiries for OEM production are greatly appreciated.

Item#	Length	Weight	For
F-2714R	361mm	108g	Classical guitars
F-2715R	411mm	121g	Acoustic guitars
F-2716R	446mm	136g	Electric guitars
F-2717R	579mm	175g	Electric basses

*Length above is overall length including a 30mm long truss rod nut.

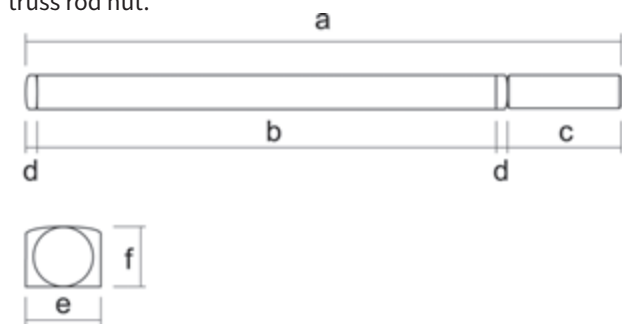

F-2714R



UNIT : mm

	a	b	c	d	e	f
F-2714R	361	325	30	3	11	9.0
F-2715R	411	375	30	3	11	9.0
F-2716R	446	410	30	3	11	9.0
F-2717R	579	543	30	3	11	9.0

Reinforcement Rods

These neck rods prevent necks from twisting. You will experience the very light weight!

Item#	Material	Size	Weight
F-NR450T	Titanium	450 x 6.0 x 2.5mm	30.0g
F-NR550T	Titanium	550 x 6.0 x 2.5mm	36.0g
DM-CF1S	Carbon Fiber	480 x 9.5 x 3.2mm	24.4g
DM-CF1L	Carbon Fiber	630 x 9.5 x 3.2mm	32.0g
DM-CF2S	Carbon Fiber	480 x 6.5 x 5.1mm	25.0g
DM-CF2L	Carbon Fiber	630 x 6.5 x 5.1mm	32.8g

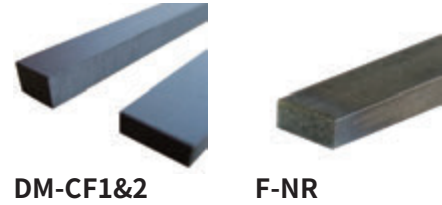

Truss Rod Parts



Truss Rod Nuts

Item#	Description	Wrench	Length	Hole	Note
TRN-10	Bullet, Chrome	4 mm	24 mm	M5	
TRN-11	Cylinder, Nickel	5 mm	25 mm	M5	
TRN-12	Cylinder, Nickel	Slotted	25 mm	M5	
TRN-13	Hex, Brass	8 mm	8 mm	M5	
TRN-14	Hex, Brass	7 mm	10 mm	M5	
TRT-63	Cylinder	N/A	20 mm	M6	3.4mm dia. side holes, While stock lasts

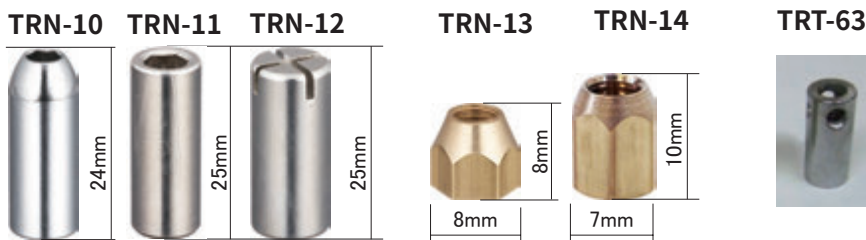

Truss Rod Washers

Item#	Shape	Hole (dia.)
TRW-SQ5	Square	5 mm
TRW-SQ6	Square	6 mm
TRW-RD	Round	5 mm
TRW-HM5	Half-moon	5 mm
TRW-HM6	Half-moon	6 mm

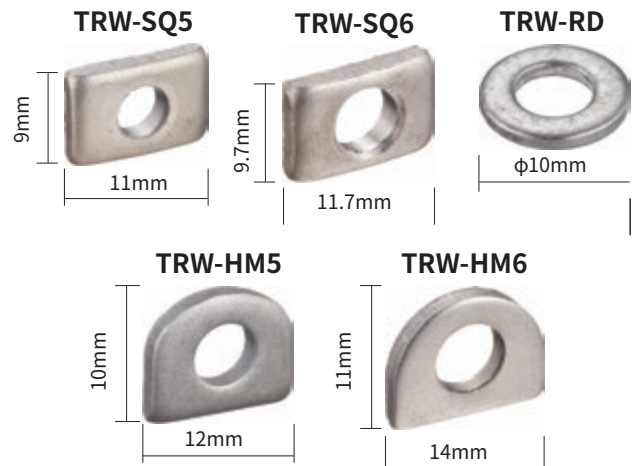

Machine Heads

Guitar Machine Heads



3-on-Plate Machine Heads

Vintage style 3-on-plate machine heads with white buttons. Aged Nickel looks good on old guitars.

Gear ratio = 1:15

Bushings & screws included. (2052NSA : Screws only)



2052ANS

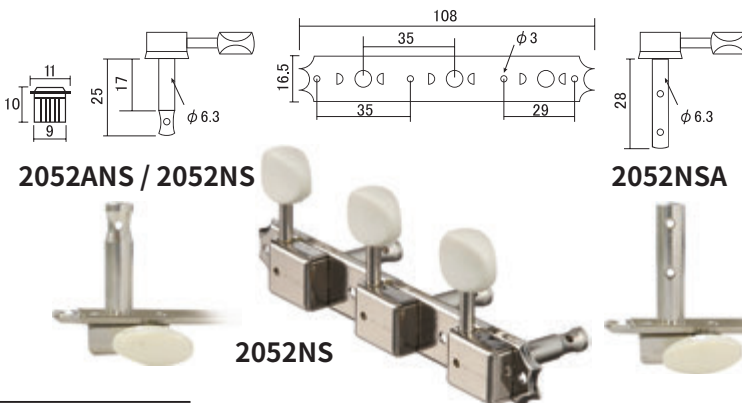

2052ANS / 2052NS

2052NSA

2052NS

Item#	Finish	Note
2052ANS	Aged Nickel	
2052NS	Nickel	
2052NSA	Nickel	For slotted peghead

Vintage style Staggered Machine Heads

GOTOH® vintage style guitar machine heads with "Staggered posts".

Gear ratio = 1:15 / Side : 6 in line (for Right-handed)

Bushings & screws included.

Item#	Finish
21333ANS-STG1	Aged Nickel
21333NS-STG1	Nickel
21333GS-STG1	Gold

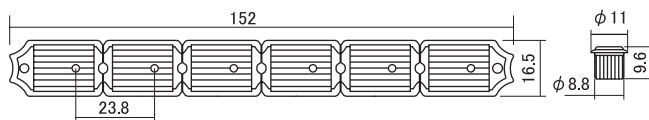

21333ANS-STG1



Staggered posts

GOTOH SG381 Machine Heads w/Ergonomic Ebony Buttons

These SG381 machine heads with the ergonomic ebony buttons are exclusively supplied from Hosco Inc.

Gear ratio = 1:16 / Side : 3 per side / String post : Standard

Threaded nuts, washers, & screws included.

Item#	Finish
07992CS	Chrome
07992GS	Gold



The unique patterned buttons can be chosen while stock lasts. Limited quantity. If you like the patterned buttons, please specify them as "Patterned" in ordering.

Bass Machine Heads



Vintage style Bass Machine Heads

Features cloverleaf keys with long stems and reverse-wind operation like the original ones.
 Bushings & screws included.
 Side : 4 in line (for Right-handed)

Item#	Finish	Gear ratio	Note
3096NS	Nickel	1:26	Riveted plate
3196NS	Nickel	1:28	Torque adjustment

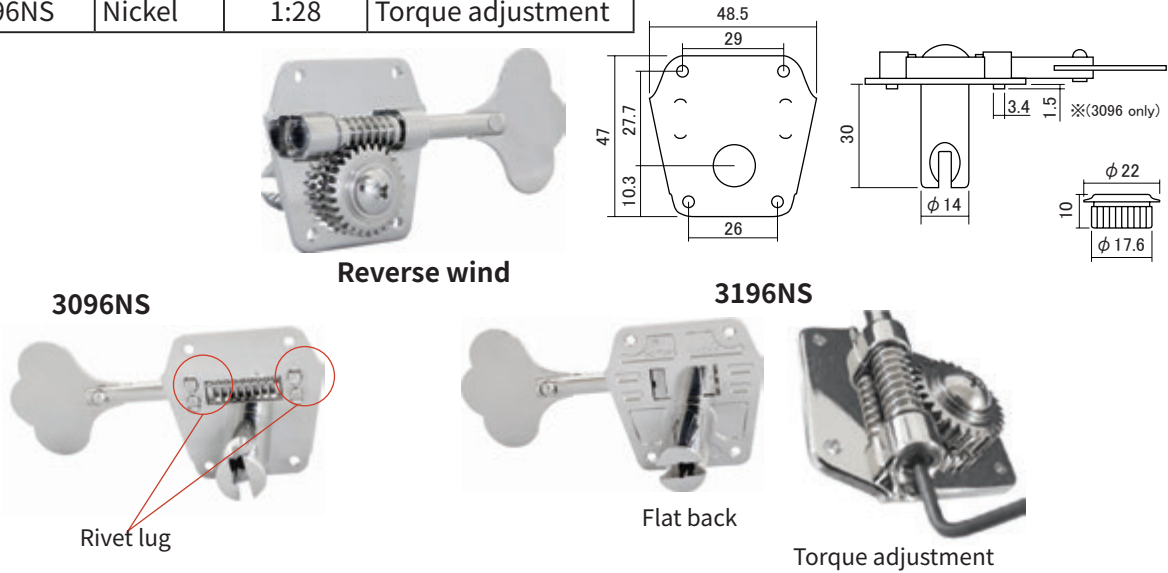

Bushings



Conversion Bushings

For installing GOTOH® SD or SE series machine heads to 10mm diameter peg holes for GOTOH® SG series machine heads. Sold as a set of 6.

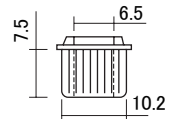

Item#	Shape	Finish
BU-CBHB	Hex	Black
BU-CBHN	Hex	Nickel
BU-CBHG	Hex	Gold
BU-CBB	Round	Black
BU-CBN	Round	Nickel
NEW BU-CBAN	Round	Aged Nickel
BU-CBG	Round	Gold



Push-fit Bushings

The following bushings are good for replacing Fender® original. 9.2mm dia. Sold as a set of 6.

Item#	Shape	Finish
BU-KN92	Round	Nickel
BU-KG92	Round	Gold
BU-KAN92	Round	Aged Nickel

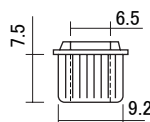

Nuts / Saddles

Blank Bone Nuts



(mm)

Item#	Length	Height	Thickness
F-3300	55	9	6
F-3301*	53	10	4.5-6.0
F-3302*	46.0-43.5	9	6
F-3308	65	10	5
BNK-10	43	6	3.4
BNK-11	39	6	3.4
BNK-12	48	11	4.8
BNK-14	42	6	3.2
BNK-18	48	7	3.5
BNK-19	56	11	5
BNK-20	56	11	6.5
BNK-23	45	8.5	5
BNK-24	45	10	5
BNK-25	50	11	4.5
BNK-29	55	10	6
BNK-8*	42	6	3.2
M-502	37	8	5
BN-7*	43	8	6
BN-9*	44	6	3.2
BN-401*	42.5	6.5	3.1
BN-402*	42.5	6.5	3.1
BN-403*	42.5	6.5	3.1

NOTE

F-3301	Trapezoid
F-3302	Pre-shaped, Angled sides & bottom, 400mm top radius
BNK-8	190mm top radius
BN-7	300mm top radius
BN-9	180mm top & bottom radius
BN-401	180mm top & bottom radius
BN-402	305mm top & bottom radius
BN-403	240mm top & bottom radius

Drawings 100%

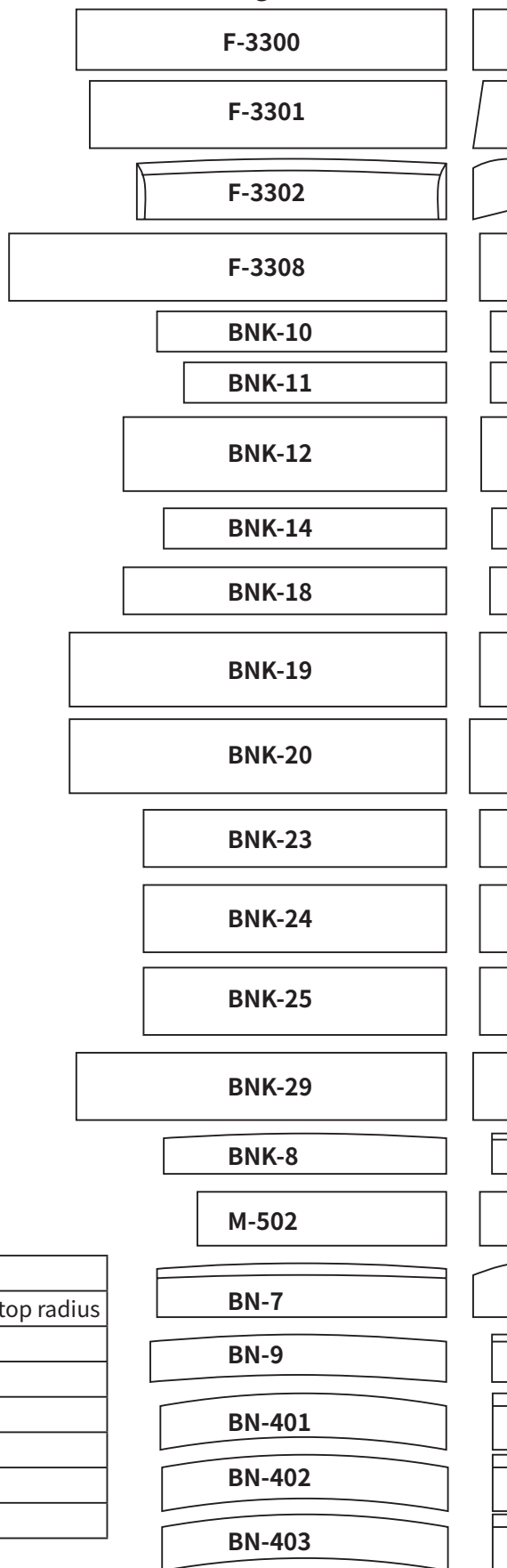

Blank Bone Saddles



(mm)

Item#	Length	Height	Thickness
BNK-21S	108	12	2.8
BNK-30	101.6	12.7	6.6
F-3401	83	8	2.4
F-3402	83	12	2.4
F-3403W	83	12	6
F-3404W	102	12	2.4
F-3405	83	8	3.2
F-3406	83	12	3.2
F-3410	71.5	11	2.3
F-3411	90	11	3.5
BNK-21W	108	12	3.5
BNK-22	75	8	2.4

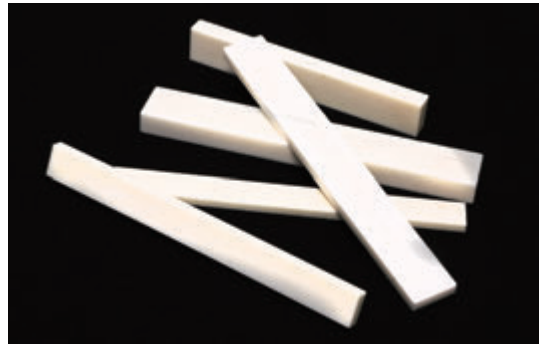

Drawings 100%

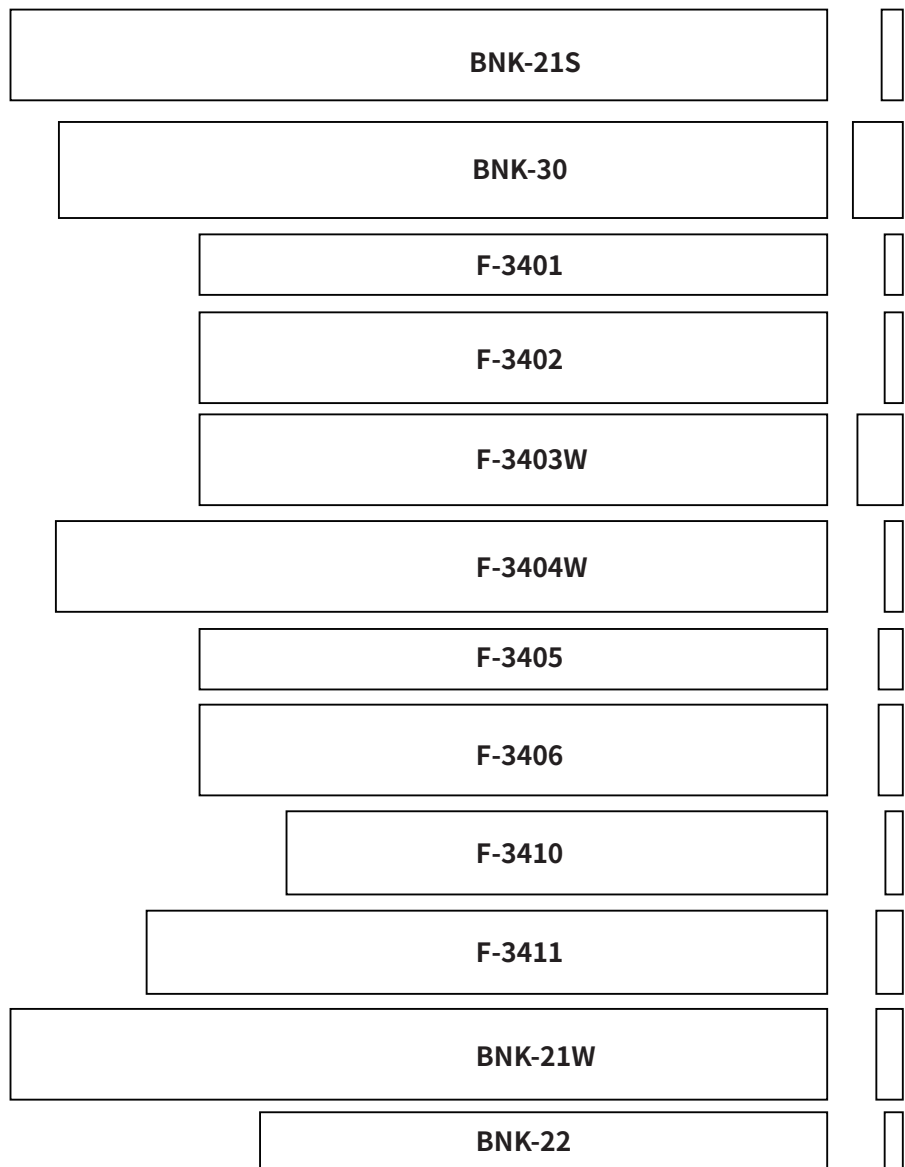

Shaped/Slotted Bone Nuts



These nuts save you a lot of work because each nut is almost shaped and slotted. All you need to do is minor adjustment!
 HSBV series are unbleached and oiled. HSB series are bleached white version. The HSBV series are harder than the HSB series and they look like vintage. Please note that the HSBV series might bleed a little oil from them.

Unbleached / For Acoustic Guitars (mm)

	Item#	Length	Height	Thickness
NEW	HSBV-NM1	43.0 - 44.2	9.0	5.6
NEW	HSBV-NM2	44.0 - 45.0	9.0	5.6

Unbleached / For Electric Guitars (mm)

	Item#	Length	Height	Thickness
NEW	HSBV-NS1	42.86	5.4	3.3
NEW	HSBV-NS1/9.5	42.86	5.4	3.3
NEW	HSBV-NG1	43.4	9.3	4.8



HSB-NM1



HSBV-NS1

Bleached / For Acoustic Guitars (mm)

	Item#	Length	Height	Thickness
	HSB-NM1	43.0 - 44.2	9.0	5.6
	HSB-NM2	44.0 - 45.0	9.0	5.6

Bleached / For Electric Guitars (mm)

	Item#	Length	Height	Thickness
	HSB-NS1	42.86	5.4	3.3
	HSB-NS1/9.5	42.86	5.4	3.3
	HSB-NG1	43.4	9.3	4.8

HSBV-NM1
HSB-NM1
 Martin® type

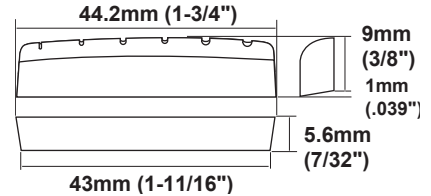

HSBV-NM2
HSB-NM2
 Martin® type

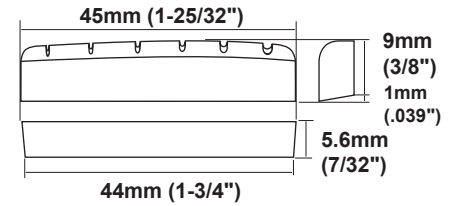

HSBV-NS1
HSB-NS1
 Fender® type
 for 7-1/4" radius

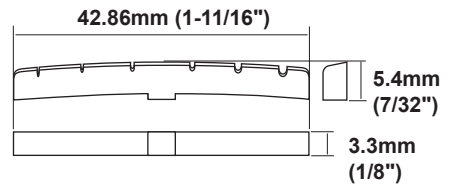

HSBV-NS1 / 9.5
HSB-NS1 / 9.5
 Fender® type
 for 9.5" radius

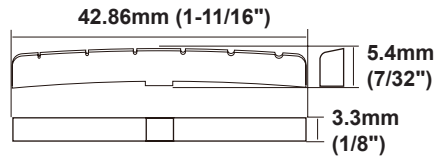

HSBV-NG1
HSB-NG1
 Gibson® type

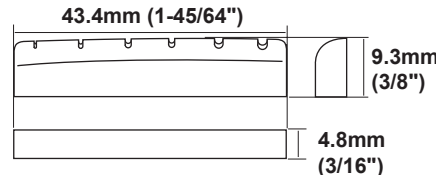

Shaped and Slotted Bone Nut/Saddle (OEM)

We can supply high quality bone nuts and saddles at your dimensions. The bone nuts and saddles are machined accurately by CNC. Excellent quality at reasonable price. Get your bone parts and save a time!
 MOQ : 500 sets (Price varies depending on quantities.)

Shaped Bone Saddles



These saddles save you a lot of work because each saddle is almost shaped. All you need to do is minor adjustment!
 HSBV series are unbleached and oiled. HSB series are bleached white version. The HSBV series are harder than the HSB series and they look like vintage. Please note that the HSBV series might bleed a little oil from them.

Unbleached

(mm)

Item#	Length	Height	Thickness
HSBV-SM1	73.7	10.0	2.8
HSBV-ST1	71.0	9.2	3.1
HSBV-SG1	71.0	11.0	3.3
HSBV-SG2	79.0	9.5	7.0

Bleached

(mm)

Item#	Length	Height	Thickness
HSB-SM1	73.7	10.0	2.8
HSB-ST1	71.0	9.2	3.1
HSB-SG1	71.0	11.0	3.3
HSB-SG2	79.0	9.5	7.0

HSB-ST1



HSBV-SM1
HSB-SM1
 Martin® type

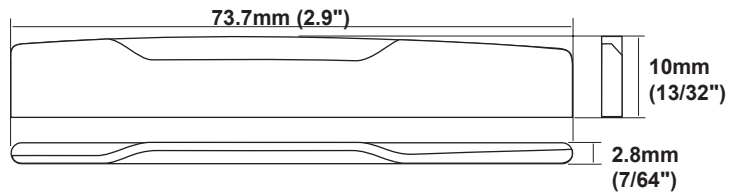

HSBV-ST1
HSB-ST1
 Taylor® type

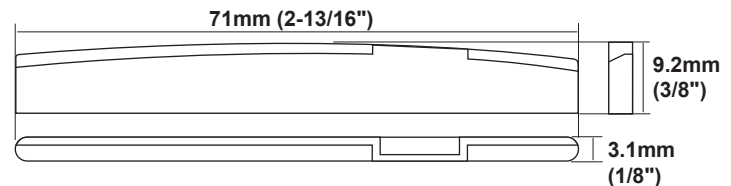

HSBV-SG1
HSB-SG1
 Gibson® type

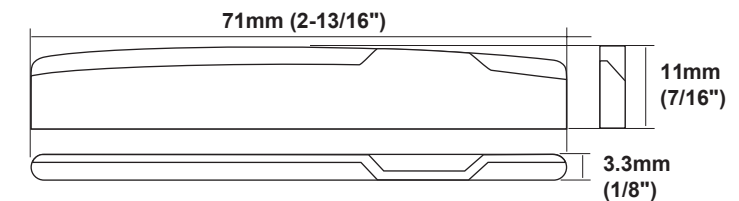

HSBV-SG2



HSBV-SG2
HSB-SG2
 Gibson®
 Adjustable type

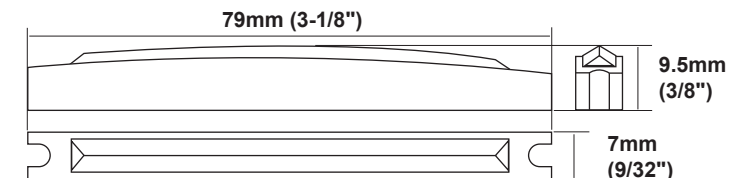

Shaped and Slotted Bone Nut/Saddle (OEM)

We can supply high quality bone nuts and saddles at your dimensions. The bone nuts and saddles are machined accurately by CNC. Excellent quality at reasonable price. Get your bone parts and save a time!
 MOQ : 500 sets (Price varies depending on quantities.)

Visor Nut



Easy installation! Smart looking! And Excellent pitch improvement!
 Visor nut is developed with the same technology as our long seller S.O.S. (Sound Offset Spacer). Each string location is calculated by MTS theory (Patent no. 4383272).
 For most of Fender Strat® (43mm wide nut, 3.2mm nut slot) type guitars
 Fingerboard radius : 9.5"(7.25", 10", and 12")
 Material : Bone / Size : 43mm (width) x 5.0mm (height) x 3.2mm (slot).

Item#	For
VISOR-NS1	ST/TL type (slot-in type)



Sound Offset Spacers



Design based on MTS theory

What is S.O.S.?

S.O.S. improves the intonation at each fret.

Easy installation to your instruments.

Designed and based on MTS theory (Patent no. 4383272) to fit major and standard musical instruments simply.

S.O.S



What is MTS theory?

MTS is an ultimate guitar tuning system based on the laws of physics.

All fretted instruments have fatal problem.

That is, when player pressed the strings at the fret, the string tension is up and tone will be a little bit sharp, though the frets are set on the correct position.

Forerunners knew this problem and they tried to improve the pitch with compensated saddle and or separated saddle.

This kind of approach improves the pitch, but not perfect.

MTS theory succeeded in improving the pitch as correct as possible with Japanese technology.

Inventor, Minehara researched all kind of problems between string tension and pitch gap.

He tested various kind of standard guitar strings in the world and checked these tensions in his labo. Finally, he derived one formula to calculate the corrected (offset) value from string material, guitar scale and string height. The offset value means the adjustment length from the original scale length.

Adjustment length is not only distance between nut and 12th fret but also 12th fret to saddle for each string.

MTS can be applied to majority of the fretted instruments and improve the pitch at each fret.

S.O.S was developed by Hosco with MTS theory (under licensed). As S.O.S. is set at the nut area, it effects to improve the pitch at the low fret area only.

However, most of guitar players feel its improvement well, because low fret area has a big pitch gap.

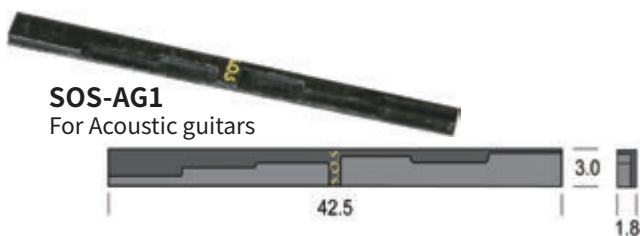

SOS-AG1
For Acoustic guitars

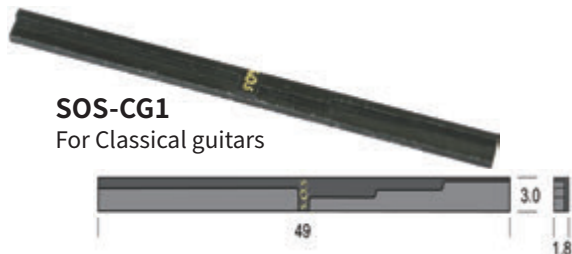

SOS-CG1
For Classical guitars

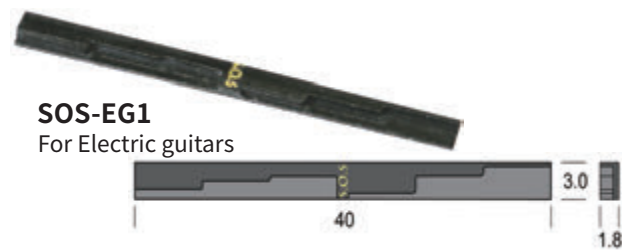

SOS-EG1
For Electric guitars



SOS-US / SOS-UC
For Soprano / For Concert



For Soprano ukuleles
For Concert ukuleles

Item#	Scale	String	S.O.S. Thickness (6th/1st)
SOS-AG1	643-650mm	Bronze	1.3mm/1.2mm
SOS-CG1	640-650mm	Nylon	1.6mm/1.6mm
SOS-EG1	628-650mm	Nickel	1.3mm/1.2mm

Item#	Scale	String	S.O.S. Thickness (4th/1st)
SOS-US1	340-350mm	Nylon	1.4mm(3rd)/1.3mm
SOS-US2	340-350mm	Nylgut	1.4mm(3rd)/1.3mm
SOS-UC1	380-390mm	Nylon	1.4mm(3rd)/1.3mm
SOS-UC2	380-390mm	Nylgut	1.4mm(3rd)/1.3mm



HOW IT WORKS

Brass Nuts



These nuts are machined and made of solid brass.
 Brass nuts can sustain a longer clear tone.
 Our brass nuts are not RoHS compliant.



NTB-01



NTB-02

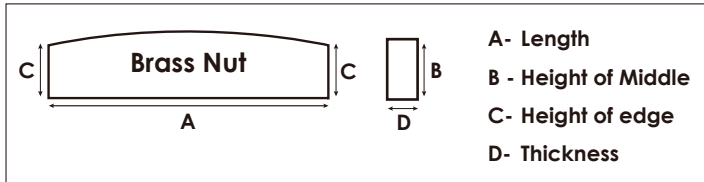

Unslotted Brass Nuts

(mm)

Item#	A	B	C	D
NNB-1	41.0	4.0	4.0	3.0
NNB-2	41.0	5.0	4.0	3.5
NNB-3	41.0	7.0	6.0	4.0
NNB-4	41.0	8.0	6.5	5.0
NNB-5	41.5	10.0	9.0	5.0
NNB-6	41.5	8.0	7.5	5.0
NNB-7	42.0	7.0	6.0	3.5
NNB-8	42.0	8.0	7.5	5.0
NNB-9	43.0	8.0	7.5	5.0
NNB-10	43.0	8.5	7.5	5.0
NNB-11	43.0	8.0	6.5	6.5
NNB-12	43.5	9.5	8.0	5.0
NNB-13	43.5	9.0	8.0	5.0
NNB-14	38.0	6.5	5.5	4.0
NNB-15	46.0	10.0	9.0	5.0

Slotted Brass Nuts

(mm)

Item#	A	B	C	D
NTB-12UP	43.0	5.0	2.5	5.0
NTB-13	40.0	7.5	6.3	5.0
NTB-16	43.0	7.7	6.0	5.0
NTB-17	37.0	4.5	3.5	3.0
NTB-18	*See below.			

NTB-18

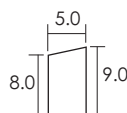

Drawings 100%

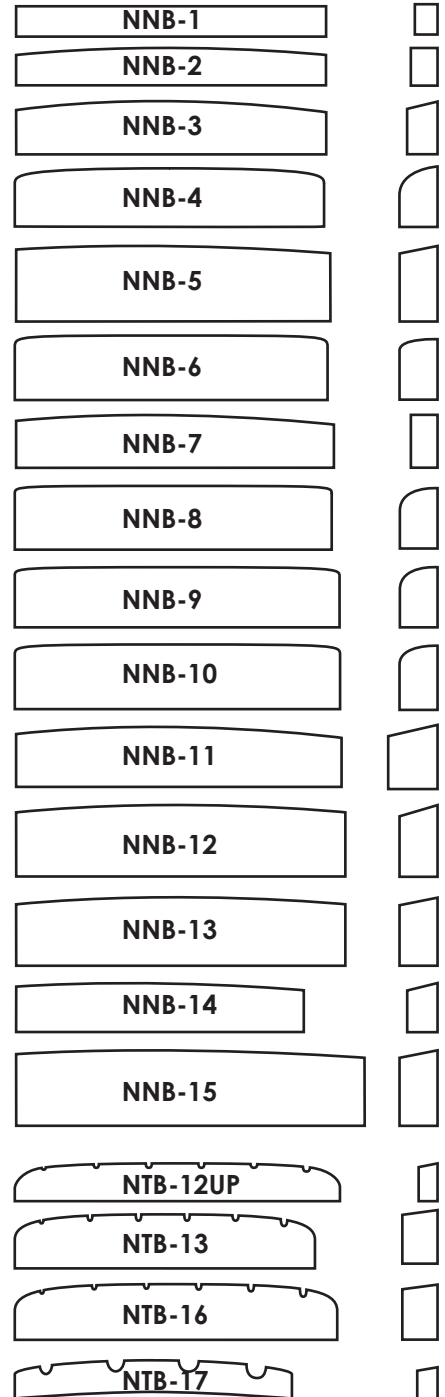

Plastic Nut / Saddle Assortment Sets

Each set comes with a plastic organizer box.

Plastic Nut Assortment



NT-ASSORT

Item#	Description
NT-ASSORT	Classical x 24, Concert Steel x 24, Acoustic x 24, Electric x 12, Elec. Bass x 12, 12-string x 12, Mandolin x 6, Banjo x 6

Plastic Saddle Assortment



SD-ASSORT

Item#	Description
SD-ASSORT	69 x 7.0 x 2.2mm x 24, 82 x 5.5-4.5 x 2.2mm x 24, 82 x 6.5-5.5 x 2.2mm x 24, 82 x 7.5-6.5 x 2.2mm x 24, 82-8.5-7.5 x 2.2mm x 24, 82 x 9.5-8.5 x 2.2mm x 24

Pickup Parts

Mounting Rings for Humbuckers HOSCO Pack

Flat Top / Flat Bottom (Tapered)

Traditional plastic mounting rings for Flat top guitars. Mounting screws are sold separately.
 MR-F Taper : 4.0mm to 5.0mm / MR-R Taper : 10.0mm to 11.7mm

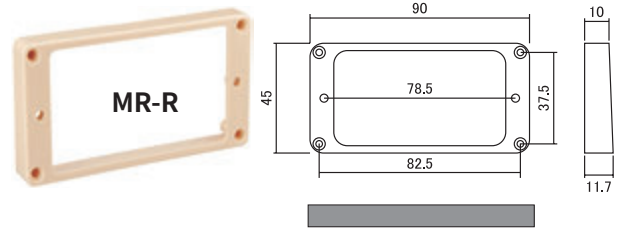
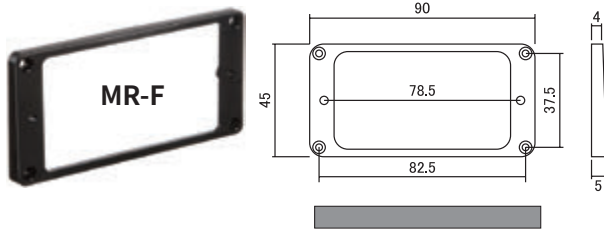

For Neck position

Item#	Color
MR-FB	Black
MR-FI	Cream
MR-FLI	Light Cream
MR-FRLI	Relic Light Cream

For Bridge position

Item#	Color
MR-RB	Black
MR-RI	Cream
MR-RLI	Light Cream
MR-RRLI	Relic Light Cream

Curved Top / Curved Bottom

Traditional plastic mounting rings for Archtop guitars. Mounting screws are sold separately.

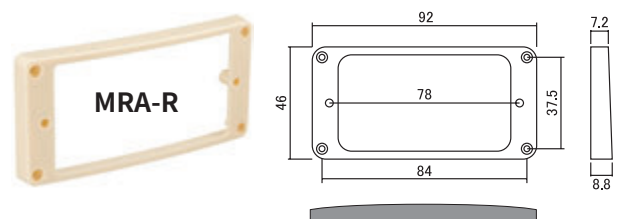
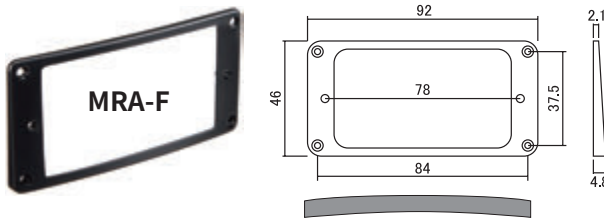

For Neck position

Item#	Color
MRA-FB	Black
MRA-FI	Cream

For Bridge position

Item#	Color
MRA-RB	Black
MRA-RI	Cream

Flat Top / Curved Bottom

Traditional plastic mounting rings for Archtop guitars. Only bottom is curved. Mounting screws are sold separately.

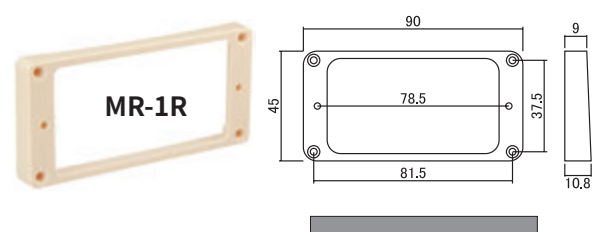
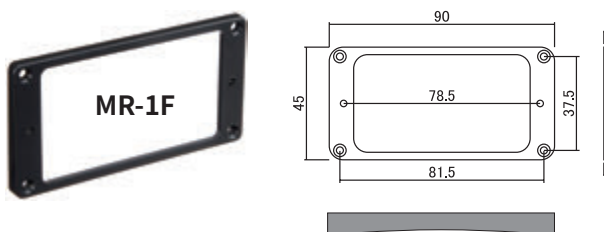

For Neck position

Item#	Color
MR-1FB	Black
MR-1FI	Cream

For Bridge position

Item#	Color
MR-1RB	Black
MR-1RI	Cream

Flat Top / Flat Bottom (Non-tapered) HOSCO[®] Pack

Traditional plastic mounting rings for Flat top guitars. Mounting screws are sold separately.

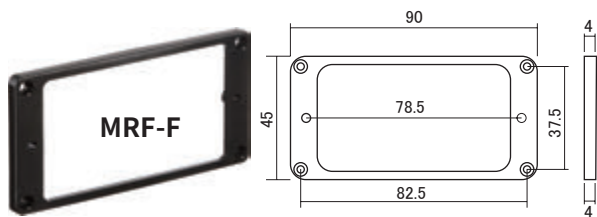

For Neck position

Item#	Color
MRF-FB	Black
MRF-FI	Cream

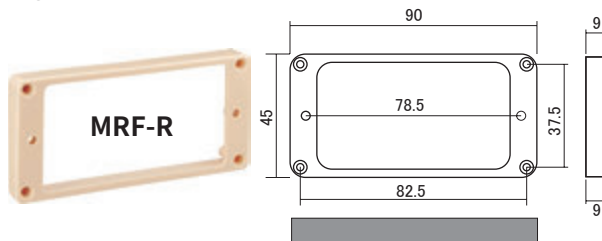

For Bridge position

Item#	Color
MRF-RB	Black
MRF-RI	Cream

Metal Mounting Rings for ST/TL HOSCO[®] Pack

These fit our pickup covers. Mounting screws are included.
Material : Brass

ST type Metal Mounting Rings

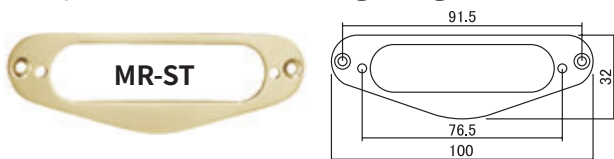

Item#	Finish
MR-STBS	Black
MR-STCS	Chrome
MR-STGS	Gold

TL type Metal Mounting Rings

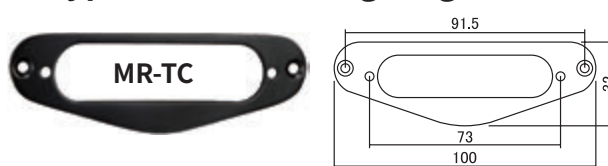

Item#	Finish
MR-TCBS	Black
MR-TCCS	Chrome
MR-TCGS	Gold

Guitar Pickup Covers HOSCO[®] Pack

P-90 type Pickup Covers

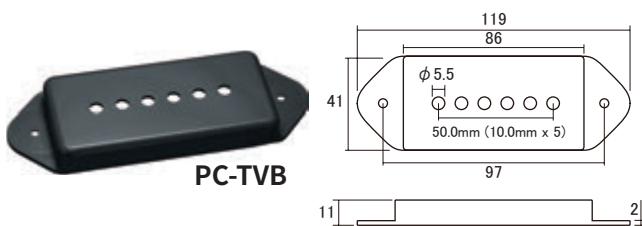

Item#	Description
PC-TVB	Dog-ear type, Black
PC-TVI	Dog-ear type, Cream

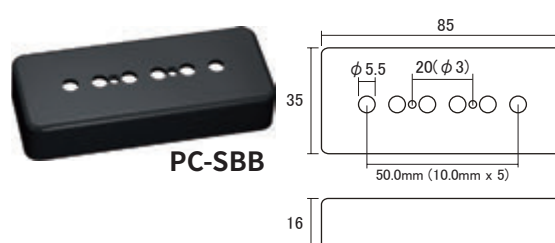

Item#	Description
PC-SBB	Soap-bar type, Black
PC-SBI	Soap-bar type, Cream

ST type Plastic Pickup Covers



PC-2 covers are Matte and OD-ST-C covers are Glossy except OD-ST-CRW (Relic). Polepiece spacing : 52.5mm (10.5mm x 5)

Item#	Color
OD-ST-CB	Black
OD-ST-CW	White
OD-ST-CM	Mint
OD-ST-CI	Cream
OD-ST-CP	Parchment White
OD-ST-CRW	Relic White
NEW OD-ST-CVT	Vintage Cream

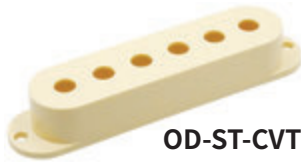

OD-ST-CVT

Item#	Color
PC-2B	Black (Matte)
PC-2W	White (Matte)

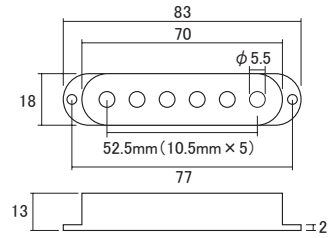

MG type Plastic Pickup Covers

Item#	Color
NEW OD-MG-CB	Black
NEW OD-MG-CW	White
NEW OD-MG-CVT	Vintage Cream



OD-MG-CB

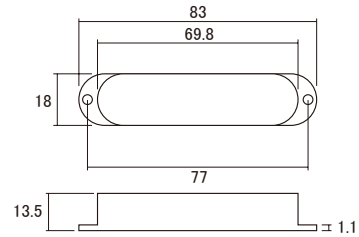

Master Relic Collection ST type Pickup Cover Sets

Polepiece spacing : 52.5mm (10.5mm x 5)



MRC-STPC50W-SET

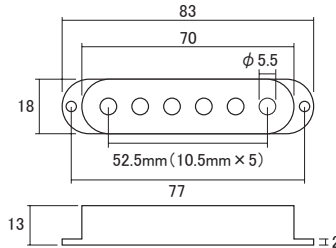

MRC-STPC60W-SET

Item#	Description
MRC-STPC50W-SET	50s, Relic White, 3/SET

Item#	Description
MRC-STPC60W-SET	60s, Relic Parchment WH, 3/SET

TL type Metal Pickup Covers



OD-TE-CN

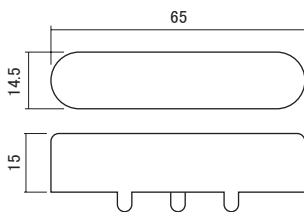

Item#	Finish
OD-TE-CG	Gold
OD-TE-CN	Nickel

Master Relic Collection TL type Pickup Cover

Worn surface with faint shadow marks left from the strings. All tastefully done with no exaggeration.



MRC-TLPCN

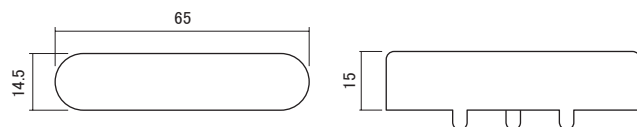

Item#	Description
MRC-TLPCN	Neck position, Aged Nickel

Humbucker Pickup Covers



PC-HX

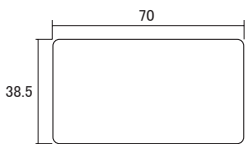

PUC-98

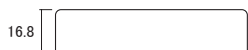
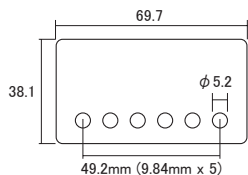

PUC-10

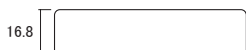
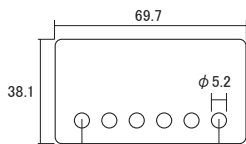

PUC-104

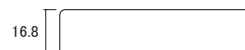
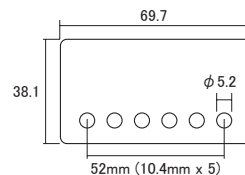

Item#	Polepiece Spacing	Color/Finish	Material
PC-HX	N/A	Black	Plastic
PUC-98G	49.2mm (9.84mm x 5)	Gold	Nickel-silver
PUC-98N	49.2mm (9.84mm x 5)	Nickel	Nickel-silver
PUC-10G	50.0mm (10.0mm x 5)	Gold	Nickel-silver
PUC-10N	50.0mm (10.0mm x 5)	Nickel	Nickel-silver
PUC-104G	52.0mm (10.4mm x 5)	Gold	Nickel-silver
PUC-104N	52.0mm (10.4mm x 5)	Nickel	Nickel-silver

Master Relic Collection Pickup Cover Set



Shallow dimple on the polepiece holes, worn surface with faint shadow marks left from the strings.

Item#	Description
MRC-HBPCN-SET	Aged Nickel, 2/SET



MRC-HBPCN-SET

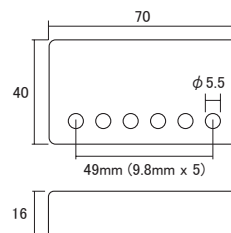

Bass Pickup Covers



PB type Pickup Covers



OD-PB-CB

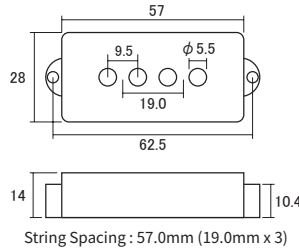

Item#	Description
OD-PB-CB	Black (Glossy), 2/SET

JB type Pickup Covers

For Neck position



OD-JB-CBF

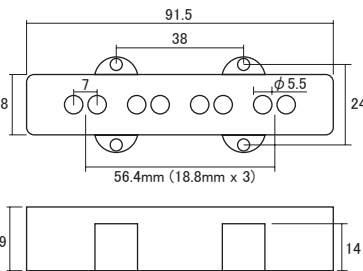

Item#	Description
OD-JB-CBF	Black (Glossy), Neck
OD-JB-CWF	White (Glossy), Neck

For Bridge position



OD-JB-CWR

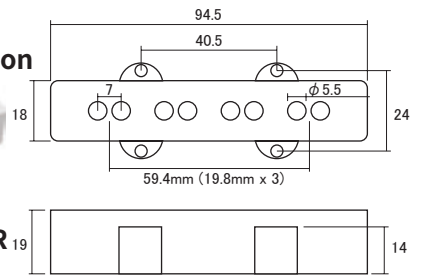

Item#	Description
OD-JB-CBR	Black (Glossy), Bridge
OD-JB-CWR	White (Glossy), Bridge

Pickup Fence



Screws included.

Item#	Finish
PF-C	Chrome

PF-C

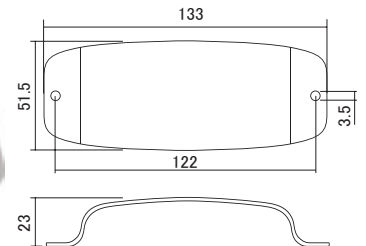

Pickup Height Foam



PB type Pickup Height Foam

Comes with copper plate and wire for grounding.

HAJ-P



Item#	Description
HAJ-P	Black, 2/SET

JB type Pickup Height Foam

Comes with copper plate and wire for grounding.

HAJ-J



Item#	Description
HAJ-J	Black

Pickup Springs

HOSCO®
Pack

Item#	Length	Shape
PG08	8 mm	Tapered
PG17	17 mm	Tapered
PG21	21 mm	Straight
PG27	27 mm	Straight
PG30	30 mm	Straight
PG42	42 mm	Straight

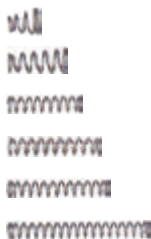

Polepiece Screws

HOSCO®
Pack

Item#	Size	Finish
PL19G	3 x 19 mm	Gold
PL19N	3 x 19 mm	Nickel



Pickups

Guitar Pickups

Wilkinson Single-coil Pickups Made in Japan

Vintage style staggered polepieces (Alnico 5 magnet).

Coil wire : Enameled copper wire

Middle pickups are reverse-wound / reverse-polarity.

Bridge pickups are slightly overwound for better balance.

Comes with a plastic box. Mounting screws included. (Nickel-plated)

Polepiece spacing : 52.5mm (10.5mm x 5)



WCLS



WHS

Standard version

Item#	Position	Color	DC Resist.	Reso. Peak	Wire Gauge	No. of Winds
WCLS-NB	Neck	Black	5.20K	7.4KHz	0.06mm	8,000
WCLS-NW	Neck	White	5.20K	7.4KHz	0.06mm	8,000
WCLS-NC	Neck	Cream	5.20K	7.4KHz	0.06mm	8,000
WCLS-MB	Middle	Black	5.20K	7.4KHz	0.06mm	8,000
WCLS-MW	Middle	White	5.20K	7.4KHz	0.06mm	8,000
WCLS-MC	Middle	Cream	5.20K	7.4KHz	0.06mm	8,000
WCLS-BB	Bridge	Black	6.28K	6.1KHz	0.06mm	9,500
WCLS-BW	Bridge	White	6.28K	6.1KHz	0.06mm	9,500
WCLS-BC	Bridge	Cream	6.28K	6.1KHz	0.06mm	9,500

Hotter version of WCLS

Item#	Position	Color	DC Resist.	Reso. Peak	Wire Gauge	No. of Winds
WHS-NB	Neck	Black	6.28K	7.4KHz	AWG43	9,500
WHS-NW	Neck	White	6.28K	7.4KHz	AWG43	9,500
WHS-NC	Neck	Cream	6.28K	7.4KHz	AWG43	9,500
WHS-MB	Middle	Black	6.28K	7.4KHz	AWG43	9,500
WHS-MW	Middle	White	6.28K	7.4KHz	AWG43	9,500
WHS-MC	Middle	Cream	6.28K	7.4KHz	AWG43	9,500
WHS-BB	Bridge	Black	5.20K	7.0KHz	AWG43	10,000
WHS-BW	Bridge	White	5.20K	7.0KHz	AWG43	10,000
WHS-BC	Bridge	Cream	5.20K	7.0KHz	AWG43	10,000

Pickups

Guitar Pickups

Wilkinson TL type Pickups Made in Japan

Great combination for classical sound.

Magnet : Alnico 5 / Coil wire : Enameled copper wire

Comes with a plastic box. Mounting screws included. (Nickel-plated)

Polepiece spacing : 55.0mm (11.0mm x 5)



Item#	Position	Finish/Color	DC Resist.	Reso. Peak	Wire Gauge	No. of Winds
WT-N	Neck	Nickel	4.66K	12.0KHz	0.06mm	6,000
WT-B	Bridge	Black	5.88K	7.5KHz	0.06mm	7,000

Wilkinson Humbuckers w/Covers Made in Japan

Classic style Humbuckers with Nickel-silver cover.

Magnet : Alnico 5 / Coil wire : Enameled copper wire

DC Resist. : 8.43K / Reso. Peak : 7.7KHz

Comes with a plastic box. Mounting screws included. (Nickel-plated)

Polepiece spacing for Neck : 49.0mm (9.8mm x 5)

Polepiece spacing for Bridge : 52.5mm (10.5mm x 5)



Item#	Position	Color	Wire Gauge	No. of Winds
WCHV-FB	Neck	Black	0.06mm	5,200
WCHV-FC	Neck	Cream	0.06mm	5,200
WCHV-RB	Bridge	Black	0.06mm	5,200
WCHV-RC	Bridge	Crean	0.06mm	5,200

Wilkinson Humbuckers w/o Covers Made in Japan

Open coil style Humbuckers. Higher output than WCHV.

Magnet : Alnico 5 / Coil wire : Enameled copper wire

DC Resist. : 8.66K / Reso. Peak : 6.6KHz

Comes with a plastic box. Mounting screws included. (Nickel-plated)

Polepiece spacing for Neck : 49.0mm (9.8mm x 5)

Polepiece spacing for Bridge : 52.5mm (10.5mm x 5)



Item#	Position	Color	Wire Gauge	No. of Winds
WHCLV-FB	Neck	Black	AWG42	5,000
WHCLV-FC	Neck	Cream	AWG42	5,000
WHCLV-RB	Bridge	Black	AWG42	5,000
WHCLV-RC	Bridge	Crean	AWG42	5,000

Wilkinson P-90 type Pickups Made in Japan

Bridge pickups are reverse-wound / reverse-polarity.

Magnet : Alnico 5 / Coil wire : Enameled copper wire

Comes with a plastic box. Mounting screws included. (Nickel-plated)

Polepiece spacing : 50.0mm (10.0mm x 5)



Item#	Position	Color	DC Resist.	Reso. Peak	Wire Gauge	No. of Winds
WP90V-FB	Neck	Black	5.95K	6.8KHz	AWG42	8,000
WP90V-FC	Neck	Cream	5.95K	6.8KHz	AWG42	8,000
WP90V-RB	Bridge	Black	5.95K	6.8KHz	AWG42	8,000
WP90V-RC	Bridge	Cream	5.95K	6.8KHz	AWG42	8,000
WP90V-HB	Hot-ver.	Black	5.20K	7.4KHz	AWG42	10,000
WP90V-HC	Hot-ver.	Cream	5.20K	7.4KHz	AWG42	10,000

Retro Tone Pickups

レトロトーンピックアップス

Retro Tone Pickups is a workshop who has produced pickups for more than 10 years.

Especially, their Jazzmaster® type pickups are famous in Japan and theirs are the first choice for many Jazz master® players in Japan. All of the following pickups are hand-made in Japan.

JM-58 Velvetone

Rich magnetic lines happen from the edges of the unbeveled magnets and receive a string vibration well so that your guitar sound will bite. The traditional Formvar wire that was used in 50s makes rich harmonics. By winding it at proper turns, a pickup delivers a thick deep sound and cuts a harsh high tone. Good quality wax-potted.



Unbeveled staggered polepieces (Alnico 5 magnet).
AWG42 heavy formvar wire.
Pickup covers are not included.
Polepiece spacing : 51.0mm (10.2mm x 5)

Item#	Position	DC Resist.	Note
JM-58N	Neck	7.4K	North Up
JM-58B	Bridge	9.3K	South Up

WRB-72 Moon Walking

Alternative Wide Range Humbucker by analyzing Fender® original, Fender® Japan, and Fender® Mexico. More natural and brighter sound than Fender® original.



Unbeveled polepieces (Alnico 3 magnet).
AWG42 plain enamel wire.
Pickup cover size : 80mm x 45mm
Polepiece spacing : 55.0mm (11.0mm x 5)

Item#	Position	DC Resist.
WRB-72	N/A	9.0K

TL-54 Bottled Message

The TL-54 Bottled Message was developed by reviewing the "blurry" tone of the neck pickup of Telecaster®. It was designed to get a clean brilliant high range, tight low-mid range, proper harmonic overtone, and rich three dimensional effect. Good quality wax-potted.



Unbeveled polepieces (Alnico 5 magnet).
AWG42 plain enamel wire.
Polepiece spacing : 50.5mm (10.1mm x 5)

Item#	Position	DC Resist.
TL-54	Neck	5.6K

TL-55 Pain King

The TL-55 Pain King is produced by blending the elements like unbeveled staggered Alnico 5 magnets (with a raised D and G), plain enamel wire, copper-plated baseplate, cloth wire, and so on properly, which makes crispy but thick sound, well defined and quick response for rich low-mid range and overtone. Good quality wax-potted.



Unbeveled staggered polepieces (Alnico 5 magnet).
AWG42 plain enamel wire.
Polepiece spacing : 55.0mm (11.0mm x 5)

Item#	Position	DC Resist.
TL-55	Bridge	7.8K

Single-coil Pickups

The best choice of replacement for vintage guitars. Staggered or Flat polepieces.

Magnet : Alnico 5 / DC Resist. : 5.8K

Coil wire : Plain enamel (AWG42) / Number of winds : 7,800

Polepiece spacing : 52.5mm (10.5mm x 5)

Screws & springs included.

Staggered polepieces

Item#	Color
SS-1W	White
SS-1B	Black
SS-1C	Cream
SS-1M	Mint



Flat polepieces

Item#	Color
SS-1FW	White
SS-1FB	Black
SS-1FC	Cream
SS-1FM	Mint



Reverse-wound / Reverse-polarity

Item#	Color
SS-1RW	White
SS-1RB	Black
SS-1RC	Cream
SS-1RM	Mint

Reverse-wound / Reverse-polarity

Item#	Color
SS-1FRW	White
SS-1FRB	Black
SS-1FRC	Cream
SS-1FRM	Mint

Economy model

Magnet : Ferrite

Coil wire : Enameled copper wire (AWG43) / Number of winds : 7,700

Polepiece spacing : 52.5mm (10.5mm x 5)

Item#	Description
PU-SCF	Single-coil pickup, White



TL type Pickups

Economy model

Magnet : Ferrite

Coil wire : Enameled copper wire (0.06mm) / Number of winds : 7,500 (TCF) & 8,000 (TCR)

Polepiece spacing : 55.0mm (11.0mm x 5)

Item#	Description
PU-TCF	Neck, Chrome
PU-TCR	Bridge, Black

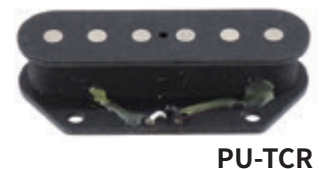

Humbuckers

The CP-1 and CP-2 humbuckers are designed to get the real PAF sound, making the new guitar's tone to vintage like. CP-2 has a Nickel-silver pickup cover available in nickel and gold.

Magnet : Alnico 3 (CP-1) / Original designed Alnico ALMAX (CP-2)

Polepiece spacing for Neck : 49.5mm (9.9mm x 5) / Polepiece spacing for Bridge : 52.5mm (10.5mm x 5)

Screws & springs included.



CP-1



CP-2

Item#	Position	Color/Finish	DC Resist.	Coil Wire	Wire Gauge	No. of Winds
CP-1N	Neck	Black, No cover	8.4K	Polyurethane	AWG42	5,200
CP-1B	Bridge	Black, No cover	8.4K	Polyurethane	AWG42	5,200
CP-2NN	Neck	Nickel	7.8K	Plain enamel	AWG42	5,500
CP-2NG	Neck	Gold	7.8K	Plain enamel	AWG42	5,500
CP-2BN	Bridge	Nickel	7.8K	Plain enamel	AWG42	5,500
CP-2BG	Bridge	Gold	7.8K	Plain enamel	AWG42	5,500

Economy model

Magnet : Ferrite

Coil wire : Enameled copper wire (AWG43) / Number of winds : 5,000

Polepiece spacing : 52.5mm (10.5mm x 5)

Item#	Description
PU-LPH	Humbucker, Black, No cover



PU-LPH

(without mounting ring)

Wide Range Humbucker

Magnet : Alnico 3 / DC Resist. : 10.5K

Coil wire : Polyurethane (AWG42.5) / Number of winds : 6,150

Polepiece spacing : 54.5mm (10.9mm x 5)

Screws & springs included.

Item#	Description
PU-WRH	Wide Range Humbucker, Chrome



PU-WRH

P-90 type Pickups

Soap-bar type w/mesh-shielded single conductor wire. Fat mid range tone.

Magnet : Alnico 5 / DC Resist. : 8.0K

Coil wire : Polyurethane (AWG42) / No. of winds : 10,000

Polepiece spacing : 50.0mm (10.0mm x 5)



SB-90B

Item#	Color
SB-90B	Black
SB-90I	Cream

Economy model

Magnet : Alnico 5 / DC Resist. : 5.95K

Coil wire : Enameled copper wire (AWG42)

Number of winds : 8,000

Polepiece spacing : 50.0mm (10.0mm x 5)



PU-TVS



PU-TVE

Item#	Description
PU-TVS	Soap-bar type, Black
PU-TVE	Dog-ear type, Black

Jazz Guitar Pickups

Sweet tone.
 Magnet : Alnico 5 / DC Resist. : 8.0K
 Coil wire : Polyurethane (AWG42.5) / Number of winds : 5,000
 Polepiece spacing : 50.0mm (10.0mm x 5)



JZ-NECK



JZ-SIDE

Item#	Description
JZ-NECK-G	Neck, Gold
JZ-NECK-N	Neck, Nickel

Item#	Description
JZ-SIDE-G	Side, Gold
JZ-SIDE-N	Side, Nickel

JG type Pickups

Magnet : Alnico 5 / DC Resist. : 6.5 - 7.0K
 Coil wire : Plain enamel (AWG42) / No. of winds : 8,600
 Polepiece spacing : 51.0mm (10.2mm x 5)
 Pickup cover : Cream

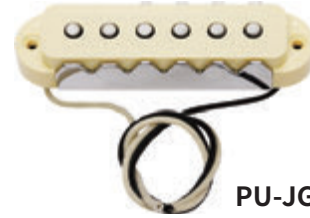

PU-JG

Item#	Description
PU-JG-F	Neck
PU-JG-R	Bridge

Bass Pickups

Wilkinson PB type Pickups Made in Japan

Magnet : Alnico 5
 DC Resist. : 9.26K / Reso. Peak : 6.0KHz
 Coil wire : Enameled copper wire (AWG42)
 Number of winds : 9,000
 String spacing : 57.0mm (19.0mm x 3)
 Comes with a plastic box. Mounting screws included.



WBP-B

Item#	Description
WBP-B	Black, 2/SET

PB type Pickups

The reproduction of '50s original bass pickups makes the best balanced tone.

Magnet : Alnico 5 / DC Resist. : 8.5K
 Coil wire : Plain enamel (AWG42) / Number of winds : 8,800
 String spacing : 57.0mm (19.0mm x 3)
 Screws included.



PB-1

Item#	Description
PB-1	Black, 2/SET

Economy model

Magnet : Ferrite
 Coil wire : Enameled copper wire (0.06mm) / Number of winds : 9,000
 String spacing : 57.0mm (19.0mm x 3)

Item#	Description
PU-PBF	Black, 2/SET



PU-PBF

Bass Pickups

Wilkinson JB type Pickups

Made in Japan
 Magnet : Alnico 5
 DC Resist. : 7.15K / Reso. Peak : 4.8KHz
 Coil wire : Enameled copper wire (AWG42)
 Number of winds : 8,000
 String spacing for Neck : 56.4mm (18.8mm x 3)
 String spacing for Bridge : 59.4mm (19.8mm x 3)
 Comes with a plastic box. Mounting screws included.



Item#	Description
WBJ-NB	Neck, Black
WBJ-BB	Bridge, Black

JB type Pickups

The reproduction of '60s original bass pickups makes the best balanced tone.

Magnet : Alnico 5
 Coil wire : Plain enamel (AWG42) / Number of winds : 8,600
 String spacing for Neck : 56.4mm (18.8mm x 3)
 String spacing for Bridge : 59.4mm (19.8mm x 3)
 Screws included.



Item#	Position	Color	DC Resist.
CJ-1N	Neck	Black	7.8K
CJ-1B	Bridge	Black	8.0K

Economy model

Magnet : Ferrite
 Coil wire : Enameled copper wire (0.06mm) / Number of winds : 8,000
 String spacing for Neck : 56.4mm (18.8mm x 3)
 String spacing for Bridge : 59.4mm (19.8mm x 3)

Item#	Description
PU-JBF-F	Neck, Black
PU-JBF-R	Bridge, Black



OPB type Pickups

Magnet : Alnico 5
 DC Resist. : 7.7K
 Coil wire : Plain enamel (AWG43) / Number of winds : 7,800
 Polepiece spacing : 54.0mm (18.0mm x 3)

Item#	Color
PU-OPB	Black



Pickguards

Electric Guitar Pickguards HOSCO Pack

Material : PVC plastic

***Color Reference**

- B1P: Matte Black
- B3P: Black/WH/BK
- W1P: White
- W3P: White/BK/WH
- G3P: Mint Green/BK/Mint
- IVO: Cream

- P3P: White Pearloid/WH/BK/WH
- BKT4P: Black Tortoise/WH/BK/WH
- T4PM: Tortoise/Mint Green/BK/Mint
- NRT4P: Red Tortoise/WH/BK/WH (JG, PB, & JB)
- PI05: Yellowish Pearloid/WH/BK/WH

The color of PI05 will be changed from the current white to parchment white once the current stock runs out.

ST type Pickguards (S-S-S)

Item#	Color (Mounting Holes)
SC-B1P	Black 1-ply (8)
SC-B3P	Black 3-ply (11)
SC-W1P	White 1-ply (8)
SC-W3P	White 3-ply (11)
SC-G3P	Mint Green 3-ply (11)

Item#	Color (Mounting Holes)
SC-P3P	White Pearloid 4-ply (11)
SC-PI05	Yellowish Pearloid 4-ply (11)
SC-BKT4P	Black Tortoise 4-ply (11)
SC-T4PM	Tortoise/Mint 4-ply (11)
SC-68/69W4P	'68-69, White 4-ply, Pearl on Back (11)

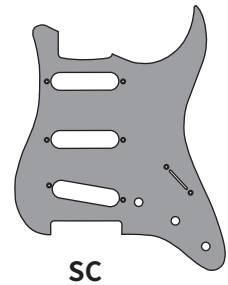

ST type Pickguards (No Holes)

Item#	Color (Mounting Holes)
SC-B1P-2	Black 1-ply (8)
SC-B3P-2	Black 3-ply (11)
SC-W1P-2	White 1-ply (8)
SC-W3P-2	White 3-ply (11)
SC-G3P-2	Mint Green 3-ply (11)

Item#	Color (Mounting Holes)
SC-P3P-2	White Pearloid 4-ply (11)
SC-PI05-2	Yellowish Pearloid 4-ply (11)
SC-BKT4P-2	Black Tortoise 4-ply (11)
SC-T4PM-2	Tortoise/Mint 4-ply (11)

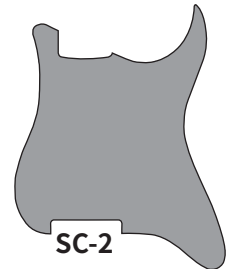

ST type Pickguards (H-S-S)

Item#	Color (Mounting Holes)
SC-B1P-3	Black 1-ply (8)
SC-B3P-3	Black 3-ply (11)
SC-W1P-3	White 1-ply (8)
SC-W3P-3	White 3-ply (11)
SC-G3P-3	Mint Green 3-ply (11)

Item#	Color (Mounting Holes)
SC-P3P-3	White Pearloid 4-ply (11)
SC-PI05-3	Yellowish Pearloid 4-ply (11)
SC-BKT4P-3	Black Tortoise 4-ply (11)
SC-T4PM-3	Tortoise/Mint 4-ply (11)

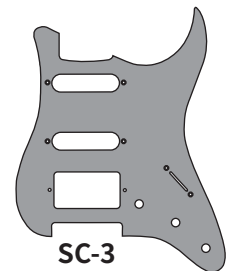

ST type Pickguards (1H)

Item#	Color (Mounting Holes)
SC-B1P-4	Black 1-ply (8)
SC-B3P-4	Black 3-ply (11)
SC-W1P-4	White 1-ply (8)
SC-W3P-4	White 3-ply (11)
SC-G3P-4	Mint Green 3-ply (11)

Item#	Color (Mounting Holes)
SC-P3P-4	White Pearloid 4-ply (11)
SC-PI05-4	Yellowish Pearloid 4-ply (11)
SC-BKT4P-4	Black Tortoise 4-ply (11)
SC-T4PM-4	Tortoise/Mint 4-ply (11)

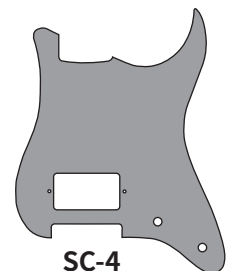

Vintage style ST type Pickguards

**HOSCO®
Pack**

These vintage style pickguards are reproduced under the original specification like shape, position and number of screw holes, pot holes, switch slot, and pickup holes.

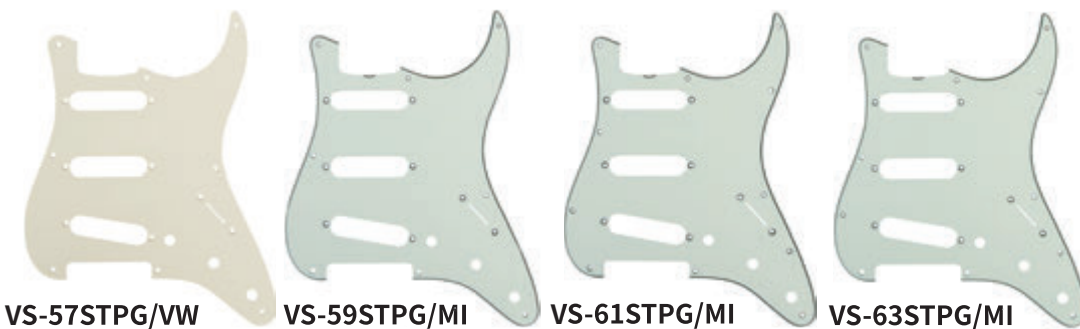

Item#	Description (Mounting Holes)
VS-57STPG/VW	'54-'58, Vintage White 1-ply (8)
VS-59STPG/MI	'59, ('54-'58), Mint Cream 3-ply (8)
VS-61STPG/MI	'60-'62, Mint Cream 3-ply (11)
VS-63STPG/MI	'63-'65, ('66-'74), Mint Cream 3-ply (11)

Vintage style Aluminum Ground Plates

Useful for noise reduction.
Fits our Vintage style ST pickguards.

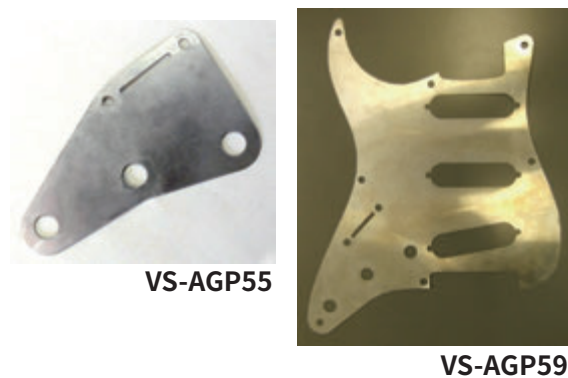

Item#	Description (Mounting Holes)
VS-AGP55	'54-'58, Control area only
VS-AGP59	'58-'59 (8)
VS-AGP61	'60-'62 (11)
VS-AGP63	'63-'65 ('66-'74), (11)

Aluminum Ground Sheets

Useful for noise reduction. Self-adhesive.
You can cut these ground sheets easily as you like.

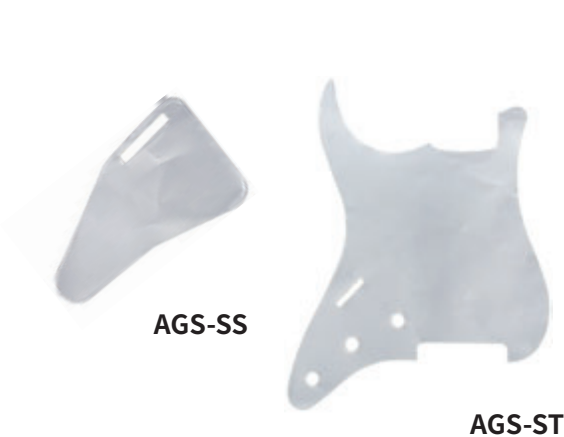

Item#	Description
AGS-SS	Control area only
AGS-ST	ST type
AGS-SQ	Blank, 530 x 300 mm

Master Relic Collection ST type Pickguards



Item#	Description (Mounting Holes)
MRC-ST57W1	Vintage White 1-ply (8)
MRC-ST63MI3	Mint Cream 3-ply (11)



MRC-ST57W1



MRC-ST63MI3

ST type Relic Pickguards

Economy models to enjoy the aged appearance easily.



SC-W1P-R57



SC-G3P-R62



SC-W3P-R72

Item#	Description (Mounting Holes)
SC-W1P-R57	'57, Relic White 1-ply (8)
SC-G3P-R62	'62, Relic Mint Green 3-ply (11)
SC-W3P-R72	'72, Relic White 3-ply (11)

TL type Pickguards

*Color Reference

- B1P: Matte Black
- B3P: Black/WH/BK
- W1P: White
- W3P: White/BK/WH
- G3P: Mint Green/BK/Mint
- IVO: Cream

- P3P: White Pearloid/WH/BK/WH
- BKT4P: Black Tortoise/WH/BK/WH
- T4PM: Tortoise/Mint Green/BK/Mint
- NRT4P: Red Tortoise/WH/BK/WH (JG, PB, & JB)
- PI05: Yellowish Pearloid/WH/BK/WH

The color of PI05 will be changed from the current white to parchment white once the current stock runs out.

Item#	Color (Mounting Holes)
TC-B1P	Black 1-ply (5)
TC-B3P	Black 3-ply (8)
TC-W1P	White 1-ply (5)
TC-W3P	White 3-ply (8)
TC-G3P	Mint Green 3-ply (8)

Item#	Color (Mounting Holes)
TC-P3P	White Pearloid 4-ply (8)
TC-PI05	Yellowish Pearloid 4-ply (8)
TC-BKT4P	Black Tortoise 4-ply (8)
TC-T4PM	Tortoise/Mint 4-ply (8)

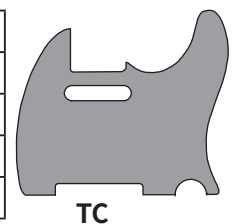

TC

TL type Bakelite Pickguards

HOSCO
Pack

In 1950's, Bakelite was popular material for electric guitar pickguards, but it disappeared in 1960's. Our bakelite pickguards are for vintage lovers.
Thickness : 2.0 mm Color : Matte Black

Item#	Description (Mounting Holes)
TC-BL-B1P	Black 1-ply (5)
TC-BL-EQ	Black 1-ply, No PU hole (5)



Vintage style TL type Pickguards

These vintage style pickguards are reproduced under the original specification like shape, position and number of screw holes, pot holes, switch slot, and pickup holes.

Item#	Description (Mounting Holes)
VS-60TLPG/VW	'59, Vintage White 1-ply (8)
VS-64TLPG/MI	'64, Mint Cream 3-ply (8)

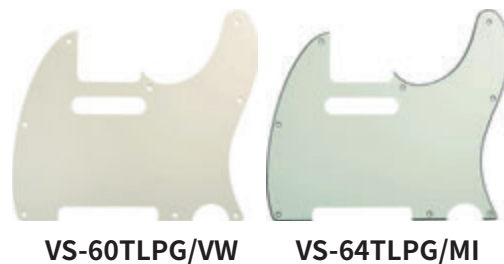

Master Relic Collection TL type Pickguards

Item#	Color (Mounting Holes)
MRC-TL60W1	Relic Vintage White 1-ply (8)
MRC-TLBL	Relic Black (Bakelite) 1-ply (5)



TL type Relic Pickguards

Economy models to enjoy the aged appearance easily.

Item#	Description (Mounting Holes)
TC-52RB1P	'52, Relic Black 1-ply (5)
TC-62RW1P	'62, Relic White 1-ply (8)



***Color Reference**



- B1P: Matte Black
- B3P: Black/WH/BK
- W1P: White
- W3P: White/BK/WH
- G3P: Mint Green/BK/Mint
- IVO: Cream

- P3P: White Pearloid/WH/BK/WH
- BKT4P: Black Tortoise/WH/BK/WH
- T4PM: Tortoise/Mint Green/BK/Mint
- NRT4P: Red Tortoise/WH/BK/WH (JG, PB, & JB)
- PI05: Yellowish Pearloid/WH/BK/WH

The color of PI05 will be changed from the current white to parchment white once the current stock runs out.

JM type Pickguards

Item#	Color
JM-B3P	Black 3-ply
JM-W3P	White 3-ply
JM-G3P	Mint Green 3-ply
JM-P3P	White Pearloid 4-ply
JM-BKT4P	Black Tortoise 4-ply
JM-IVO	Cream 1-ply

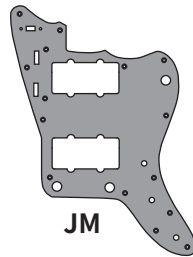

JG type Pickguards

Item#	Color
JG-B1P	Black 1-ply
JG-B3P	Black 3-ply
JG-W1P	White 1-ply
JG-W3P	White 3-ply
JG-G3P	Mint Green 3-ply
JG-NRT4P	Red Tortoise 4-ply

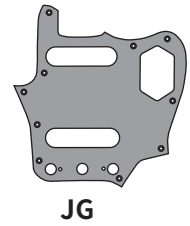

LP type Pickguards

Item#	Color
LP-B3P	Black 3-ply
LP-IVO	Cream 1-ply

*Bracket & screws are included.

Item#	Description
LP-59LI	'59, Light Cream 1-ply
LP-56I-P90	'56, for P-90, Cream 1-ply

*Bracket & screws are NOT included.

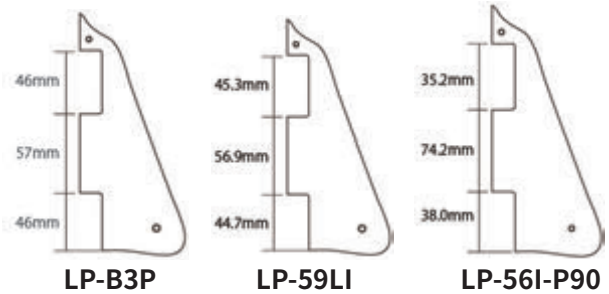
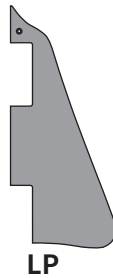

LP-59LI



LP-56I-P90

**Master Relic Collection
LP type Pickguards**

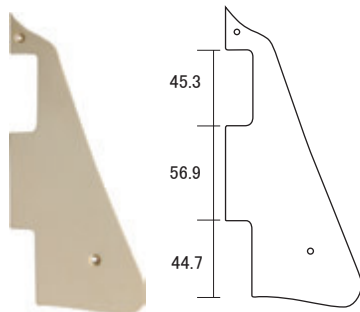

Item#	Description
MRC-LP59IV	'59, Cream 1-ply

*Bracket & screws are NOT included.

LP type Relic Pickguards

Economy model to enjoy the aged appearance easily.

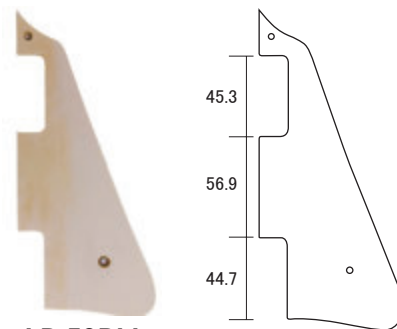

Item#	Description
LP-59RLI	'59, Relic Light Cream 1-ply

*Bracket & screws are NOT included.

***Color Reference**



- B1P: Matte Black
- B3P: Black/WH/BK
- W1P: White
- W3P: White/BK/WH
- G3P: Mint Green/BK/Mint
- IVO: Cream

- P3P: White Pearloid/WH/BK/WH
- BKT4P: Black Tortoise/WH/BK/WH
- T4PM: Tortoise/Mint Green/BK/Mint
- NRT4P: Red Tortoise/WH/BK/WH (JG, PB, & JB)
- PI05: Yellowish Pearloid/WH/BK/WH

The color of PI05 will be changed from the current white to parchment white once the current stock runs out.

SG type Pickguards

Item#	Color
SG-B3P	Black 3-ply
SG-W3P	White 3-ply

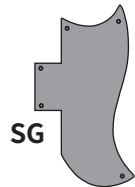

SG Custom type Pickguards

Item#	Color
SM-B3P	Black 3-ply
SM-W3P	White 3-ply

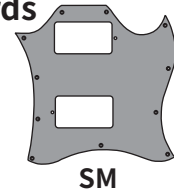

FV type Pickguards

Item#	Color
FV-B3P	Black 3-ply
FV-W3P	White 3-ply

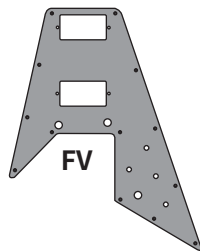

EX type Pickguards

Item#	Color
EX-B1P	Black 1-ply
EX-B3P	Black 3-ply
EX-W1P	White 1-ply
EX-W3P	White 3-ply

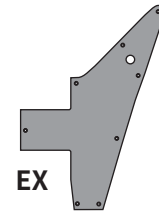

FB type Pickguards

Item#	Color
FB-B3P	Black 3-ply
FB-W3P	White 3-ply

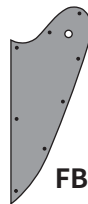

175 type Pickguards

Item#	Color
E1-B3P	Black 3-ply
E1-IVO	Cream 1-ply



335 type Pickguards

Item#	Color
E3-B3P	Black 3-ply
E3-IVO	Cream 1-ply



MU type Pickguards

Item#	Color
MU-B3P	Black 3-ply
MU-W3P	White 3-ply
MU-P3P	White Pearloid 4-ply
MU-BKT4P	Black Tortoise 4-ply

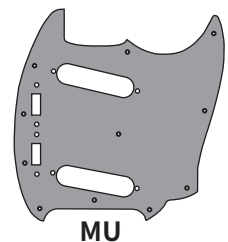

TL Thinline type Pickguards

Item#	Color
TT-P3P	White Pearloid 4-ply
TT-BKT4P	Black Tortoise 4-ply

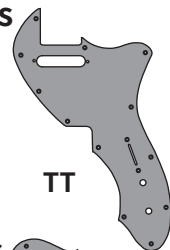

TL Deluxe type Pickguards

Item#	Color
TD-B3P	Black 3-ply
TD-W3P	White 3-ply

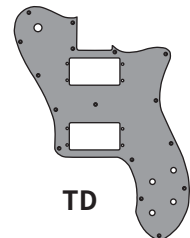

TL Custom type Pickguards

Item#	Color
TM-B3P	Black 3-ply
TM-W3P	White 3-ply
TM-P3P	White Pearloid 4-ply

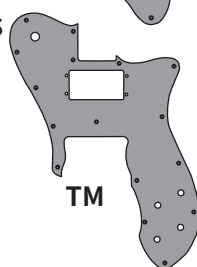

TL Humbucker type Pickguards

Item#	Color
TH-B1P	Black 1-ply
TH-B3P	Black 3-ply
TH-W1P	White 1-ply

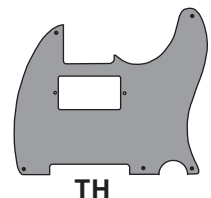

Pickguards

Electric Bass Pickguards HOSCO Pack

*Color Reference

B1P: Matte Black
 B3P: Black/WH/BK
 W1P: White
 W3P: White/BK/WH
 G3P: Mint Green/BK/Mint
 IVO: Cream

P3P: White Pearloid/WH/BK/WH
 BKT4P: Black Tortoise/WH/BK/WH
 T4PM: Tortoise/Mint Green/BK/Mint
 NRT4P: Red Tortoise/WH/BK/WH (JG, PB, & JB)
 PI05: Yellowish Pearloid/WH/BK/WH

The color of PI05 will be changed from the current white to parchment white once the current stock runs out.

MM type Pickguards

Current type with a slot for truss rod adjustment.

Item#	Color
MSN-B3P	Black 3-ply
MSN-W3P	White 3-ply

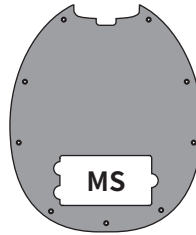

PB type Pickguards Mounting Holes : 13

Item#	Color
PB-B1P	Black 1-ply
PB-B3P	Black 3-ply
PB-W1P	White 1-ply
PB-W3P	White 3-ply
PB-G3P	Mint Green 3-ply

Item#	Color
PB-P3P	White Pearloid 4-ply
PB-PI05	Yellowish Pearloid 4-ply
PB-BKT4P	Black Tortoise 4-ply
PB-T4PM	Tortoise/Mint 4-ply
PB-NRT4P	Red Tortoise 4-ply

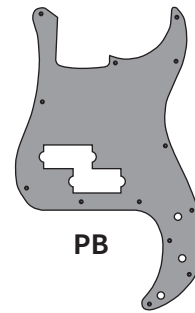

OPB type Pickguards

Item#	Color
OPB-B1P	Black 1-ply
OPB-B3P	Black 3-ply
OPB-W1P	White 1-ply
OPB-BL-B1P	Black 1-ply, Bakelite

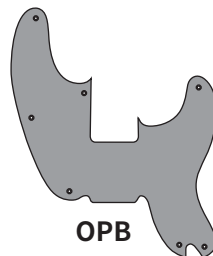

Master Relic Collection PB type Pickguards

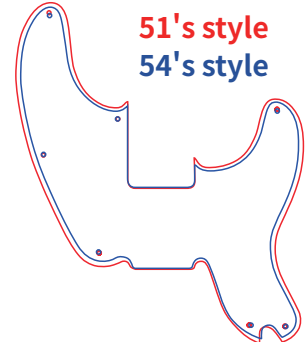

MRC-PB51BL

Item#	Description
MRC-PB51BL	'51, Black 1-ply, Bakelite
MRC-PB54BL	'54, Black 1-ply, Bakelite

JB type Pickguards Mounting Holes : 11

Item#	Color
JB-B1P	Black 1-ply
JB-B3P	Black 3-ply
JB-W1P	White 1-ply
JB-W3P	White 3-ply
JB-G3P	Mint Green 3-ply

Item#	Color
JB-P3P	White Pearloid 4-ply
JB-PI05	Yellowish Pearloid 4-ply
JB-BKT4P	Black Tortoise 4-ply
JB-T4PM	Tortoise/Mint 4-ply
JB-NRT4P	Red Tortoise 4-ply

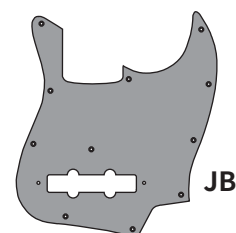

Aluminum Ground Materials



VS-AGP55



VS-AGP59



AGS-SS



AGS-ST

Vintage style Aluminum Ground Plates

Useful for noise reduction.
Fits our Vintage style ST pickguards.

Item#	Description (Mounting Holes)
VS-AGP55	'54-'58, Control area only
VS-AGP59	'58-'59 (8)
VS-AGP61	'60-'62 (11)
VS-AGP63	'63-'65 ('66-'74), (11)

Aluminum Ground Sheets

Useful for noise reduction. Self-adhesive.
You can cut these ground sheets easily as you like.

Item#	Description
AGS-SS	Control area only
AGS-ST	ST type
AGS-SQ	Blank, 530 x 300 mm

Acoustic Guitar Pickguards



Martin® type Pickguards

F-4002/T series have beautiful patterns like genuine materials. Self-adhesive.
Material : PVC plastic

Item#	Description
F-4002/T1	Tortoise, Brown
F-4002/T2	Shell, Light Brown
F-4002/T3	Shell, Spotted
F-4002/T4	Shell, Dark Brown
F-4001	Black
F-4001L	Black, Left-handed
F-4001BR	Brown
F-4001W	White
F-4001TR	Transparent
F-4001P	White Pearl
F-4002	Tortoise

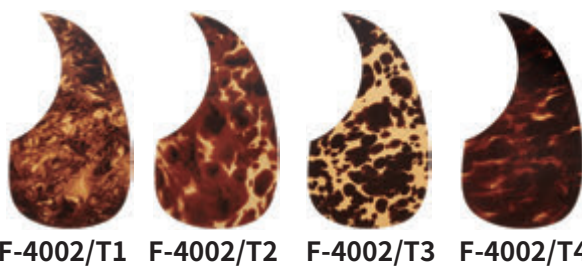

F-4002/T1 F-4002/T2 F-4002/T3 F-4002/T4



F-4001 F-4001BR F-4001W

F-4001TR F-4001P F-4002

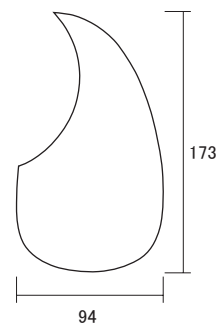

Archtop Guitar Pickguards



Gibson® type archtop pickguards with Nickel or Gold bracket.
Pickguard material : Acrylic

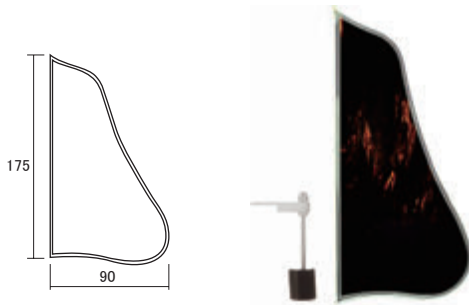

ATPGT-S

Small size

Item#	Color	Bracket
ATPGB-S	Black	Nickel
ATPGB-S/G	Black	Gold
ATPGT-S	Tortoise	Nickel
ATPGT-S/G	Tortoise	Gold

REVIVAL
REVIVAL

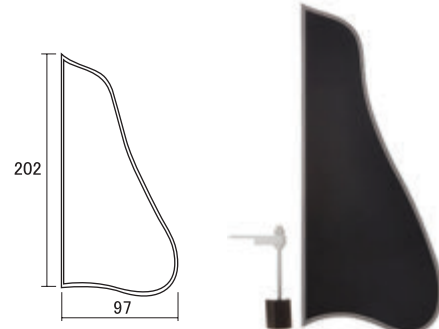

ATPGB-L

Large size

Item#	Color	Bracket
ATPGB-L	Black	Nickel
ATPGB-L/G	Black	Gold
ATPGT-L	Tortoise	Nickel
ATPGT-L/G	Tortoise	Gold

REVIVAL
REVIVAL

Pickguard Brackets



LP type Pickguard Brackets

Screws, bolt, washer, & nut included.



Item#	Finish
HK-50CS	Chrome
HK-50GS	Gold

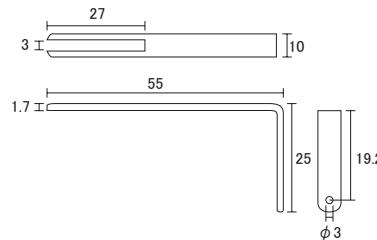

Master Relic Collection LP type Pickguard Bracket



Item#	Finish
MRC-LPBRC	Aged Chrome

L-shaped Archtop Pickguard Brackets

Screws, bolt, washer, & nut included.

Item#	Finish
HK-52NS	Nickel
HK-52GS	Gold

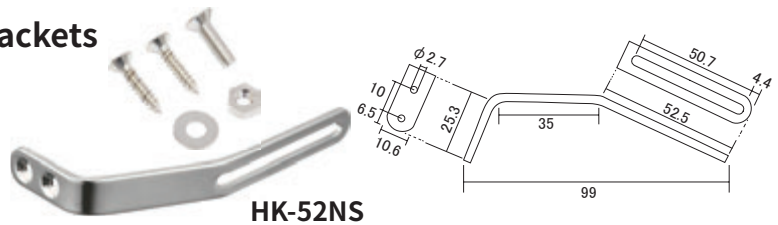

HK-52NS

Archtop Pickguard Brackets

Metal hardware with wooden block for gluing to the backside of the pickguard.
Screw included.

Item#	Finish
ATB-NS	Nickel
ATB-GS	Gold

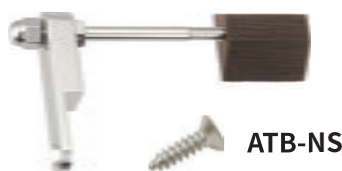

ATB-NS

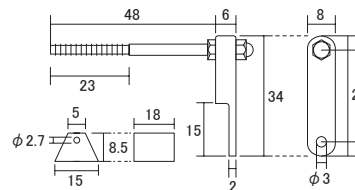

Blank Sheets



Pickguard Sheets for Electric Guitars & Basses

*Color Reference

- B1L: Matte Black
- B3L: Black/WH/BK
- W1L: White
- W3L: White/BK/WH
- G3L: Mint Green/BK/Mint
- IVOL: Cream
- P3L: Pearloid/WH/BK/WH
- PI05L: Yellowish Pearloid/WH/BK/WH
- BKT4P: Black Tortoise/WH/BK/WH
- T4PM: Tortoise/Mint Green/BK/Mint



Item#	Color	Size (L x W)
PG-B1L	Black 1-ply	300 x 450mm
PG-B3L	Black 3-ply	300 x 450mm
PG-W1L	White 1-ply	300 x 450mm
PG-W3L	White 3-ply	300 x 450mm
PG-G3L	Mint Green 3-ply	290 x 490mm
PG-IVOL	Cream 1-ply	300 x 450mm

Item#	Color	Size (L x W)
PG-P3L	White Pearloid 4-ply	300 x 450mm
PG-PI05L	Yellowish Pearloid 4-ply	300 x 450mm
PG-BKT4P	Black Tortoise 4-ply	290 x 450mm
PG-T4PM	Tortoise/Mint 4-ply	290 x 450mm

Pickguard Sheets for Acoustic Guitars

These blank sheets are the same materials as our Martin® type pickguards. F-PGT series have beautiful patterns like genuine materials. Self-adhesive. Material : PVC plastic

Item#	Color	Size (L x W x T)
F-PGBK	Black	290 x 220 x 0.5mm
F-PGCL	Clear	290 x 220 x 0.3mm



F-PGBK



F-PGCL

Item#	Color	Size (L x W x T)
F-PGWP	White Pearl	290 x 210 x 0.8mm
F-PGTS	Tiger Stripes	300 x 200 x 0.5mm

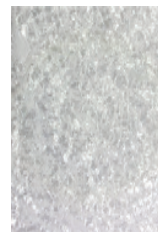

F-PGWP



F-PGTS

Item#	Color	Size (L x W x T)
F-PGT1	Tortoise, Brown	290 x 180 x 0.5mm
F-PGT2	Shell, Light Brown	290 x 180 x 0.5mm
F-PGT3	Shell, Spotted	290 x 180 x 0.5mm
F-PGT4	Shell, Dark Brown	290 x 180 x 0.5mm



F-PGT1

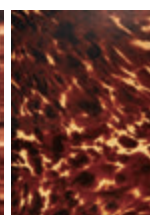

F-PGT2

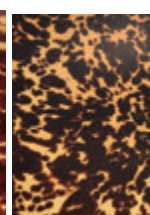

F-PGT3

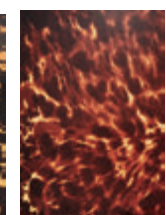

F-PGT4

Faceguard



Protect Picking Scratches

This is an ideal item to protect your instruments against scratches.
 If you are a retailer, you can use the Faceguard at your store when your customers try to play the instruments.
 Reusable. It is very easy to adhere and remove the Faceguard. You can change the instruments quickly.
 Can be used on glossy finished surface only.
 Three different types ready to use and one blank sheet for your original shape are available.
 Washable. When it cannot stick well because of dusts, please wash it with water and then it will work again.
 Material : PET plastic

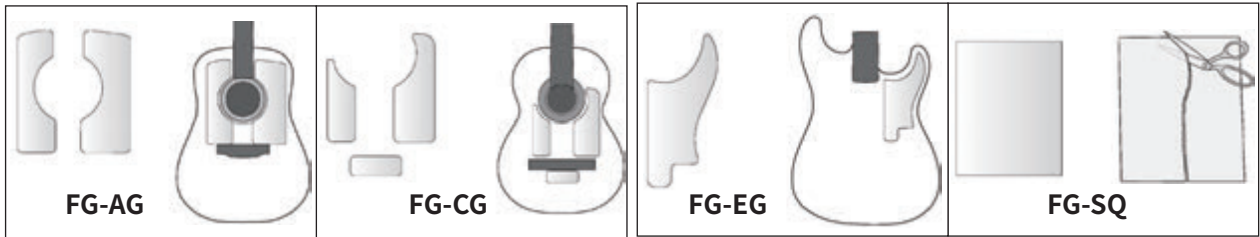

Item#	Description
FG-AG	For Acoustic guitars, 2/SET
FG-CG	For Classical guitars, 3/SET
FG-EG	For Electric guitars
FG-SQ	Blank sheet, 210 x 170 mm

Buckle Guard



The Buckle Guard is a protective item to prevent the backside of the instrument from damage by a buckle or buttons.
 Reusable. It is very easy to adhere and remove the Buckle Guard. You can change the instruments quickly.
 Can be used on glossy finished surface only.
 Two sizes are available.
 Washable. When it cannot stick well because of dusts, please wash it with water and then it will work again.
 Material : PET plastic

Item#	Description
BG-L	Large, 162 x 228 mm
BG-S	Small, 107 x 151 mm

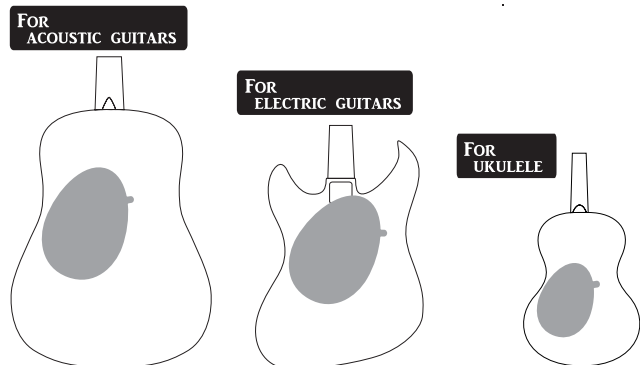

Plates

Backplates



ST type Backplates

Screws are NOT included.

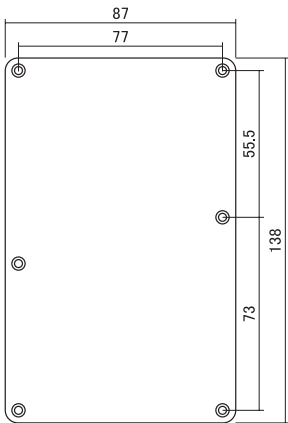
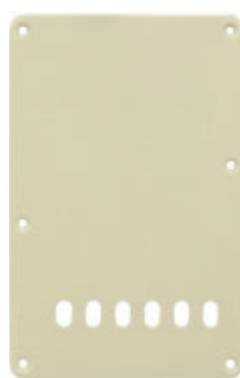

P-103 No string holes

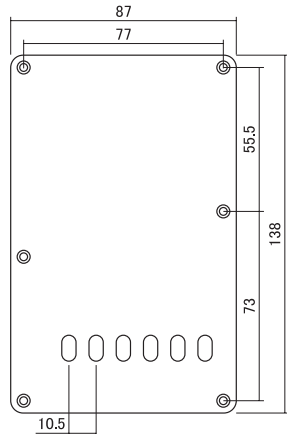

P-104 String spacing : 52.5mm (10.5mm x 5)

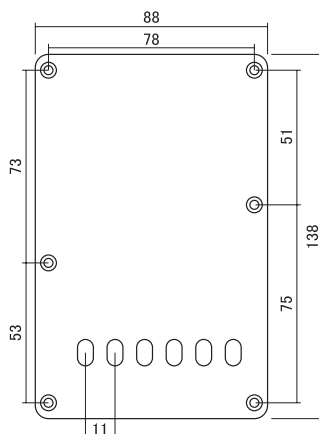

P-105 String spacing : 55.0mm (11.0mm x 5)
*Except P-105M

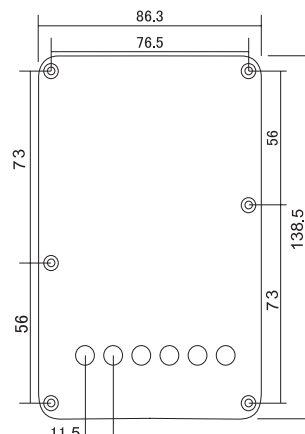

P-105-RH Round string holes
String spacing : 57.5mm (11.5mm x 5)

Item#	String Spacing	Color	Note
P-103B	No Holes	Black	
P-103W	No Holes	White	
P-104B	52.5mm (10.5mm x 5)	Black	
P-104W	52.5mm (10.5mm x 5)	White	
P-105B	55.0mm (11.0mm x 5)	Black	
P-105W	55.0mm (11.0mm x 5)	White	
P-105RW	55.0mm (11.0mm x 5)	Relic White	
P-105M	56.0mm (11.2mm x 5)	Mint Green 3-ply	
P-105MI	55.0mm (11.0mm x 5)	Mint Cream	
P-105P	55.0mm (11.0mm x 5)	Parchment White	
P-105W-RH	57.5mm (11.5mm x 5)	White	Round string holes
P-105RW-RH	57.5mm (11.5mm x 5)	Relic White	Round string holes

LP type Backplates 

LP-101 and LP-102 fit Historic Series (1994-2008) and the "translucent" Brown color looks like original. Screws are NOT included.

For Control cavity

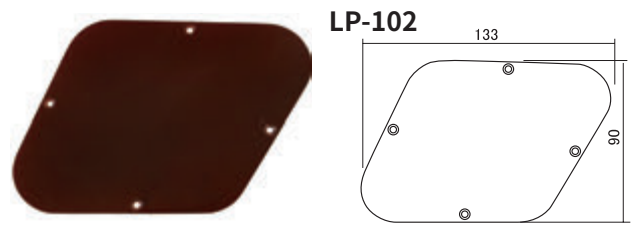
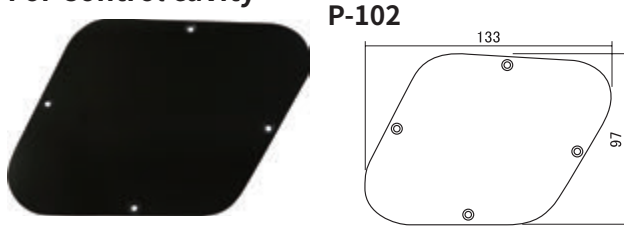

Item#	Color
P-102B	Black
P-102I	Cream

Item#	Description
LP-102BK	Black, fits Historic Series (1994-2008)
LP-102BR	Brown, fits Historic Series (1994-2008)

For Switch cavity

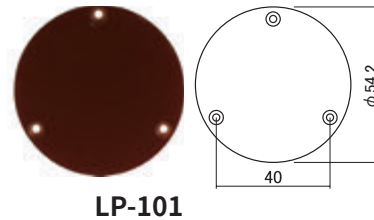
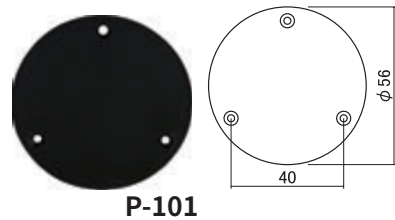

Item#	Color
P-101B	Black
P-101I	Cream

Item#	Description
LP-101BK	Black, fits Historic Series (1994~)
LP-101BR	Brown, fits Historic Series (1994~)

Control Plates 

JG type Control Plates

Finish : Chrome only
Screws included.

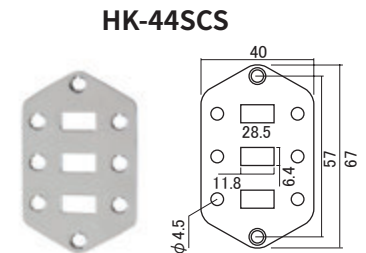
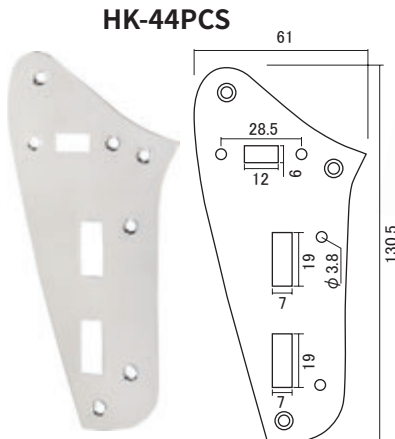

Item#	Description
HK-44PCS	Preset control plate
HK-44CCS	Master control plate
HK-44SCS	Pickup control plate

Control Plates



JB type Control Plate

Screws included.



JB-2CS

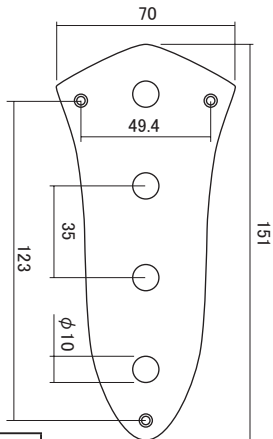

Item#	Finish
JB-2CS	Chrome

Vintage PB type Control Plate

Screws included.



HK-PBVPS

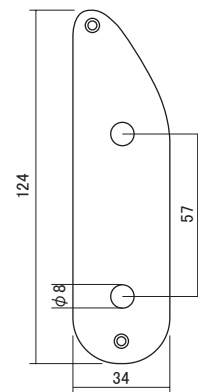

Item#	Finish
HK-PBVPS	Chrome

TL type Control Plate

This Nickel version is not produced on a regular basis.
Screws included.



CP-10NS

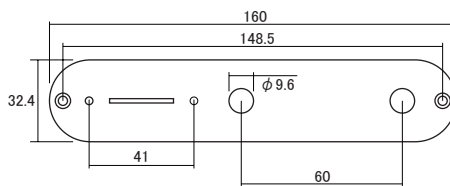

Item#	Finish
CP-10NS	Nickel

Neck Plate

GOTOH® Neck Plate



This Nickel version is not produced on a regular basis.
Screws included.



NBS-3NS

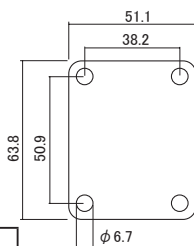

Item#	Finish
NBS-3NS	Nickel

Plastic Neck Shim



Molded plastic.
Thickness : 1.0mm



PD-10

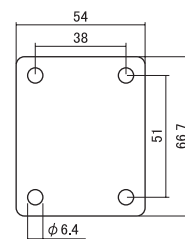

Item#	Color
PD-10	Black

Treble/Rhythm Plates

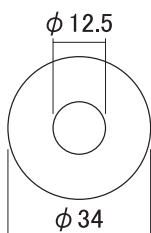

LP-SW-B



LP-SW-I

Item#	Color
LP-SW-B	Black
LP-SW-I	Cream

Jack Plates



Square type Jack Plates

LP-100 has square corners like vintage plates.
Screws are NOT included.

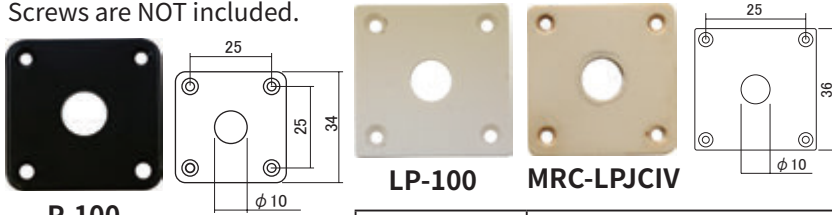

Material : Steel
Screws included.

Item#	Color
P-100B	Black,Plastic
P-100I	Cream,Plastic

Item#	Color
LP-100LI	Light Cream, Plastic
LP-100RLI	Relic Light Cream, Plastic
MRC-LPJCIV	Master Relic Collection, Cream,Plastic

Item#	Finish
JP-20C	Chrome

TL type Jack Plates

Material : Steel
Comes with a retainer clip.



Material : Brass

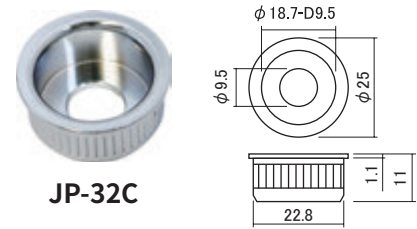

Item#	Finish
HK-15C	Chrome
MRC-TLJCC	Aged Chrome, Master Relic Collection

Item#	Finish
JP-32C	Chrome

GOTOH® Jack Plates

This Nickel version is not produced on a regular basis.
Screws included.

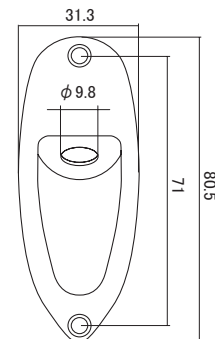
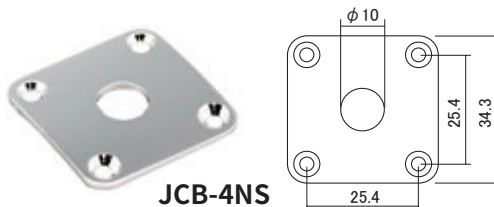

Item#	Shape	Finish
JCB-4NS	Square	Nickel
JCS-1NS	ST type	Nickel
JCB-2NS	Oval	Nickel

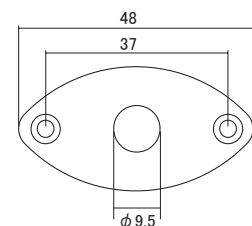

JG/JM type Related Parts

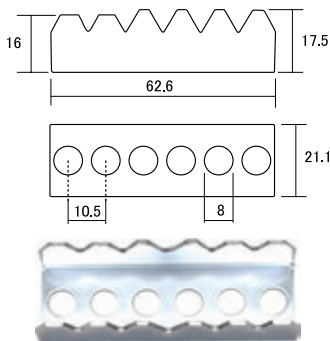

HK-44PCC

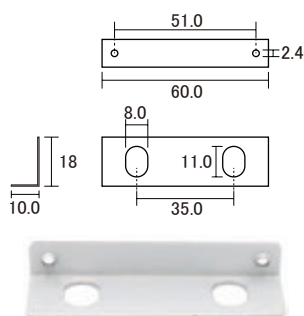

HK-44L/JG

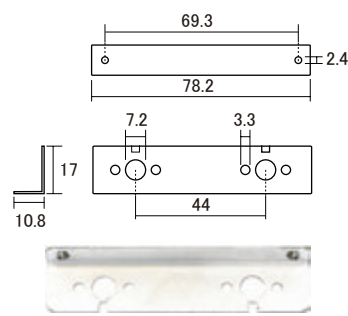

HK-44L/JM

Item#	Description
HK-44PCC	Pickup magnet claw, Chrome
HK-44L/JG	L-shaped Preset pot bracket for JG, w/Screws
HK-44L/JM	L-shaped Preset pot bracket for JM, w/Screws
HK-44PCW	Preset control wheel, Black

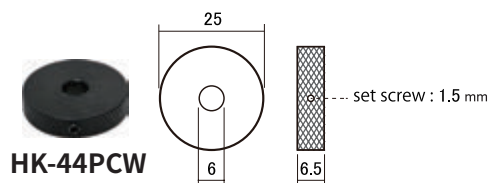

HK-44PCW

Truss Rod Covers



Screws are NOT included.

Item#	Shape	Color/Material
F-4007	Bell	Black 2-ply
DM-802	Triangle	Black 2-ply
DM-803	Bullet	Black 2-ply
DM-006	Bell	Maple
DM-008	Bell	Green Abalone
MRC-TRCB	Bell	Master Relic Collection Relic Black 2-ply



F-4007 DM-802 DM-803 DM-006 DM-008

Truss Rod Cover Screw

Round head. Size : 2.1mm x 10.0mm
MOQ : 100 pcs each



Item#	Finish
WS-02N	Nickel
WS-02G	Gold

Other Bass Parts

Finger Rest



For PB/JB type basses.
Screws included.

Item#	Description
F-REST	Plastic, Black
MRC-FREST	'51-'54, Maple, Black, Aged

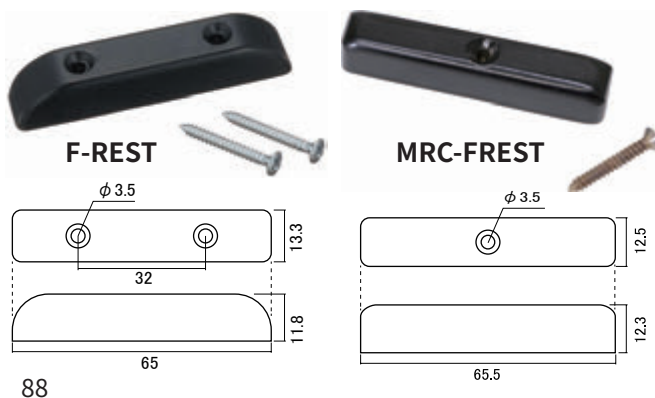

88

65.5

Endpins / Strap Buttons

Strap Buttons for Electric Guitars / Basses HOSCO Pack

Sold by a piece. (Not a pair)
Screw included.

Item#	Description
HK-13BS	Large type, Black
HK-13CS	Large type, Chrome
HK-13GS	Large type, Gold
HK-12NS	Fender® type, Nickel

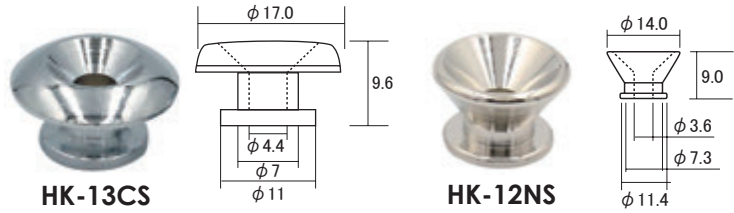

Felt Washer HOSCO Pack

Outer Diameter : 13.0 mm

Item#	Color
EP-FWBK	Black
EP-FWWH	White

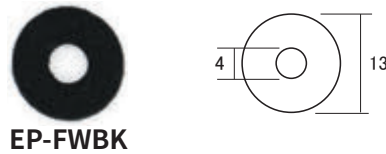

Endpins for Acoustic Guitars HOSCO Pack

Plastic Endpins



Item#	Pin Color	Dot (3mm)
F-0014	Cream	-
F-0015	Black	-
F-0016	White	-
F-0017	Cream	Black
F-0017A	Cream	Abalone
F-0018	Black	White
F-0018A	Black	Abalone
F-0019	White	Black
F-0019A	White	Abalone

Wooden Endpins



Item#	Wood	Dot (3mm)
F-0020	Ebony	-
F-0021	Ebony	MOP
F-0024	Rosewood	-
F-0025	Rosewood	MOP

Brass Endpin

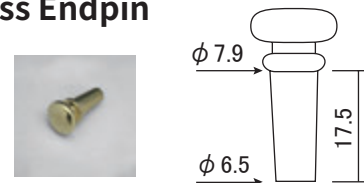

Item#	Material	Dot
F-0029	Brass	-

Plastic Bridge Pin / Endpin Assortment Set

Item#	Description
PIN-ASSORT	Plastic Bridge Pins Black x 36, White x 36, Cream x 36, Black w/dot x 60, White w/dot x 60, Cream w/dot x 60
	Endpins Black x 6, White x 6, Cream x 6 Black x 24, White x 24



PIN-ASSORT

Hardware

Guitar Hardware



String Bushings

Vintage style flush fit.
For TL and other non-tremolo guitars.
Fits HOSCO guitar bodies.
Diameter : 9.5mm
Sold by a piece. (HK-10) / a set of 6. (MRC-TLSBN)

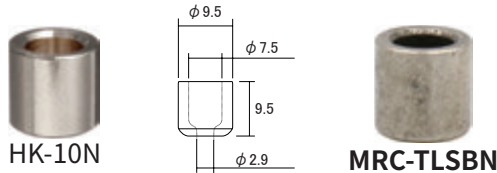

Item#	Finish
HK-10B	Black
HK-10G	Gold
HK-10N	Nickel
MRC-TLSBN	Aged Nickel, Master Relic Collection

String Retainer

Vintage Fender® type. For guitars.
Sold by a piece.
Screw included.

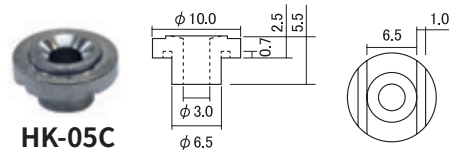

Item#	Finish
HK-05C	Chrome

Position Indicator

Used with Gibson® type knobs.
Sold by a piece. (HK-40) / a set of 4. (MRC-PTWN)



Item#	Description
HK-40	Nickel
HK-40G	Gold
MRC-PTWN	Aged Nickel, Master Relic Collection

Top Ferrules

For String-thru. Sold as a set of 6.



Item#	Finish
HK-TFB	Black
HK-TFC	Chrome
HK-TFG	Gold

Bass Hardware



String Bushings

Modern style flange fit. For electric basses.
Fits our TBD-**OP bass bodies.
Sold by a piece. (HK-09) / a set of 4. (MRC-OPBSBN)



Item#	Finish
HK-09B	Black
HK-09G	Gold
HK-09N	Nickel
MRC-OPBSBN	Aged Nickel, Master Relic Collection

String Retainer

Vintage Fender® type. For electric basses.
Sold by a piece.
Screw included.

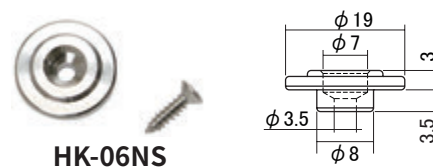

Item#	Finish
HK-06NS	Nickel

Bindings

Standard Celluloid and ABS plastic bindings are available. We actually have plenty of choices for pattern, thickness, and width. Contact us for further information.

Patterned Bindings

Material : Celluloid / MOQ : 100 pcs each

Item#	Pattern	Length	Thickness	Width	Note
F-CT6015	Tortoise	1,380	1.5	6	
F-WP6015	Pearloid	1,380	1.5	6	
F-5000	Ivoroid	1,380	1.5	6	Mesh-pattern
F-5000S	Ivoroid	1,380	1.5	6	Stripe-pattern
F-5003	Ivoroid	1,380	1.5	7	Mesh-pattern
F-5003S	Ivoroid	1,380	1.5	7	Stripe-pattern
F-5002	Ivoroid	1,380	1.5	10	Mesh-pattern
F-5002S	Ivoroid	1,380	1.5	10	Stripe-pattern



Tortoise



Pearloid



Ivoroid Mesh-pattern



Ivoroid Stripe-pattern

Plain Bindings

Material : ABS Plastic / MOQ : 100 pcs each

Item#	Color	Length	Thickness	Width
F-AB6015	Black	1,680	1.5	6
F-AI6015	Cream	1,680	1.5	6
F-AW6015	White	1,680	1.5	6
F-AB7015	Black	1,680	1.5	7
F-AI7015	Cream	1,680	1.5	7
F-AW7015	White	1,680	1.5	7
F-AB1015	Black	1,680	1.5	10
F-AI1015	Cream	1,680	1.5	10
F-AW1015	White	1,680	1.5	10



Black



Cream



White

Laminated Bindings

Popular laminated bindings.

Material : PVC plastic / MOQ : 100 pcs each

Item#	Color	Length	Thickness	Width
F-P1515BWB	BK/WH/BK	1,700	1.5	1.5
F-P1515WBW	WH/BK/WH	1,700	1.5	1.5
F-P1510BW	BK/WH	1,700	1.5	1.0
F-P6015BWB	BK/WH/BK	1,700	6.0	1.5
F-P6015WBW	WH/BK/WH	1,700	6.0	1.5
F-P6010BW	BK/WH	1,700	6.0	1.0

*BK : Black, WH : White



BWB



WBW



BW

Binding Glue

The super glue for our bindings is available. One package is enough for one guitar.

If there are oil, rubbish, and dust on an adhesion surface, please wipe off with solvent such as alcohol or acetone.

MOQ : 240 pcs



Expiration Date : 2-3 years

Please keep the glues in a dark and cool place.

Important Notice:

Because of the product's properties, this glue can be shipped by ocean freight only. Please confirm rules and regulations for import to your country before you order.

Item#	Description
H-BG20AL	Binding glue w/Aluminum packaging, 20 g

Purflings

Herringbone



143203D PB-0744D 151311H

Item#	Description
143203D	Rosette, 126mm inner dia., 1.5mm thick
PB-0744D	Pre-bent purfling for Dreadnought, 1.5mm thick, 2/SET
151311H	Back strip, 530(L) x 4.5(W) x 3.0(T) mm

Patterned Purflings

Both patterns are beautiful and these purflings will make your instruments fancier.

Material : Celluloid

Size : 1,400mm x 1.5mm x 1.5mm

MOQ : 100 pcs each



DM-701



DM-702

Item#	Pattern
DM-701	Abalone
DM-702	Pearloid

Inlays

Precut Fingerboard Inlays



Genuine Mother of Pearl and Green Abalone position marks for fingerboards.

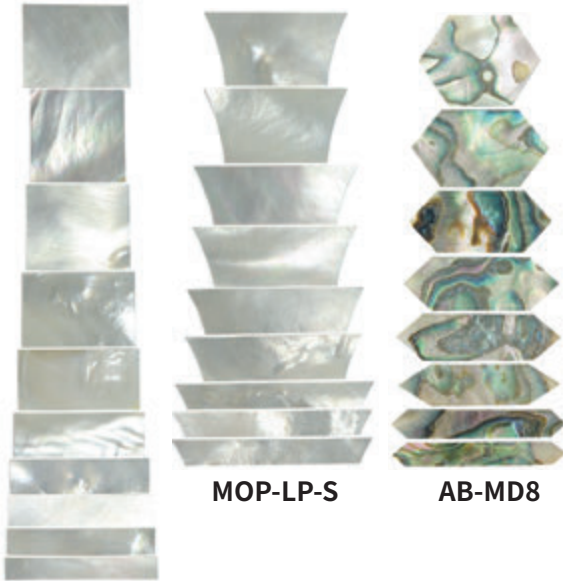

MOP-LP-S

AB-MD8

MOP-LP-C

Item#	Description
MOP-LP-C	MOP, Block type, 10/SET
MOP-LP-S	MOP, Crown type, 9/SET
AB-MD8	Green Abalone, 8/SET

Purfling Inlays



Genuine Green Abalone purfling inlays. Sold as a set of 15.



F-5030

F-5031
F-5031S

Item#	Shape	Size (L x W x T)
F-5030	Straight	25.0 x 1.6 x 1.6 mm
F-5031	Curved	25.0 x 1.6 x 1.6 mm
F-5031S	Curved	20.0 x 2.0 x 1.5 mm

Position Marks

Position Dots

Beautiful round position dots.
Thickness : 2.0 mm / MOQ : 100 pcs each



Mother of Pearl, Abalone, and Black-lip Pearl Oyster are genuine materials.

Item#	Description
MOP-2	2.0mm dia. Mother of Pearl
ABL-2	2.0mm dia. Abalone
BPO-2	2.0mm dia. Black-lip Pearl Oyster
DOT-IP-2.0	2.0mm dia. Acrylic White Pearl

Item#	Description
MOP-3	3.0mm dia. Mother of Pearl
ABL-3	3.0mm dia. Abalone
BPO-3	3.0mm dia. Black-lip Pearl Oyster
MOP-4	4.0mm dia. Mother of Pearl
ABL-4	4.0mm dia. Abalone
BPO-4	4.0mm dia. Black-lip Pearl Oyster
MOP-5	5.0mm dia. Mother of Pearl
ABL-5	5.0mm dia. Abalone
BPO-5	5.0mm dia. Black-lip Pearl Oyster
MOP-6	6.0mm dia. Mother of Pearl
ABL-6	6.0mm dia. Abalone
BPO-6	6.0mm dia. Black-lip Pearl Oyster
DOT-IP-6.0	6.0mm dia. Acrylic White Pearl

The specification of MOP-6 only will be changed once the current stock runs out.
In thickness : from 2.0mm to 1.8mm / In color of the backside : from current yellow to white as before

Side Dot Materials HOSCO Pack

Size : 200mm long x 2.0mm dia.
Material : Acety

Item#	Color
DOT-SIDE-B	Black
DOT-SIDE-W	White



Screws

Master Relic Collection Screw Set

ST type (Inch size) **HOSCO® Pack**



MRC-STSCW-SET

Item#	For
MRC-STSCW-SET	Pickups(Screws x 6, Spacers x 6), Jack cover(2), Back plate(6), Pickguard(8), Switch(2)

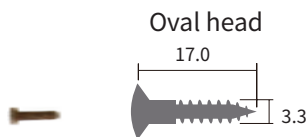
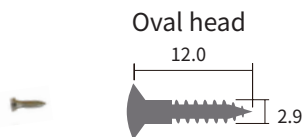

TL type (Inch size) **HOSCO® Pack**

Vintage '50s Blackguard TL type screw set. Slotted Head.



MRC-TLSCW-SET

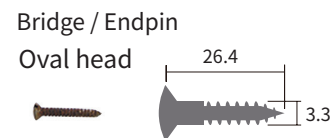
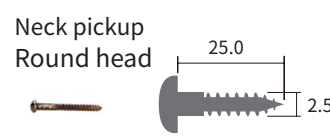
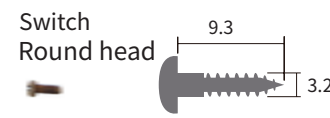
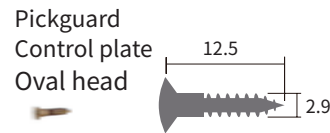
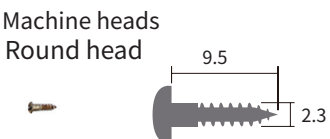
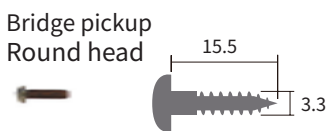
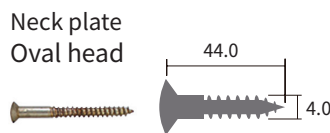

Item#	For
MRC-TLSCW-SET	Machine heads(7), Pickguard(5), Control plate(2), Switch(2), Bridge(4), Endpin(2), Neck plate(4), Neck pickup(Screws x 2, Spring x 2), Bridge pickup(Screws x 3, Spacers x 3),

ST/TL type Pickguard Screws



MRC-PGSCWN

MRC-PGSCWN-I

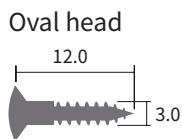

Item#	Description
MRC-PGSCWN	Aged Nickel, 100/SET
MRC-PGSCWN-I	Aged Nickel, Inch, 19/SET

LP type Mounting Ring Screws



MRC-MRSCWN

MRC-MRSCWNL

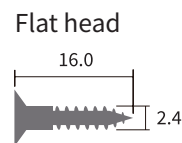
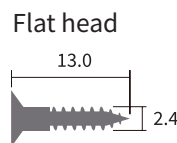

Item#	Description
MRC-MRSCWN	Aged Nickel, 100/SET
MRC-MRSCWNL	Aged Nickel, 100/SET

Bridge/Tremolo Mounting Screws



TS-02C

Oval head

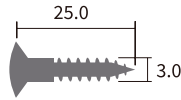

Item#	Finish
TS-02B	Black
TS-02C	Chrome
TS-02CK	Cosmo Black
TS-02G	Gold
TS-02N	Nickel

For GOTOH (Q'ty)
GTC101/102/12 (5)
510FX-6 (3), 510FX-7 (4)
201B-4 (5), 203B-4 (7)
CBB-4 (5), VTB-4 (5)



TS-04C

Flat head

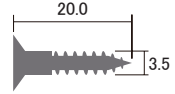

Item#	Finish
TS-04C	Chrome
TS-04G	Gold
TS-04N	Nickel

*Size will be changed to 3.0 x 20 mm.

For GOTOH (Q'ty)
WT3 (4)
BS-TC1/TI-TC1 (4)



TS-05C

Flat head

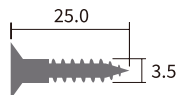

Item#	Finish
TS-05B	Black
TS-05C	Chrome
TS-05CK	Cosmo Black
TS-05G	Gold

For GOTOH (Q'ty)
303-4/6 (5), 404-4/6 (5)
303-5/404-5 (4)
S510B-4 (4), S510B-5 (5)
SLR (1)



TS-06C

Flat head

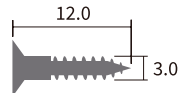

Item#	Finish
TS-06B	Black
TS-06C	Chrome
TS-06CK	Cosmo Black
TS-06G	Gold

For GOTOH (Q'ty)
J510-4/5 (2)
303-4/5/6 (2)
404-4/5/6 (2)



TS-08G

Flat head

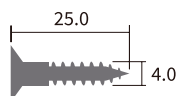

Item#	Finish
TS-08B	Black
TS-08C	Chrome
TS-08CK	Cosmo Black
TS-08G	Gold
TS-08N	Nickel

For GOTOH (Q'ty)
J510-4/5 (4)
205B-5 (5)



NS-01C

Oval head

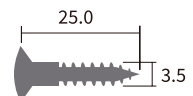

Item#	Finish
NS-01B	Black
NS-01C	Chrome
NS-01G	Gold

For HOSCO (Q'ty)
HK-21/22/23 (4)
HK-20 (5)
HK-41 (6), HK-47 (5)



WS-05N

Round head

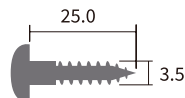

Item#	Finish
WS-05B	Black
WS-05C	Chrome
WS-05CK	Cosmo Black
WS-05G	Gold
WS-05N	Nickel

For GOTOH (Q'ty)
GE101T (6)
GE101TS (6)
VSVG (6)



WS-09C

Flat head

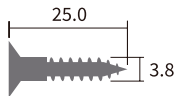

Item#	Finish
WS-09B	Black
WS-09C	Chrome
WS-09CK	Cosmo Black
WS-09G	Gold

For GOTOH (Q'ty)
GTC201/202 (4)

Mounting Ring Screws

 **PS08**

Item#	Finish
PS08B	Black
PS08C	Chrome
PS08G	Gold
PS08N	Nickel

Oval head

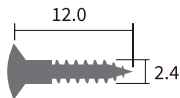

For HOSCO (Q'ty)
MR-F (4)
MRA-F (4)
MR-1F (4)
MRF-F (4)

 **PSH08**

Item#	Finish
PSH08B	Black
PSH08G	Gold
PSH08N	Nickel

Gibson® type
Flat head

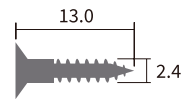

For HOSCO (Q'ty)
MR-F (4)
MRA-F (4)
MR-1F (4)
MRF-F (4)

 **PS09**

Item#	Finish
PS09B	Black
PS09C	Chrome
PS09G	Gold
PS09N	Nickel

Oval head

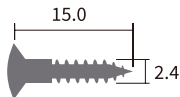

For HOSCO (Q'ty)
MR-R (4)
MRA-R (4)
MR-1R (4)
MRF-R (4)

 **PSH09**

Item#	Finish
PSH09B	Black
PSH09G	Gold
PSH09N	Nickel

Gibson® type
Flat head

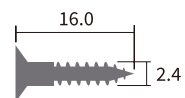

For HOSCO (Q'ty)
MR-R (4)
MRA-R (4)
MR-1R (4)
MRF-R (4)

Pickguard Screws



 **TS-01C**

Item#	Finish
TS-01B	Black
TS-01C	Chrome
TS-01CK	Cosmo Black
TS-01G	Gold
TS-01N	Nickel

Oval head

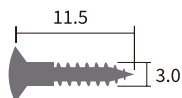

 **TS-11N**

Item#	Finish
TS-11B	Black
TS-11GD	Gold
TS-11N	Nickel

Oval head

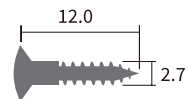

 **VSS-01N**

Item#	Finish
VSS-01B	Black
VSS-01C	Chrome
VSS-01G	Gold

Vintage style slotted screws.
Material : Steel
Oval head

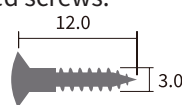

Item#	Finish
VSS-01N	Nickel
VSS-01UP	Unplated
MRC-PGVSSCWN	Aged Nickel, Master Relic Collection

Pickup Mounting Screws

 **PS10B**

Item#	Finish
PS10B	Black
PS10G	Gold
PS10N	Nickel

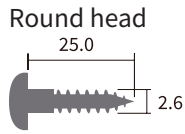

 **PS11B**

Item#	Finish
PS11B	Black
PS11G	Gold
PS11N	Nickel

For Humbuckers
Round head

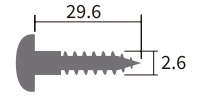

 **PS12B**

Item#	Finish
PS12B	Black
PS12G	Gold
PS12N	Nickel

For Bass pickups
Round head

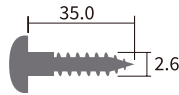

 **PS13B**

Item#	Finish
PS13B	Black
PS13G	Gold
PS13N	Nickel

Oval head

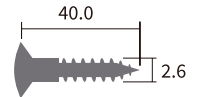

 **PS14B**

Item#	Finish
PS14B	Black
PS14G	Gold
PS14N	Nickel

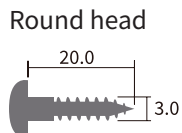

 **PS15B**

Item#	Finish
PS15B	Black
PS15G	Gold
PS15N	Nickel

For Single-coil pickups
Round head

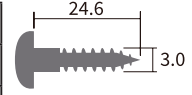

Plate/Cover Screws

 **NS-03C**

Item#	Finish
NS-03C	Chrome

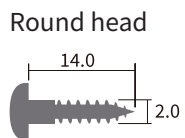

For HOSCO (Q'ty)
JP-20C (4)

 **TS-11N** HOSCO Pack

Item#	Finish
TS-11B	Black
TS-11GD	Gold
TS-11N	Nickel

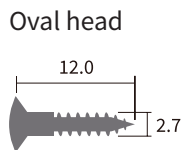

 **TS-01C** HOSCO Pack

Item#	Finish
TS-01B	Black
TS-01C	Chrome
TS-01CK	Cosmo Black
TS-01G	Gold
TS-01N	Nickel

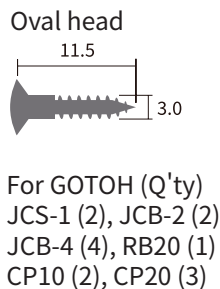

 **TS-03B** HOSCO Pack

Item#	Finish
TS-03B	Black
TS-03C	Chrome
TS-03CK	Cosmo Black
TS-03G	Gold
TS-03N	Nickel

For Neck plates
Oval head

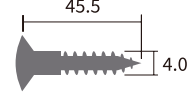

For GOTOH (Q'ty)
NBS-3 (4)
SPH (2)

Shorter screws for Neck plates
Suitable for slant necks!

	Item#	Finish
NEW	TS-03B-35	Black
NEW	TS-03C-35	Chrome
NEW	TS-03G-35	Gold
NEW	TS-03B-40	Black
NEW	TS-03C-40	Chrome
NEW	TS-03G-40	Gold

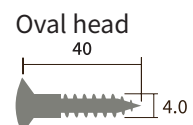
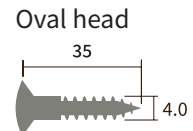

Endpin Screws

 **WS-04C**

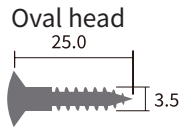

Item#	Finish
WS-04B	Black
WS-04C	Chrome
WS-04CK	Cosmo Black

Item#	Finish
WS-04G	Gold
WS-04N	Nickel

For GOTOH (Q'ty)
EP-A1 (1), EP-B1 (1)
EP-B2 (1), EP-B3 (1)

String Retainer Screws

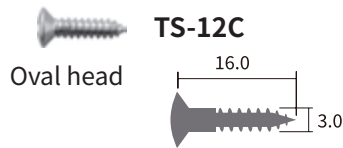

Item#	Finish
TS-12B	Black
TS-12C	Chrome
TS-12CK	Cosmo Black
TS-12G	Gold
TS-12N	Nickel

For GOTOH (Q'ty)
RB30 (1)

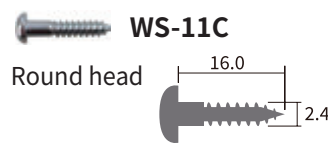

Item#	Finish
WS-11B	Black
WS-11C	Chrome
WS-11CK	Cosmo Black
WS-11G	Gold
WS-11N	Nickel

For GOTOH (Q'ty)
RG15 (1)
RG30 (1)
RG130 (1)

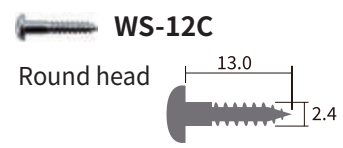

Item#	Finish
WS-12B	Black
WS-12C	Chrome
WS-12CK	Cosmo Black
WS-12G	Gold
WS-12N	Nickel

For GOTOH (Q'ty)
RG105 (1)

Tailpiece Screws

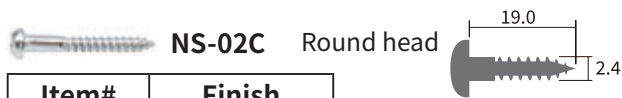

Item#	Finish
NS-02C	Chrome
NS-02G	Gold

For HOSCO (Q'ty)
SSG-6 (3), TP-EPH (3)
TP-135 (3), TP-175 (3)

Switch Mounting Screws

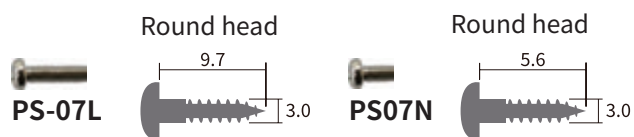
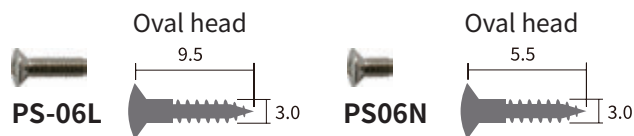

Item#	Finish
PS-06L	Nickel
PS06N	Nickel

Item#	Finish
PS-07L	Nickel
PS07N	Nickel

Truss Rod Cover Screws

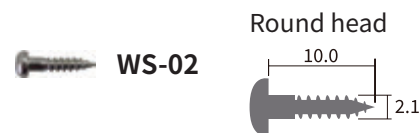

Item#	Finish
WS-02G	Gold
WS-02N	Nickel

Tuner Screws



WS-01G

Flat head

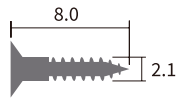

Item#	Finish
WS-01G	Gold

For GOTOH (Q'ty)
35G1600/1800 (8)
35G3600C (8)
40G2000 (8)



WS-02

Round head

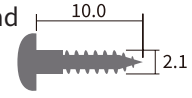

Item#	Finish
WS-02G	Gold
WS-02N	Nickel

For GOTOH (Q'ty)
35G (8), UK12 (8)
MA40/MF40 (10)
M120/M120S (10)



WS-03C

Round head

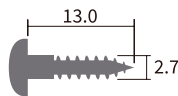

Item#	Finish
WS-03B	Black
WS-03C	Chrome
WS-03CK	Cosmo Black
WS-03G	Gold
WS-03N	Nickel

For GOTOH (Q'ty)
GB640/GBR640 (16)
CBT01 (16), FB30 (16)
GB528 (8), GB11W (12)
GB10 (16), GB2 (16)



WS-18C

Round head

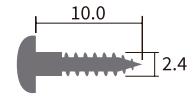

Item#	Finish
WS-18B	Black
WS-18C	Chrome
WS-18CK	Cosmo Black
WS-18G	Gold
WS-18N	Nickel

For GOTOH (Q'ty)
SG510/SG (6)
SE780 (12)
GB350/GB707 (4)



WS-19N



Round head

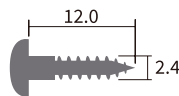

Item#	Finish
WS-19B	Black
WS-19CK	Cosmo Black
WS-19G	Gold
WS-19N	Nickel

For GOTOH (Q'ty)
SD510/SD90 (12)
SDS510/SD91 (7)



WS-21C

Round head

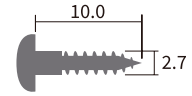

Item#	Finish
WS-21B	Black
WS-21C	Chrome
WS-21CK	Cosmo Black
WS-21G	Gold
WS-21N	Nickel

For GOTOH (Q'ty)
SXB510/SXN510 (12)
SE700/SE770 (12)
UK700 (8)



WS-22N

Oval head

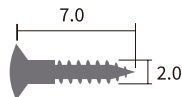

Item#	Finish
WS-22CK	Cosmo Black
WS-22G	Brass (Unplated)
WS-22N	Nickel

For GOTOH (Q'ty)
CXB01/CXN01 (12)
35G510/KG01 (8)
KG02 (12)



WS-23CK

Round head

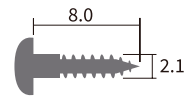

Item#	Finish
WS-23CK	Cosmo Black

For GOTOH (Q'ty)
ST31 6-string (12)
ST31 4-string (8)

Battery Box Screws



WS-10B

Oval head

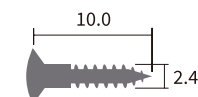

Item#	Finish
WS-10B	Black

For GOTOH (Q'ty)
BB-04/BB-04W (4)



TS-09B

Flat head

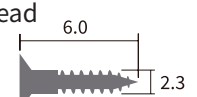

Item#	Finish
TS-09B	Black

For GOTOH (Q'ty)
BB-02 (2)

Wrenches

Allen Wrenches



Bulk Item# (w/o sleeve)	Bulk Item# (w/sleeve)	Size	For
WRE-1.27	WRE-1.27J	1.27mm (.050")	Saddle height adjustment on tremolo (Inch)
WRE-1.5	WRE-1.5J	1.5mm	Saddle height adjustment on tremolo (Metric)
WRE-1.57	WRE-1.57J	1.57mm (1/16")	Bass saddles, JB knobs (Inch)
WRE-2.0	WRE-2.0J	2.0mm	GOTOH® VS100N saddles, knobs
WRE-2.5	WRE-2.5J	2.5mm	Floyd Rose® saddle fixing screws
WRE-3.0	WRE-3.0J	3.0mm	Floyd Rose® stud height adjustment
WRE-4.0	WRE-4.0J	4.0mm	Truss rod nut
WRE-5.0	WRE-5.0J	5.0mm	Truss rod nut



Wrenches w/sleeves



WRE-2.0

Truss Rod Wrenches



Bulk Item# (w/o sleeve)	Bulk Item# (w/sleeve)	Size
WRE-4.0	WRE-4.0J	4.0mm
WRE-5.0	WRE-5.0J	5.0mm
WRE-7.0	WRE-7.0J	7.0mm
WRE-8.0	WRE-8.0J	8.0mm
WRE-I14	WRE-I14J	1/4"
WRE-I516	WRE-I516J	5/16"
N/A	H-TRW+	for Slotted



WRE-4.0



WRE-5.0



WRE-8.0



WRE-I14



WRE-I516 w/screwdriver



H-TRW+



Resonator Guitar Parts

Resonator Guitar Bridges

Spider Bridge

Aluminum spider bridge by sand casting.

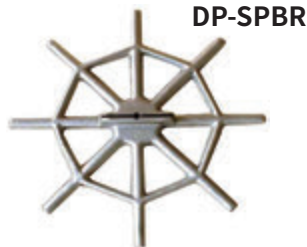

Item#	Description
DP-SPBR	Spider bridge

Biscuit Bridge

Black-colored wooden bridge with a slot for saddle.
Diameter : 60.5mm / Thickness : 8.0 mm



Item#	Description
DP-BCBR	Biscuit bridge

Resonator Cones

Resonator Cone for Spider Bridge

Material : Aluminum



Item#	Description
DP-SPRC	For Spider bridge, 10.5"

Resonator Cone for Biscuit Bridge

Material : Aluminum



Item#	Description
DP-BCRC	For Biscuit bridge, 9.5"

Coverplate

Coverplate for Spider Bridge

Heavy duty coverplate made of steel.
Nickel-plated.

Item#	Description
DP-SPCP	For Spider bridge, 11.5"

DP-SPCP



Extension Nut

HOSCO[®]
Pack

Fits over the existing string nut for instantly switch to a lap steel. Nickel-plated.
String spacing : 43.66mm (8.73mm x 5) = 23/32" (11/32" x 5)
Length : 48.0 mm
Material : Steel

Item#	Description
F-3303	Extension nut



F-3303

Saddles

Spider Bridge Saddle



Item#	Description
DP-SPSD	Spider bridge saddle, 2/SET

Biscuit Bridge Saddle



Item#	Description
DP-BCSD	Biscuit bridge saddle, Maple, Blank

Sound Ring

Diameter : 58.0mm (Outside) / 47.5mm (Inside)
Sold by a piece. (Not a pair)



Item#	Finish
DP-SR	Chrome

Resonator Guitar Tailpiece

Traditional resonator guitar tailpiece.
Material : Steel



Item#	Finish
DP-TP	Chrome

Resonator Guitar Machine Heads



3-on-Plate Machine Heads

Vintage style 3-on-plate machine heads with white buttons for slotted peghead.
Gear ratio = 1:15
Screws included.

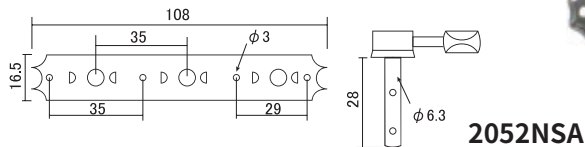

2052NSA



Item#	Finish	Note
2052NSA	Nickel	For Slotted peghead

Banjo Parts

Banjo Armrests

Single Leg Armrest

Gibson® type single leg armrest. Nickel-plated.
Material : Brass

Item#	Description
BP-ARSL	Single leg armrest



Prewar Vega® type Armrest

Can be used with a 24 or 28 bracket banjo. Nickel-plated.
Material : Brass

Item#	Description
BP-ARVG	Prewar Vega® type



Banjo Bracket Wrenches

T-shaped hex wrenches for adjusting the tension of banjo heads. Nickel-plated.
Material : Brass

Item#	For
BP-WR65	6.5mm (1/4") hex nuts
BP-WR70	7.0mm hex nuts
BP-WR72	7.2mm (9/32") hex nuts
BP-WR80	8.0mm (5/16") hex nuts



Banjo Bridge

Item#	Description
GB-1-5/8	5/8" high, Straight, Maple/Ebony



Banjo Hook / Nut Set

4mm diameter hooks in 65mm long with 1/4" (6.35mm) hex nuts. Nickel-plated.
Sold as a set of 24.

Item#	Description
BP-BHN24	Banjo hook/nut set, 24/SET



Banjo Tailpieces

Wide range of banjo tailpieces are available. Nickel-plated.

Item#	Description
BP-TPNO	Non-adjustable type
BP-TPWV	Waverly type
BP-TPKS	Kershner type



Item#	Description
BP-TPNK	No Knot type
BP-TPOW	Old Waverly type
BP-TPPRC	Old Presto type
BP-THL	Prewar reissue, L-Tailpiece Holder

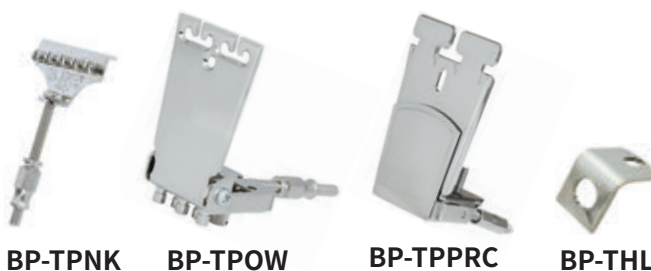

Blank Bone Nut



Item#	Size (L x H x T) mm
M-502	37 x 8 x 5

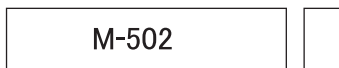

M-502

Coordinator Rod Set

Dual rim rod set with a long nut for easier adjustment. Hardware included.

Item#	Description
BP-CR	Coordinator rod set



Electronics

Parts

Other String Instrument Parts

Accessories

Maintenance

Relic Parts

Resonator Flange / Tube

One piece flange plate for standard 24 bracket hook spacing.
Nickel-plated.
Should be used with BP-FGT tube. Sold separately.

Item#	Description
BP-FG	Resonator flange plate, Nickel
BP-FGT	Tube for flange plate (BP-FG)

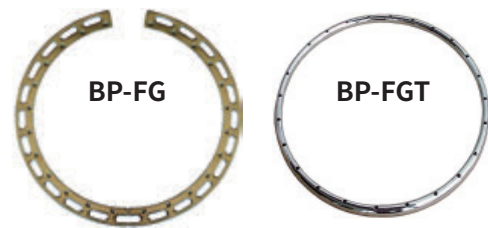

Fits our BP-FG
flange plate.

Resonator Hardware Sets

For attaching resonators to banjos.
Both sets come with 4 each of wall lugs, thumbscrews, and brackets.
Bracket screws are NOT included.

Item#	Description
BP-RHL	L-shaped brackets
BP-RHT	T-shaped brackets

BP-RHL



BP-RHT 30s reissue



Tension Hoop

Tension hoop for 11" diameter banjo rim. Standard 24 notches. Nickel-plated.
Material : Zinc

Item#	Description
BP-THN	Notched tension hoop for 11" rim



BP-THN

Mandolin Parts

Blank Bone Nut



M-502



M-502

Item#	Size (L x H x T) mm
M-502	37 x 8 x 5

Mandolin Tailpieces

Material : Stainless steel
Screws included.

Item#	Finish
M-131	Nickel
M-132	Gold



M-131

Mandolin Bridges



M-202

Item#	Wood	Hardware
M-201	Ebony	Nickel
M-202	Ebony	Gold

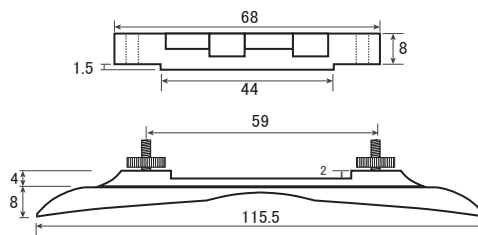

Mandolin Pickguards

Large-sized pickguards with white & black bindings. Bracket included.

A-model Pickguards

B-1A



Item#	Model	Pickguard	Bracket
B-1A	A	Black	Nickel
B-1A/G	A	Black	Gold

F-model Pickguards

B-2F



Item#	Model	Pickguard	Bracket
B-2F	F	Black	Nickel
B-2F/G	F	Black	Gold

Mandolin Pickguard Bracket Set

Comes with ebony block for gluing to the backside of the pickguard. Screw included.

Item#	Finish
MB-N	Nickel
MB-G	Gold



Ukulele Parts

Blank Bone Nut

HOSCO[®]
Pack

Item#	Size (L x H x T) mm
M-502	37 x 8 x 5

M-502



M-502

Kerfed Linings

These linings have a veneer on the back side. They are very flexible and easy to handle.

Item#	Size	Set
KL3-UK-MA	500 x 10 x 4mm	Mahogany x 2



KL3-UK-MA

Violin Parts

Item#	Description
VP-CR1E	Chinrest w/Clamp, Dresden type, Ebony
VP-EP1E	Endpin, Standard, Ebony
VP-FG1E	Fingerboard, 4/4, Shaped, Ebony
VP-NT1E	Nut, Pre-shaped, Ebony
VP-PG1E	Peg, Standard 4/4, Ebony
VP-SD1E	Saddle, Pre-shaped, Ebony
VP-14	String adjuster, Nickel
VP-TP1E	Tailpiece, Standard 4/4, Ebony
VP-TH1G	Tailpiece fastener



Picks

Thumb Picks

Order picks with your logo! OEM production is available.
 Please send us your logo in Illustrator format. Then we will send you a quote soon.
 There are a lot of other colors besides the ones below. Contact us for further information.

Sold per dozen

Item#	Size	Color
GP-5	Medium	Pearloid
GP-6	Large	Pearloid
GP-7	Large	Multicolor
GP-8	Ex-Large	Pearloid
GP-9	Large	Tortoise
GP-10	Large	Ivoroid
GP-11	Medium	Ivoroid
GP-12	Small	Ivoroid

Sold per 50 pcs/bag

Item#	Size	Color
T202MT	Medium	Tortoise
T202MS	Medium	Shell
T202MW	Medium	White
T202MB	Medium	Black
T200LT	Large	Tortoise
T200LS	Large	Shell
T200LW	Large	White
T200LB	Large	Black



T-202M



T-200L

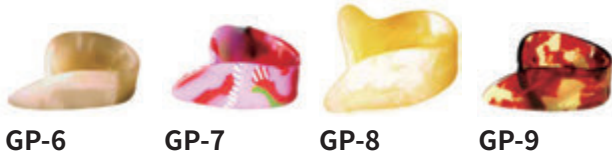

GP-6

GP-7

GP-8

GP-9

Ultem Thumb Picks

This material "Ultem" is used to many fields like medical care, science, and so on. Also, the Ultem is known as a similar material as a nail. These picks make clear sound like the one by tortoiseshell picks.
 MOQ : 1,000 pcs per each model

Item#	Size
UL-TM	Medium
UL-TL	Large



UL-T

Finger Picks

Sold per 50 pcs/bag

Item#	Size	Color
F301MT	Medium	Tortoise
F301MS	Medium	Shell
F301MW	Medium	White
F301MB	Medium	Black
F300LT	Large	Tortoise
F300LS	Large	Shell
F300LW	Large	White
F300LB	Large	Black



F301M

F300L

Flat Picks

Ultem Flat Picks

This material "Ultem" is used to many fields like medical care, science, and so on. Also, the Ultem is known as a similar material as a nail. These picks make clear sound like the one by tortoiseshell picks.
MOQ : 1,000 pcs per each model



UL-TRI



UL-TD



UL-JZ

Item#	Description	Item#	Description	Item#	Description
UL-TRI0.6	Triangle, 0.6mm	UL-TD0.6	Tear-drop, 0.6mm	UL-JZ0.88	Jazz, 0.88mm
UL-TRI0.8	Triangle, 0.8mm	UL-TD0.8	Tear-drop, 0.8mm	UL-JZ1.0	Jazz, 1.0mm
UL-TRI1.0	Triangle, 1.0mm	UL-TD1.0	Tear-drop, 1.0mm	UL-JZ1.2	Jazz, 1.2mm

Standard Flat Picks

Thin Thickness : 0.5mm

Item#	Shape	Color
1TT	No.1	Tortoise
1TS	No.1	Shell
1TW	No.1	White
1TB	No.1	Black

Medium Thickness : 0.75mm

Item#	Shape	Color
1MT	No.1	Tortoise
1MS	No.1	Shell
1MW	No.1	White
1MB	No.1	Black

Heavy Thickness : 1.0mm

Item#	Shape	Color
1HT	No.1	Tortoise
1HS	No.1	Shell
1HW	No.1	White
1HB	No.1	Black



No.1

Thin Thickness : 0.5mm

Item#	Shape	Color
4TT	No.4	Tortoise
4TS	No.4	Shell
4TW	No.4	White
4TB	No.4	Black

Medium Thickness : 0.75mm

Item#	Shape	Color
4MT	No.4	Tortoise
4MS	No.4	Shell
4MW	No.4	White
4MB	No.4	Black

Heavy Thickness : 1.0mm

Item#	Shape	Color
4HT	No.4	Tortoise
4HS	No.4	Shell
4HW	No.4	White
4HB	No.4	Black



No.4

Thin Thickness : 0.5mm

Item#	Shape	Color
6TT	No.6	Tortoise
6TS	No.6	Shell
6TW	No.6	White
6TB	No.6	Black

Medium Thickness : 0.75mm

Item#	Shape	Color
6MT	No.6	Tortoise
6MS	No.6	Shell
6MW	No.6	White
6MB	No.6	Black

Heavy Thickness : 1.0mm

Item#	Shape	Color
6HT	No.6	Tortoise
6HS	No.6	Shell
6HW	No.6	White
6HB	No.6	Black



No.6

Thin Thickness : 0.5mm

Item#	Shape	Color
9TT	No.9	Tortoise
9TS	No.9	Shell
9TW	No.9	White
9TB	No.9	Black

Medium Thickness : 0.75mm

Item#	Shape	Color
9MT	No.9	Tortoise
9MS	No.9	Shell
9MW	No.9	White
9MB	No.9	Black

Heavy Thickness : 1.0mm

Item#	Shape	Color
9HT	No.9	Tortoise
9HS	No.9	Shell
9HW	No.9	White
9HB	No.9	Black



No.9

Sand Grip Picks

MOQ : 1,000 pcs per each model

Item#	Shape	Size
1SPT	No.1	Thin
1SPM	No.1	Medium
1SPH	No.1	Heavy



1SP

6SPT	No.6	Thin
6SPM	No.6	Medium
6SPH	No.6	Heavy



6SP



Surface of Sand Grip

Rubber Grip Picks

MOQ : 1,000 pcs per each model

Item#	Shape	Size
1RPT	No.1	Thin
1RPM	No.1	Medium
1RPH	No.1	Heavy



1RP

6RPT	No.6	Thin
6RPM	No.6	Medium
6RPH	No.6	Heavy



6RP



Surface of Rubber Grip

Mandolin Picks

Thickness : 1.5 mm

Sold per dozen

Item#	Color
MP-10	Black
MP-11	White
MP-12	Tortoise
MP-13	Assortment color
MP-14	Multicolor



MP-12

Mutes

MyMute™

The new innovation of Violin and Cello Mutes. MyMute™ is newly designed and very easy to secure hold on its bridges with the original clamping system (Patent Pending). Suitable for 3/4 and 4/4 size. Material : Brass / Finish : Gold

Item#	For	Weight
MM-V	Violin / Viola	65g
MM-C	Cello	260g



The thumbscrew on top prevents falling off.



MM-V



MM-C

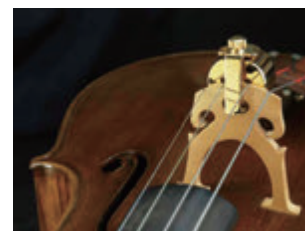

Violin Mute

Item#	Description
VP-MT1E	Mute, Ebony



VP-MT1E

Capo

Banjo 5th Capo

Sliding 5th banjo capo. Screws included,

Item#	Description
BC-5B	Banjo capo for 5th string <While stock lasts>



BC-5B

Slide Bars

Stevens Steel Bars

Popular shape for resonator guitar players. Made by GOTOH. Chrome is better than Nickel for sensitive skin. Length : 72mm / Weight : 143g / Material : Brass While stock lasts

Item#	Finish
DA-SSBN	Nickel
DA-SSBC	Chrome



DA-SSBN

Care / Cleaning

Wiping Cloths

HOSCO Ezo-deer Chamois cloth Made in Japan

This chamois leather is made of Ezo-deer Chamois captured as a forest protection measure in Hokkaido. We have begun to introduce this environmentally friendly product overseas in addition to its domestic release in Japan.

Ezo-deer Chamois is chamois-tanned wild deer leather. Therefore, there may be scratches or holes left on the product from fights, but this is a sign of authenticity and does not affect the quality.

<Ezo-deer Chamois story>

More than 100,000 Ezo-deer are captured annually due to population adjustments in Hokkaido's Ezo-deer conservation management plan. It is true that the use of wild animal resources can lead to overhunting if not done carefully, but since they are captured with adjustments, the disposal of parts other than meat after mass capture is more problematic than such concerns at this time, and not using them is far more pitiful than refraining from using them.

The fiber structure of Ezo-deer skin was not as good as that of other deer family. Therefore, we introduced the deerskin "nameshi" technique, a traditional industry in Nara, and after repeated trial and error, we brought out the thin and soft texture of Ezo deer skin and "Ezo-Deer Chamois" was born.



HCL-100S

	Item#	Size
NEW	HCL-100S	Small / 30 x 30cm
NEW	HCL-150M	Medium / 35 x 40cm

Professional Care Cloth for superior finish

Quality care cloth for professional luthiers and musical instrument lovers.
 Best suited for removing dusts, fingerprints, cleansing chemical and compound.
 Anti-static feature never misses dusts.
 Thick ultra-fine microfiber has both flexibility and durability.
 Versatile in both dry and wet use.

Item#	Size
HWC-3739	37 x 39 cm



HOW TO USE



HWC-3739



Packaging

Easy Fret Care

Easy Fret Care includes 2 x Fret Care Cloth and 5 x Fret Care Sheet with Aluminum case

Case size : 93 x 60 x 5mm

Easy Care Cloth size : 90 x 55mm

Easy Care Sheet size : 91 x 55mm (16/18/21mm)

Easy Care Sheet slit length : 65mm



H-EFC-S20

Easy Fret Care, 2.0mm
(for Small size fret)

H-EFC-S24

Easy Fret Care, 2.4mm
(for Medium size fret)

H-EFC-S28

Easy Fret Care, 2.8mm
(for Jumbo size fret)



H-EFC-R20

Easy Fret Care, 2.0mm Refill Pack, w/o case

H-EFC-R24

Easy Fret Care, 2.4mm Refill Pack, w/o case

H-EFC-R28

Easy Fret Care, 2.8mm Refill Pack, w/o case

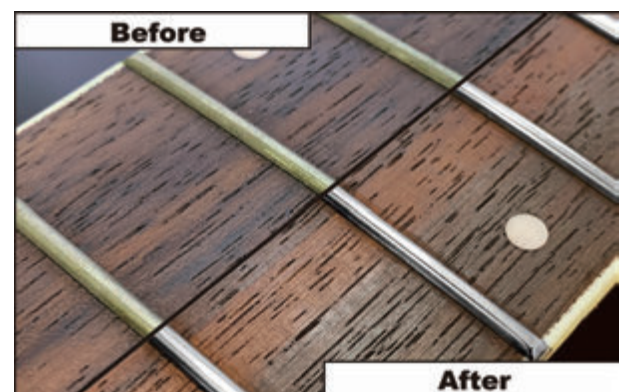

<How to use>

1. Please wipe the fingerboard and remove the dusts by common cloth first.
2. Take a piece of care sheet and put it to cover the fingerboard to show the fret.
3. Polish the fret by care cloth.
4. When polished it, remove the care sheet and put it on the next fret.
5. Polish the next fret in the same way.
6. When you feel the care sheet glue gets weak, please change to a new one.



HOW TO USE

Humidity Controllers

HOSCO®
Pack

Fret Shield **A.A.A.**

The Fret Shield can prevent strings from scratching frets and also absorb humidity inside of the case. Just put it between strings and fingerboard.

Strong Points

- 1) Prevents strings from scratching frets.
- 2) Controls humidity properly.
- 3) Odor eliminating effect and mildew-proof
- 4) Made in Japan

Material : Polypropylene (Exterior) / Silica gel Type B (Interior)

Item#	Size	For
AHM-660	600 x 60 mm	Guitars / Basses
AHM-530	300 x 50 mm	Ukuleles / Mandolins



AHM-530
(300mm long)



AHM-660
(600mm long)



HOW TO USE

Hygro-Thermometers

HOSCO Hygro-Thermometers HOSCO Pack

Our Hygrometer / Thermometer is useful as just as the indicator, also it is the best tool to monitor your instrument if you mount in your guitar case with our optional mount kit.

Also, the H-HT60/L can be used as an interior parts of your workshop.

Features :

- * Japanese high quality mechanism, called EX sensor installed.
- * Tolerance : $\pm 3\%$ for hygrometer and ± 2 degree for Thermometer.
- * 62mm outer diameter x 19mm thickness.
- * Black face design fits for guitar case or musician's room.
- * Fahrenheit thermometer is also available.
- * Made in Japan
- * Easy to install into most of wooden guitar case with our case mount kit.
(No damage to the case!, but not sure if you can use for any kind of cases, you need to check your case first.)



H-HT60



H-HT60F

Item#	Description
H-HT60	HOSCO Hygro-Thermometer, Celsius
H-HT60F	Fahrenheit version

With Leather Frame



H-HT60/L



Stand style



Wall Hanger style

Item#	Description
H-HT60/L	H-HT60 w/Leather frame

With Case Mount Kit



H-HT60/M



HT-MKIT

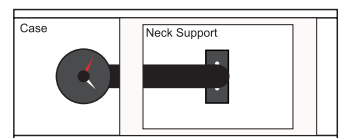
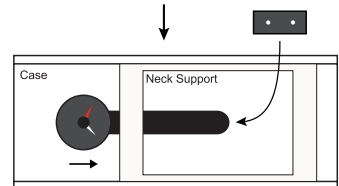
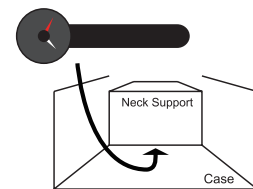

Item#	Description
H-HT60/M	H-HT60 w/Case mount kit
HT-MKIT	Case mount kit Only

Master Relic Collection

ST type Parts



Pickguards



Yellowed surface worn and buffed to aged look, with dirt buildup on screw holes, worn marks on under string areas with slightly rounded edges.
(MRC-ST57W1)

MRC-ST57W1



Worn truss rod scope, superficial crack lines, discolored surface buffed to aged look with dirt buildup on screw holes, worn marks on under string areas with slightly rounded edges.
(MRC-ST63MI3)

MRC-ST63MI3

Item#	Color (Mounting holes)
MRC-ST57W1	Relic Vintage White 1-ply (8)

Item#	Color (Mounting holes)
MRC-ST63MI3	Relic Mint Cream 3-ply (11)

Control Knob Sets



Round edges with buffed surface on knobs with dirt buildup on the sides and darkish brown fonts, Based on White.
(MRC-STKN50W-SET)

MRC-STKN50W-SET



Dirt buildup on the sides of knobs, finely worn lines on surface and oxidized green fonts, Based on Parchment White.
(MRC-STKN60W-SET)

MRC-STKN60W-SET

Item#	Description
MRC-STKN50W-SET	50s, Relic White, 3/SET (Vx1/Tx2)
MRC-STKN60W-SET	60s, Relic Parchment White, 3/SET (Vx1/Tx2)

Arm/Switch Knob Set

Medium aged. Based on Parchment White. The arm knob has 5mm diameter hole and the switch knob fits U.S. made switches. Sold in pair.

MRC-STASW-SET



Item#	Color
MRC-STASW-SET	Relic Parchment White

Screw Set (Inch size)



MRC-STSCW-SET



Item#	For
MRC-STSCW-SET	Pickups(Screws x 6 , Spacers x 6), Jack cover(2), Back plate(6), Pickguard(8), Switch(2)

ST type Parts



Pickup Cover Sets

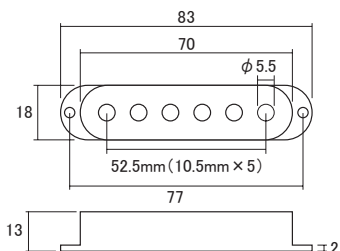

MRC-STPC50W-SET

MRC-STPC60W-SET

Item#	Description
MRC-STPC50W-SET	50s, Relic White, 3/SET

Item#	Description
MRC-STPC60W-SET	60s, Relic Parchment WH, 3/SET

Round edges with buffed surface and dirt trapped in gaps on the side and screw mounting areas. Bases on White. (MRC-STPC50W-SET)

Worn surface with finely worn lines and dirt trapped in gaps on the side and screw mounting areas. Based on Parchment White. (MRC-STPC60W-SET)

TL type Parts



Pickguards



Yellowed surface worn and buffed to aged look, dirt buildup on screw holes, worn marks on under string areas with slightly rounded edges. (MRC-TL60W1)

Nitro Cellulose lacquer on front side, aged with dirt and irregular wears on surface and shadowed marks under string area. This even has a 5" tin can mark on the rear as found on most 1950s blackguard guitar pickguards. (MRC-TLBL)



MRC-TL60W1

MRC-TLBL

Item#	Color (Mounting holes)
MRC-TL60W1	Relic Vintage White 1-ply (8)

Item#	Color (Mounting holes)
MRC-TLBL	Relic Black (Bakelite) 1-ply (5)

Pickup Cover

Worn surface with faint shadow marks left from the strings. All tastefully done with no exaggeration.

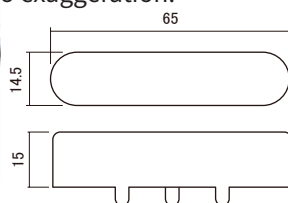

MRC-TLPCN

Item#	Description
MRC-TLPCN	Neck position, Aged Nickel

String Bushings

Vintage style flush fit. For TL and other non-tremolo guitars. Fits HOSCO guitar bodies. Diameter : 9.5mm Sold by a set of 6.

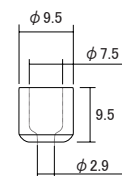

MRC-TLSBN

Item#	Description
MRC-TLSBN	Aged Nickel, 6/SET

Jack Cover

Comes with a retainer clip.

Item#	Finish
MRC-TLJCC	Aged Chrome

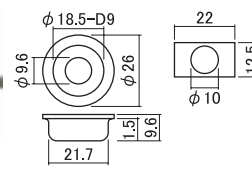

MRC-TLJCC

TL type Screw Set (Inch size) HOSCO[®] Pack



MRC-TLSCW-SET

Vintage 50s Blackguard TL type screw set. Slotted Head.

Item#	For
MRC-TLSCW-SET	Machine heads(7), Pickguard(5), Control plate(2), Switch(2), Bridge(4), Endpin(2), Neck plate(4), Neck pickup(Screws x 2, Spring x 2), Bridge pickup(Screws x 3, Spacers x 3),

ST/TL type Parts

Pickguard Screws

Item#	Description
MRC-PGSCWN	Aged Nickel, 3.0x12.0mm, 100/SET
MRC-PGSCWN-I	Aged Nickel, Inch, 19/SET
NEW MRC-PGVSSCWN	Aged Nickel, Slotted, 3.0x12.0mm, 100/SET

Oval head

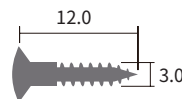

MRC-PGSCWN

LP type Parts HOSCO[®] Pack

Pickguard

Discolored surface with finely worn marks and features marks, with dirt buildup on screw holes.

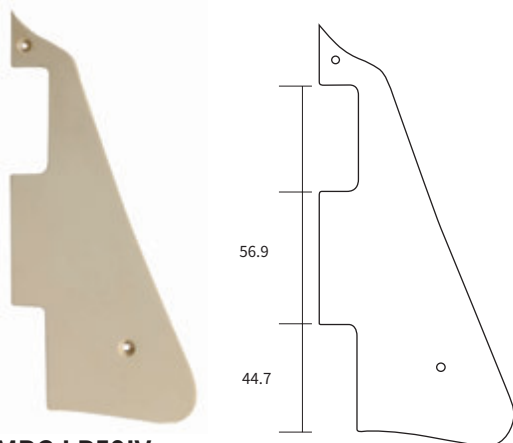

MRC-LP59IV

Item#	Description
MRC-LP59IV	'59, Relic Cream 1-ply

Pickguard Bracket

Screws, bolt, nut, & washer included.



MRC-LPBRC

Item#	Finish
MRC-LPBRC	Aged Chrome

Position Indicator

Item#	Description
MRC-PTWN	Aged Nickel, 4/SET



MRC-PTWN

Mounting Ring Screws

MRC-MRSCWN MRC-MRSCWNL

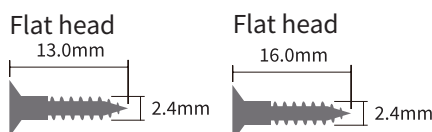

Item#	Description
MRC-MRSCWN	Aged Nickel, 100/SET
MRC-MRSCWNL	Aged Nickel, 100/SET

Truss Rod Cover



MRC-TRCB

Item#	Color
MRC-TRCB	Relic Black/White 2-ply

LP type Parts



Pickup Cover Set

Shallow dimple on the polepiece holes, worn surface with faint shadow marks left from the strings.

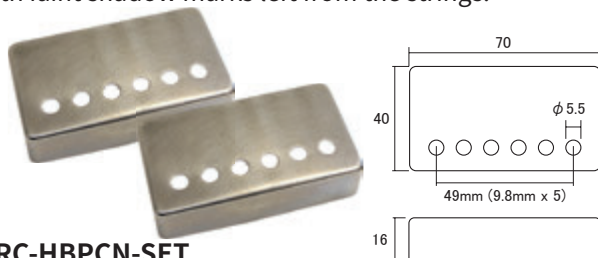

MRC-HBPCN-SET

Item#	Description
MRC-HBPCN-SET	Aged Nickel, 2/SET

Jack Plate

Discolored surface with finely worn marks and features marks left by the Switchcraft® jacks on the front and rear.

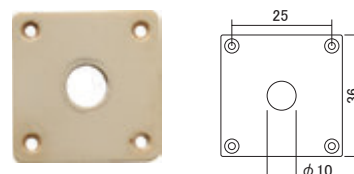

MRC-LPJCIV

Item#	Color
MRC-LPJCIV	Relic Cream

PB type Parts



Pickguards

These are coated with nitrocellulose lacquer with a 5" can mark on the rear of the pickguard. Contrast marks on the under strings area. Each piece is aged uniquely and at the right areas. Made with correct template from the 50s era.

Material : Bakelite

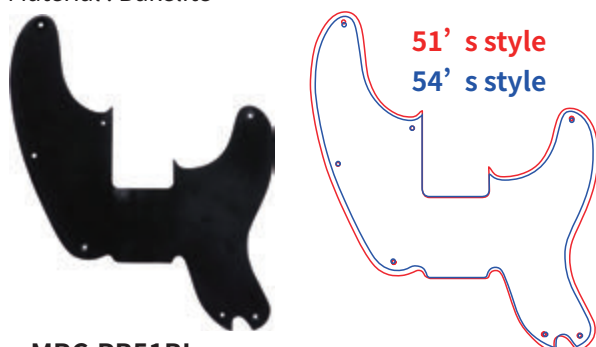

MRC-PB51BL

Item#	Description
MRC-PB51BL	'51, Relic Black
MRC-PB54BL	'54, Relic Black

Finger Rest

51 P Bass Thumb Rest "Tug Bar". Made with solid maple wood and finished with nitrocellulose lacquer. Light subtle natural wears. Single screw hole, just like how it was in the 50s.

Material : Maple
Screw included.

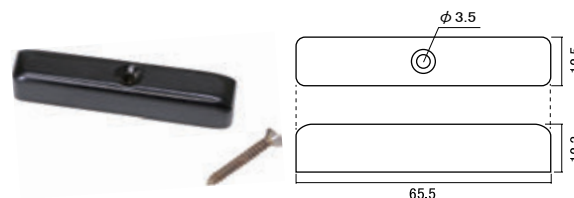

MRC-FREST

Item#	Description
MRC-FREST	'51-'54, Relic Black

String Bushings

Fits our TBD-**OP bass bodies.
Sold by a set of 4.

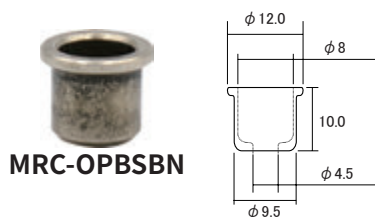

MRC-OPBSBN

Item#	Description
MRC-OPBSBN	Aged Nickel, 4/SET

HOSCO[®]

The specifications and prices are subject to change without notice.

20230509