

**HOSCO®**

**Luthier  
Tools  
Catalog**

**2023-2024**

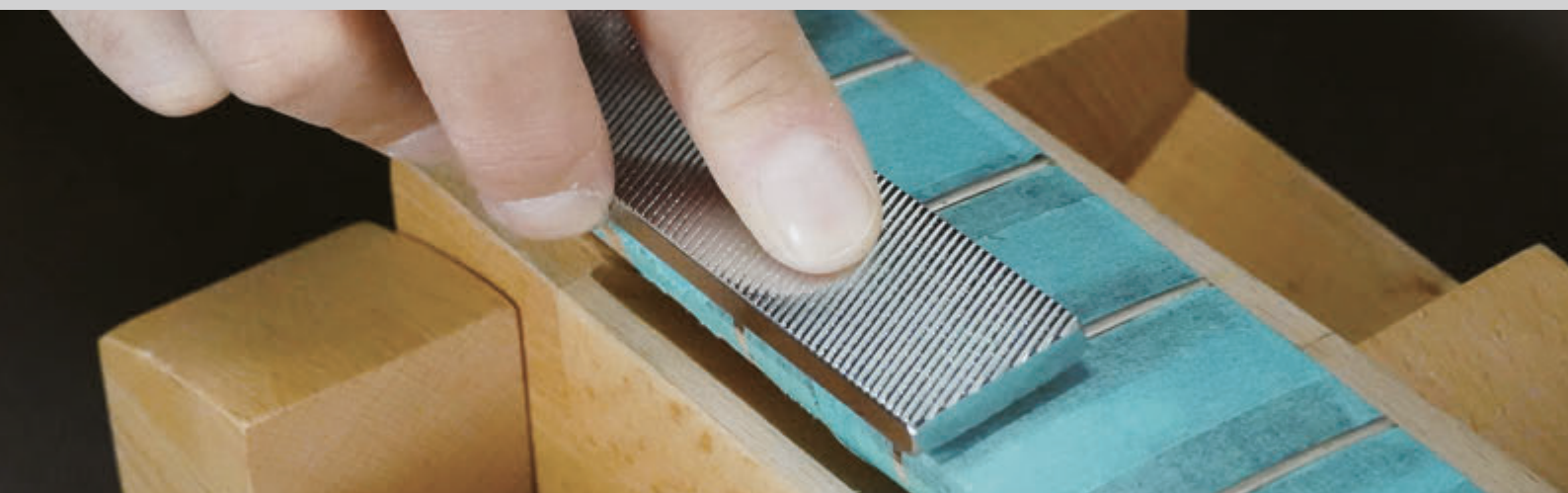



***HOSCO***<sup>®</sup>

***Luthier Tools***

**Catalog 2023-2024**



## INDEX

### Nut & Saddle work



HOSCO Nut Work Table .....	6
Nut and Saddle Shaping Files .....	6
String Guide Saw .....	7
GrooBar™ -Nut Slot Assist Tools-.....	7
Black Nut Files .....	8
Diamond-combo Black Nut Files .....	9
Line Round Files .....	9
Double Edge Nut Files.....	10
Edge-Cut Nut Files .....	10
Saddle Slot Files .....	11



### Head & Fingerboard work



Step Drill Bits.....	12
Jewelers Saws .....	13
Super Q Jewelers Saw Handle.....	13
Jewelers Saw Super Q Blades .....	13
Fret Slot Cutting Saws.....	14
Fret Slot Cleaning Saws .....	14
Fret Slot Saw Guide .....	15
Low Tack Masking Tapes .....	16
Sanding Materials .....	16
Kovax Rolled Sandpapers .....	16
Self-adhesive Diamond Sheets .....	16
Mini Self-adhesive Diamond Sheets .....	16
Sanding Blocks.....	17
2 Way Sanding Blocks .....	17
Sanding Blocks for Ukuleles or Mandolins .....	17



### Fret work



Fret Cutters.....	18
Fret Pullers .....	19
Fret Tang Nippers .....	19
Fret Setter .....	20
Hammers .....	20
HOSCO Fretting Hammer .....	20
Twin Hammers .....	20
Fret Polishing / Sanding Rubbers .....	21
Zone File .....	22
Fret Leveling File.....	22
Diamond Fret Level and Crown Files .....	23
3 in 1 Diamond Fret Crown File.....	23
Compact Fret Crown Files.....	24
Fret Crown Files .....	24
UFO (Ultimate Fret crown Optimizer) .....	25
Fret-end Dressing Files .....	25



## Woodwork

### Saws, Knives, Chisels

	Japanese Kujiri (Eyeleteer) .....	26
	Fine Cut Saws .....	26
	Hand Jig Saw / Peghole Saw .....	26
	Flush Cutting Saw .....	27
	Azebiki Saw .....	27
	Dozuki Saws (Back Saws) .....	27
	Bracing Saw .....	27
	Knives .....	28
	High-end Fancy Kiridashi Knives .....	28
	Fancy Kiridashi Knives "UNRYU" .....	28
	Kiridashi Knives .....	29
	Wooden Handles for Japanese Kiridashi Knives .....	29
	Wood Curving Knife .....	29
	"Kuri" Knives with Special Wooden Handle .....	29
	"Kogatana" Knife set .....	30
	"Kuri" Knives .....	30
	Japanese Gouges .....	30
	Micro Chisels .....	31
	Japanese Chisels (Tataki-Nomi) .....	31

### Files, Sanding tools



	CP (Chemical Polishing) Files .....	32
	Flat CP Files .....	32
	Half-round CP Files .....	32
	Wood Saw Rasps .....	33
	Line Round Files .....	33
	Feather Edge and Feather Edge Diamond Files .....	34
	Feather Edge File .....	34
	Feather Edge Diamond Files .....	34
	Standard File Sets .....	34
	Sanding Sheets .....	35
	SHINEX Sanding Sheets .....	35
	Kovax Finish Repairing Papers and Rubber Blocks for KFRP .....	36
	Kovax Rubber Blocks for KFRP .....	36
	Kovax Rolled Sandpapers .....	37
	Self-adhesive Diamond Sheets .....	37
	Kovax Water Proof Sandpapers .....	37
	Mini Self-adhesive Diamond Sheets .....	37
	Sanding Blocks .....	38
	2 Way Sanding Blocks .....	38
	Sanding Blocks for Ukuleles or Mandolins .....	38
	Scrapers .....	39
	Wide Scrapers .....	39
	Standard Scraper Set .....	39
	Shaped Small Scraper Set .....	39

### Glue

	Hide Glue .....	40
	Binding Glue .....	41

## Working tools

### Gauges

	Step Gauges .....	42
	Fingerboard Radius Gauge .....	44
	Rulers w/ Inch Conversion Table .....	44
	Protractor .....	44
	Taper Gauge .....	45
	Mini Stainless Square .....	45
	Profiling Gauge .....	45
	Thickness Gauge .....	45



### Fine Tuning

	Guitar Nut Cube (5 in 1 wrench) .....	46
	Wrenches .....	47
	Hex Wrenches .....	47
	Truss Rod Wrenches .....	47

### Workshop Gadget

	2-way Neck Support .....	48
	Workbench Mat .....	48
	HOSCO Work Apron .....	49
	Tool Bags .....	49

## Tool Caring

	Ceramic Stones .....	50
	Ceramic Combination Stones .....	50
	Ceramic Single Stones .....	50
	Diamond Hones .....	51
	Table-top type Diamond Hones .....	51
	Handy-type Dual Grit Diamond Plates .....	51
	Tool Maintenance Oil .....	51

## Violin Tools

	Violin Nut Files .....	52
	Violin Nut Files .....	52
	Line Round Files .....	52
	Peghole Saw / Hand Jig Saw .....	52
	Kujiri (Eyeleteer) and Micro Chisels .....	52
	Japanese Gouges .....	53
	Knives .....	53
	Hide Glue .....	53
	Scrapers .....	53
	The Standard Scraper Set .....	53
	The Shaped Small Scraper Set .....	53

## Maintenance

	EASY FRET CARE .....	54
	Wiping Clothes .....	55
	HOSCO Ezo-deer skin cloth Made in Japan .....	55
	Professional Care Cloth for superior finish .....	55
	Humidity Control Items .....	56
	Fret Shield .....	56
	Hygrometer / Thermometer .....	57

## HOSCO Nut Work Table

H-NWT2



This Nut and Saddle shaping tool has 3 different tables with #600 grit diamond.

The H-NWT2 uses wear-resistant, self-lubricating POM resin for the body to reduce weight. Please be careful when using it outdoors or storing it, as it will turn yellow or deform when exposed to ultraviolet rays or light. Flat table and 90 degree angles are precisely processed by CNC machine. Size : 180 x 60 x 15mm Weight: 0.3 kg

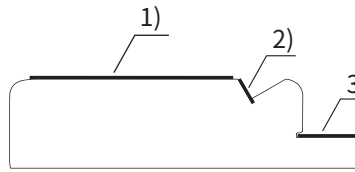

- 1) 35mm x 180mm flat table  
Use for flat surface job
- 2) 4mm x 180mm 90 degree corner table  
Use for 90 degree sanding of saddles
- 3) 10mm x 180mm 90 degree corner table  
Use for 90 degree sanding of nuts

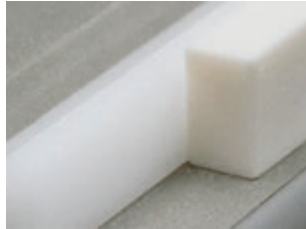

<b>NEW</b> H-NWT2	Nut Work Table2 / Diamond Sheet
H-NWT-600D	Diamond Sheet for H-NWT, for H-NWT2

\*The back of the diamond sanding sheet is an adhesive sheet.

## Nut and Saddle Shaping Files

3 different shapes (Flat, Half-round and Triangle) are available. All files are "non-clog" coated to ease removing sanding dusts of any material from the teeth.

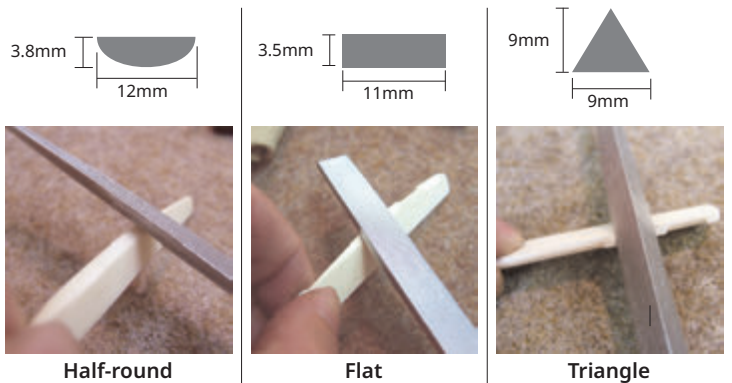
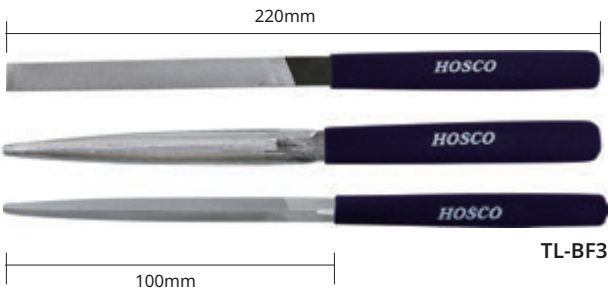

TL-BFHR	Half-round
TL-BFFL	Flat
TL-BFTRI	Triangle
TL-BF3	Set of 3 shapes / non-clog coated / Nut and Saddle Shaping File Set

# String Guide Saw



**H-SGSW**

Blade Thickness: 0.2mm (0.0078")  
Blade Pitch: 0.3mm (0.012")

It is surprisingly difficult to put a guide groove in an unmachined nut, and the nut file may slip. That is the case when this string guide saw helps. The blade thickness is 0.0078", which is thinner than that of a standard electric guitar's 1st string, so it can make a guide cut without affecting the nut groove. The black blade makes it easy to check the blade position, and the tip of the saw is not edged to prevent damage to the headstock or fingerboard. It can be used for either push or pull cutting.



**NEW H-SGSW** String Guide Saw

# GrooBar™ -Nut Slot Assist Tools-

The nut files can get to your target depth quickly.  
Material : Non-hardened steel / Size : 12.5mmx80mm



L Thickness : 1.07mm (0.042")



L Thickness : 1.27mm (0.050")



M Thickness : 1.42mm (0.056")

**H-GB4**

Nut Slot Assist Tool for guitars Set of 4

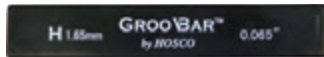

H Thickness : 1.65mm (0.065")



U Thickness : 0.81mm (0.032")



U Thickness : 0.91mm (0.036")



L Thickness : 1.07mm (0.042")

**H-GB4U**

Nut Slot Assist Tool for ukuleles Set of 4



L Thickness : 1.27mm (0.050")



Click here for explanation video.

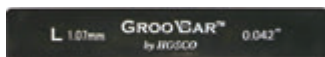

L Thickness : 1.07mm (0.042")

**H-GB-042**

0.042" Set of 4



L Thickness : 1.27mm (0.050")

**H-GB-050**

0.050" Set of 4

### Simplified chart for fret height and Groobar

Fret Height Range	Instruments	Groobar
0.6-0.7 mm	Ukuleles, Mandolins & Banjos	U-0.81
0.7-0.8 mm	Ukuleles, Mandolins & Banjos	U-0.91
0.8-1.0 mm	Guitars, Ukuleles, Mandolins & Banjos	L-1.07
1.0-1.2 mm	Guitars, Ukuleles, Mandolins & Banjos	L-1.27
1.2-1.3 mm	Guitars	M-1.42
1.3-1.4 mm	Guitars & Basses	H-1.65

### How to use



Choose one of Groobar.

File a nut to the Groobar.

Black-color is gone when done.

Move to the next slot.

<b>H-GB4</b>	for Guitar L2=0.042" (1.07mm) / L1=0.050" (1.27mm) / M=0.056" (1.42mm) / H=0.065" (1.65mm)
<b>H-GB4U</b>	for Ukulele U=0.032" (0.81mm) / U=0.036" (0.91mm) / L=0.042" (1.07mm) / L=0.050" (1.27mm)
<b>H-GB-042</b>	Set of 4 L2=0.042" (1.07mm)
<b>H-GB-050</b>	Set of 4 L1=0.050" (1.27mm)

Nut & Saddle work  
Head & Fingerboard work  
Fret work  
Saws, Knives, Chisels  
Files, Sanding tools  
Woodwork  
Glue  
Gauges  
Working tools  
Fine Tuning  
Workshop Gadget  
Tool Caring  
Violin Tools  
Maintenance

## Black Nut Files



Hosco Black Nut Files help you to do a nut filing job easily, quickly, and precisely.

Aluminum holder has 3 magnets to hold the nut file securely and curved-shaped holder gives you a comfortable grip.

All of the nut files are done with blackening treatment which is called black oxide finish.

Nut file size : 95 x 12mm

Mag-holder size : 105 x 20 x 10mm

Set a black nut file to the holder



H-NF-009



H-NF-012



H-NF-H

### Black Nut File Set

<a href="#">H-NF-EG009</a>	for Electric Guitars / Aluminum holder / Files 6pcs / .009/ .012/ .016/ .024/ .032/ .042
<a href="#">H-NF-EG010</a>	for Electric Guitars / Aluminum holder / Files 6pcs / .010/ .013/ .016/ .028/ .036/ .046
<a href="#">H-NF-AG</a>	for Acoustic Guitars / Aluminum holder / Files 6pcs/ .012/ .016/ .024/ .032/ .042/ .054
<a href="#">H-NF-CG</a>	for Classical Guitars / Aluminum holder / Files 6pcs / .028/ .032/ .036/ .042/ .040/ .046
<a href="#">H-NF-EB</a>	for Electric Basses / Aluminum holder / Files 5pcs / .046/ .065/ .085/ .105/ .130
<a href="#">H-NF-UK</a>	for Ukulele / Aluminum holder / Files 4pcs / .024/ .028/ .032/ .036

### Black Nut File

<a href="#">H-NF-H</a>	Aluminum holder
<a href="#">H-NF-009</a>	for Guitar / 0.009"
<a href="#">H-NF-010</a>	for Guitar / 0.010"
<a href="#">H-NF-012</a>	for Guitar / 0.012"
<a href="#">H-NF-013</a>	for Guitar / 0.013"
<a href="#">H-NF-016</a>	for Guitar / 0.016"
<a href="#">H-NF-024</a>	for Guitar / for Ukulele / 0.024"
<a href="#">H-NF-028</a>	for Guitar / for Ukulele / 0.028"
<a href="#">H-NF-032</a>	for Guitar / for Ukulele / 0.032"
<a href="#">H-NF-036</a>	for Guitar / for Ukulele / 0.036"
<a href="#">H-NF-040</a>	for Guitar / 0.040"
<a href="#">H-NF-042</a>	for Guitar / 0.042"
<a href="#">H-NF-046</a>	for Guitar / for Bass / 0.046"
<a href="#">H-NF-050</a>	for Guitar / for Bass / 0.050"
<a href="#">H-NF-054</a>	for Guitar / for Bass / 0.054"
<a href="#">H-NF-065</a>	for Guitar / for Bass / 0.065"
<a href="#">H-NF-075</a>	for Guitar / for Bass / 0.075"
<a href="#">H-NF-085</a>	for Bass / 0.085"
<a href="#">H-NF-090</a>	for Bass / 0.090"
<a href="#">H-NF-105</a>	for Bass / 0.105"
<a href="#">H-NF-130</a>	for Bass / 0.130"



# Diamond-combo Black Nut Files



Black nut file combined with #600 diamond line file by precise-welding technology. This side can be finished in a U-shape, allowing for a perfect fit between the string and the string groove.

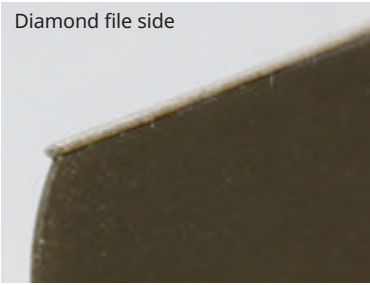
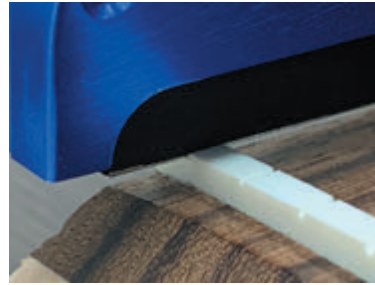

Diamond file side

This series offers four narrow gauges with difficult round-bottom finishes.



H-NF-010DC



H-NF-012DC



H-NF-013DC



H-NF-016DC



Click here for explanation video.

## How to use

Use Toothed file side first to make a nut slot near your target depth. Then use Diamond file side to make the nut slot half-round.

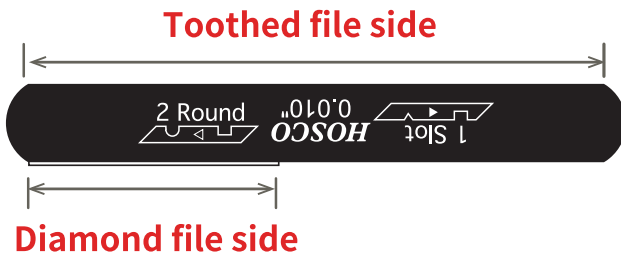

After first process with Toothed file

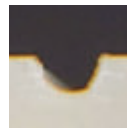

After final process with Diamond file

NEW	H-NF-010DC	for Guitar / 0.010"
NEW	H-NF-012DC	for Guitar / 0.012"
NEW	H-NF-013DC	for Guitar / 0.013"
NEW	H-NF-016DC	for Guitar / 0.016"

# Line Round Files



TL-BF5LR

TL-BF5LR is a high-quality line round file set which has special coating to avoid clogging. And this non-clog coating promises fine cutting and long life. This file set works for string slot job for violin nut or bridge, violin peg holes cleaning etc. We sell each size is sold separately.  
Total length : 100mm



TL-BF5LR	Set of 5 (0.8, 1.2, 1.5, 2.0, 2.5mm) , Non-Clog Coated Round
TL-BFLR08	0.8mm, Non-Clog Coated Round
TL-BFLR12	1.2mm, Non-Clog Coated Round
TL-BFLR15	1.5mm, Non-Clog Coated Round
TL-BFLR20	2.0mm, Non-Clog Coated Round
TL-BFLR25	2.5mm, Non-Clog Coated Round

Nut & Saddle work

Head & Fingerboard work

Fret work

Saws, Knives, Chisels

Files, Sanding tools

Glue

Gauges

Fine Tuning

Workshop Gadget

Tool Caring

Violin Tools

Maintenance

## Double Edge Nut Files



5 variations of Double-edge nut file sets are available.

For acoustic guitars, electric basses, classical guitars, electric guitars, and ukuleles.  
Total length : 190mm Blade length : 100mm

TL-NF3A



TL-NF3C



TL-NF3U



TL-NF3B



TL-NF3E



TL-NF3A	Set of 3 / for Acoustic Guitar / .016 / .042 , .026 / .050 , .036 / .055
TL-NF3B	Set of 3 / for Bass / .045 / .085 , .065 / .105 , .075 / .130
TL-NF3C	Set of 3 / for Classical Guitar / .030 / .038 , .032 / .042 , .035 / .046
TL-NF3E	Set of 3 / for Electric Guitar / .010 / .026 , .013 / .036 , .017 / .046
TL-NF3U	Set of 3 / for Ukulele / .022 / .028 / .024 / .032 / .026 / .036

※Please select the suitable file for use from the variation.

## Edge-Cut Nut Files



Various accurate gauges are available.

TL-NF10 has 10 variation and TL-NF11 has 11 variation.

Each file is available individually.

Total length : 150mm

Blade length : 115mm



TL-NF10



TL-NF11



### for Guitar

TL-NF10	Set of 10 / .010 / .013 / .016 / .024 / .028 / .032 / .036 / .042 / .046 / .056 w/ case
TL-NF11	Set of 11 / TL-NF10 + .050 w/ case
TL-NF-010	for Guitar / .010"
TL-NF-013	for Guitar / .013"
TL-NF-016	for Guitar / .016"
TL-NF-024	for Guitar / .024"
TL-NF-028	for Guitar / .028"
TL-NF-032	for Guitar / .032"
TL-NF-036	for Guitar / .036"
TL-NF-042	for Guitar / .042"
TL-NF-046	for Guitar / .046"
TL-NF-050	for Guitar / .050"
TL-NF-056	for Guitar / .056"

## for Violin

These nut files are designed for filing the slots for strings of violins. It brings accurate works. The set comes with a plastic cylinder case.

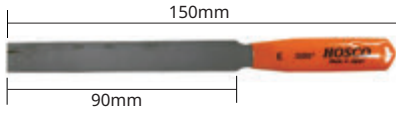

Teeth per inch : 76 cut (for E, A, and D strings)  
Teeth per inch : 78 cut (for G string)

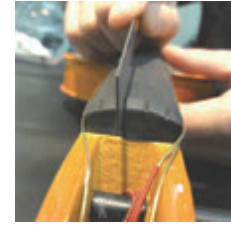
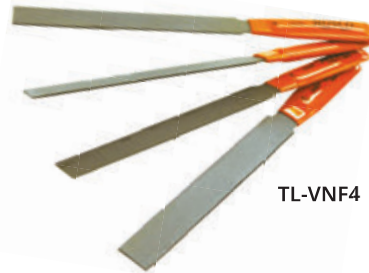

TL-VNF4	Edge-Cut Violin Nut Files Set of 4 ( E .020", A .026", D .032", G .040")
TL-VNF4/E	Edge-Cut Violin Nut File for E string

## Saddle Slot Files



Very unique saddle slot files.  
Easy to flatten the saddle slot and make it clean.  
The round-shape on both ends fits the ends of saddle slot.

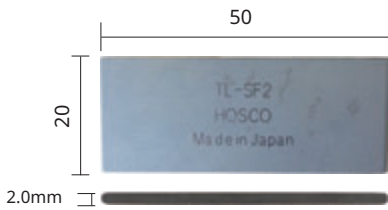

TL-SF2

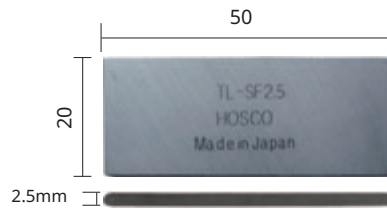

TL-SF2.5



TL-SF3

TL-SF2	Thickness : 2mm
TL-SF2.5	Thickness : 2.5mm
TL-SF3	Thickness : 3mm

Nut &  
Saddle work

Head &  
Fingerboard  
work

Fret work

Saws, Knives,  
Chisels

Files,  
Sanding tools  
Woodwork

Glue

Gauges

Fine Tuning  
Working tools

Workshop  
Gadget

Tool Caring

Violin Tools

Maintenance

## Step Drill Bits

All of our step drill bits are made of HSS(high speed steel) and promise fine job for making holes. Drill bit blade is specially designed to drill hard wood like maple.

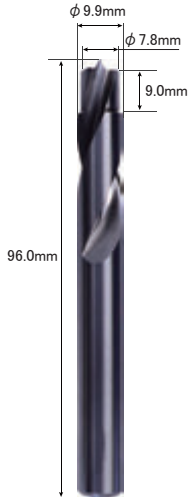

**TL-DB2-7899**

For installing Rotomatic type tuners  
Shank : 9.9mm diameter  
7.8mm and 9.9mm dia. holes can be drilled at a time



Cross section of drilled hole

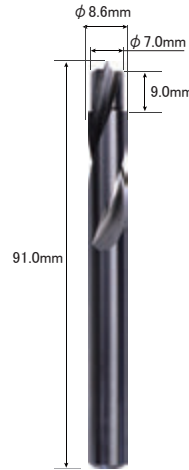

**TL-DB2-7086**

Shank : 8.6mm diameter  
7.0mm and 8.6mm dia.holes can be drilled at a time



Cross section of drilled hole

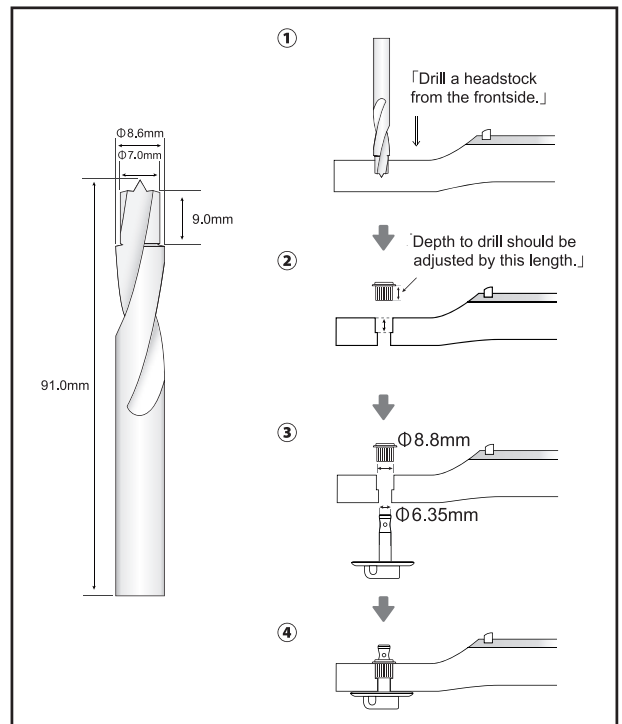
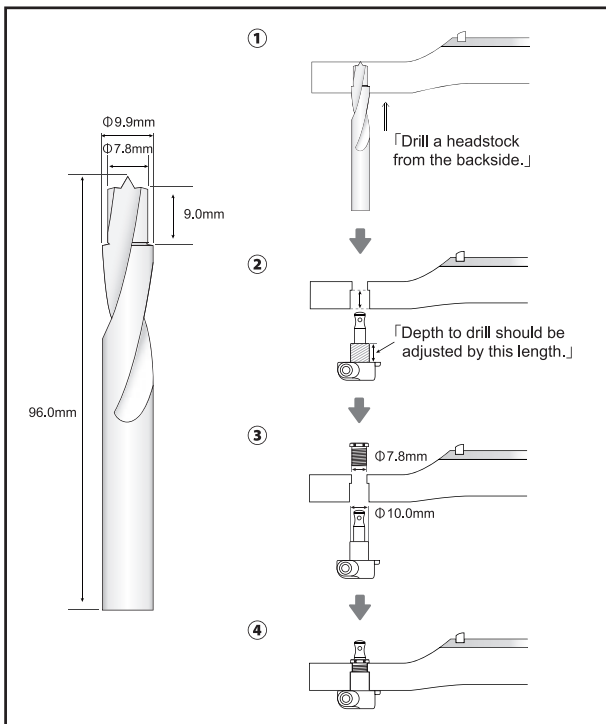

TL-DB2-7899	Step Drill Bits $\phi 7.8/9.9$
TL-DB2-7086	Step Drill Bits $\phi 7.0/8.6$



# Jewelers Saws

## Super Q Jewelers Saw Handle

The TL-JSW-490 can be used for cutting shells.  
The length can be adjusted and the depth is 75mm.  
Wooden handle. Made of hard wood.



TL-JSW490

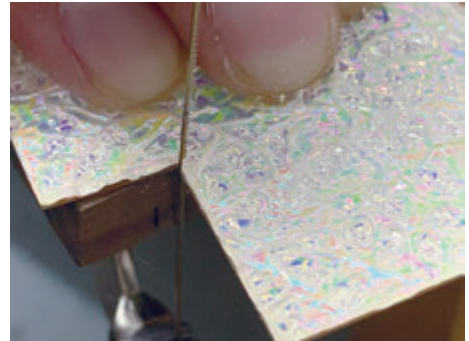

TL-JSW490	Jewelers Saw Handle
-----------	---------------------

## Jewelers Saw Super Q Blades

6 different size saw blades are available to cover various inlay cutting jobs. All blades are multi-purpose reliable blades. Sold per dozen.  
Please check each blade thickness and width below.



**SUPER Q Five-S**  
Super Quality  
Super Precision  
Super Elastic  
Super Sharp  
Super Performance of Alloy



B  
A

	A	B	Blade length	teeth / cm
TL-JSWB-6/0	0.36mm	0.18mm	130mm	32
TL-JSWB-4/0	0.44mm	0.22mm	130mm	26.5
TL-JSWB-2/0	0.52mm	0.26mm	130mm	22
TL-JSWB-0	0.56mm	0.28mm	130mm	20.5
TL-JSWB-1	0.60mm	0.30mm	130mm	19
TL-JSWB-2	0.70mm	0.34mm	130mm	17.5

TL-JSWB-6/0	Super Q Blades
TL-JSWB-4/0	Super Q Blades
TL-JSWB-2/0	Super Q Blades
TL-JSWB-0	Super Q Blades
TL-JSWB-1	Super Q Blades
TL-JSWB-2	Super Q Blades

Nut & Saddle work	Head & Fingerboard work	Fret work	Saws, Knives, Chisels	Files, Sanding tools	Glue	Gauges	Fine Tuning	Workshop Gadget	Tool Carving	Violin Tools	Maintenance
-------------------	-------------------------	-----------	-----------------------	----------------------	------	--------	-------------	-----------------	--------------	--------------	-------------

## Fret Slot Cutting Saws

TL-H-FSW050



TL-H-FSW053



TL-H-FSW057



TL-H-FSW060



enlarged photo of TL-H-FSW blade



Universal cutting teeth and the tooth spacing is 1.25mm.  
Material : Carbon Steel

TL-H-FSW050H



TL-H-FSW053H



TL-H-FSW057H



TL-H-FSW060H



enlarged photo of TL-H-FSWH blade



Cross cut teeth and the tooth spacing is 1.07mm.  
Material : YSS (Yasuki Specialty Steel)

TL-H-FSW050	Carbon steel / Thickness : 0.50mm / Blade length 120mm
TL-H-FSW053	Carbon steel / Thickness : 0.53mm / Blade length 120mm
TL-H-FSW057	Carbon steel / Thickness : 0.57mm / Blade length 120mm
TL-H-FSW060	Carbon steel / Thickness : 0.60mm / Blade length 120mm
TL-H-FSW050H	YSS (Yasuki Specialty Steel) / Thickness : 0.50mm / Blade length 120mm
TL-H-FSW053H	YSS (Yasuki Specialty Steel) / Thickness : 0.53mm / Blade length 120mm
TL-H-FSW057H	YSS (Yasuki Specialty Steel) / Thickness : 0.57mm / Blade length 120mm
TL-H-FSW060H	YSS (Yasuki Specialty Steel) / Thickness : 0.60mm / Blade length 120mm

## Fret Slot Cleaning Saws

TL-H-SCSW



SCSW series are "Pencil grip" cleaning saw and have 45 degrees for tip angle for easier cleaning up each slot end.

You can choose 2 different blade Thickness.



Special designed cutting blade.  
Short distance between blade and your hand makes easy control and delicate treatment. Pull stroke for cleaning.

TL-H-SCSW040	Blade thickness : 0.40mm / Tooth spacing : 0.9mm / Blade length : 15mm
TL-H-SCSW050	Blade thickness : 0.50mm / Tooth spacing : 0.9mm / Blade length : 15mm

TL-H-SCSWD



Our fret slot cleaning saws are designed for easier and faster cleaning. SCSWD series have 2 different special blades (Ryoba style). One is pull-cut and the other is push-cut. You can clean up each fret slot edge quickly and perfectly!



Pull side blade

Push side blade

Bidirectional saw

TL-H-SCSWD04	Blade thickness : 0.40mm / Tooth spacing : 0.9mm / Blade length : 15mm
TL-H-SCSWD05	Blade thickness : 0.50mm / Tooth spacing : 0.9mm / Blade length : 15mm

# Fret Slot Saw Guide



**H-FSWG**

This fret slot saw guide is designed for HOSCO fret slot saws (Page 14). Fret slot depth can be controlled from approx. 0.0mm - 4.7mm. Each side of the base has a detachable 0.3mm thickness silicone rubber sheet to grip a fingerboard.

(We recommend to use a clamp and in this case, remove upper silicon sheet.)

3 Neodymium magnets backed Polyacetal guide draws the saw blade and support the cutting straightly and at right angle to the fingerboard. Stainless steel made.



**H-FSWG-PG**

Polyacetal guide only  
(3 Neodymium magnets assembled)

<b>H-FSWG</b>	Size : 195 x 90 x 25mm, Weight : 475g.
<b>H-FSWG-PG</b>	Size : 14 x 70 x 4mm / Contain : Guide x 1 (w/ 3 Neodymium magnets), Screw x 2, Nut x 2

## How use use

### 1. Set the slot depth

Loosen the wing nuts and screws to slide the frame and tighten them again at proper position.

1 scale mark means approx.1.2mm depth adjustment.

2 faces give different height adjust. Plase refer the following photos.

Deep cut positions (approx. 4.7 - 2.5mm)



Shallow cutpositions (approx. 2.5 - 0.0mm)

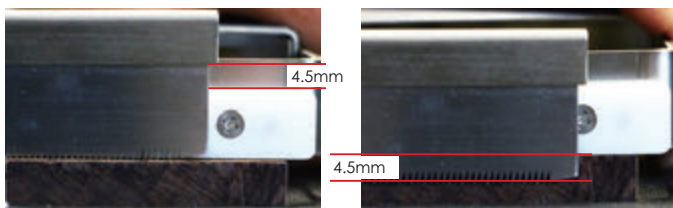
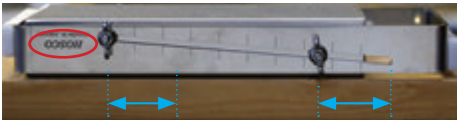

The distance between steel back bottom and guide top will be the cutting depth. Please adjust the slide frame to get the target depth.



The saw goes vertically against a fingerboard and it stops at your depth by touching the saw steel back and polyacetal guide.



The saw goes straight stably along the polyacetal guide. It is easy to check visually where you are cutting.

### 2. Set the guide on the fingerboard



Marking the center line on the fingerboard. It is a guide line for Fret Saw Guide. And then set the guide which both triangle cut center mark (This mark is on the polyacetal guide) is on this line.

### 3. Set Fret saw and cut the fret slot

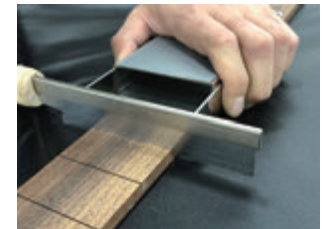
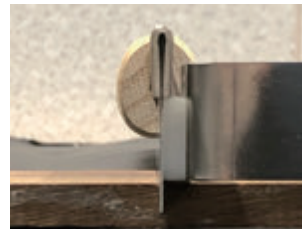

3 neodymium magnets catch the saw blade. Before cutting, please check the saw angle and cut gently.



The instruction movie from the QR code will show you how to use the H-FSWG.

Nut & Saddle work	Head & Fingerboard work	Fret work	Saws, Knives, Chisels	Files, Sanding tools	Glue	Gauges	Fine Tuning	Workshop Gadget	Tool Carving	Violin Tools	Maintenance
-------------------	-------------------------	-----------	-----------------------	----------------------	------	--------	-------------	-----------------	--------------	--------------	-------------



## Low Tack Masking Tapes

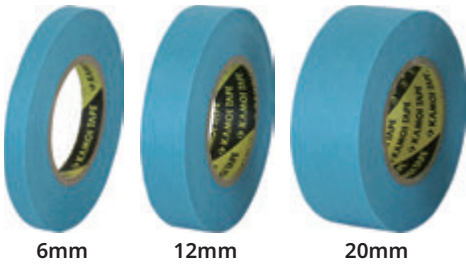

6mm

12mm

20mm

This masking tape is specially developed for wood work by one of the leading masking tape factories in Japan. The glue is not too strong to damage the fingerboard surface, but good enough for a fret job. 3 different width masking tapes are available and they are sold as a set and also individually.

Tape length : 18m (20yd)

Tensile strength : 68.1N/15mm

Tape thickness : 0.10mm

Inner diameter : 30mm

Adhesive force : 1.08N/10mm

Outer diameter : 55mm



The dispenser on the photo is not available.

H-MASKT-SET	Masking Tape set (6mm, 12mm and 20mm)
H-MASKT-6P	6mm width, Pack (20pcs)
H-MASKT-12P	12mm width, Pack (10pcs)
H-MASKT-20P	20mm width, Pack (6pcs)

H-MASKT-6B	6mm width, Box (200pcs)
H-MASKT-12B	12mm width, Box (100pcs)
H-MASKT-20B	20mm width, Box (60pcs)

## Sanding Materials

### Kovax Rolled Sandpapers

This rolled sandpapers are self-adhesive and are suitable to use with TWSB series sanding blocks.



KCR100

KCR120

KCR150

KCR240



KCR320

KCR400

KCR600

KCR100	#100 / 64mm x 1.4m
KCR120	#120 / 64mm x 1.8m
KCR150	#150 / 64mm x 2.2m
KCR240	#240 / 64mm x 2.6m
KCR320	#320 / 64mm x 3.2m
KCR400	#400 / 64mm x 3.4m
KCR600	#600 / 64mm x 3.4m



### Self-adhesive Diamond Sheets

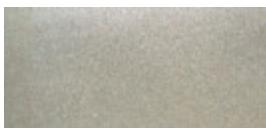

TDS100

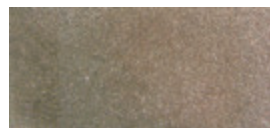

TDS400

Suitable to use with our TWSB series sanding blocks.

100-grit and 400-grit are available.

Easy to cut by knives or scissors.



TDS100	#100 / 75 x 150mm
TDS400	#400 / 75 x 150mm

### Mini Self-adhesive Diamond Sheets



IDS-150



IDS-300



IDS-600



IDS-1200

The Mini Self-adhesive Diamond Sheets are now available in 4 different grits.

The small size is good for ukulele or mandolin fret leveling work with sanding block. (TWSB-12U or TWSB-16U)

Or any purpose for sanding or sharpening tools.

It is very flexible and easy to cut to any sizes.

IDS-150	#150 / 50 x 100mm
IDS-300	#300 / 50 x 100mm
IDS-600	#600 / 50 x 100mm
IDS-1200	#1200 / 50 x 100mm



# Sanding Blocks

## 2 Way Sanding Blocks



The Hosco original Wooden Sanding Blocks. Each block has 2 different radiuses on each side as shown, helps you saving the space and cost. Save time of fret leveling or fingerboard job with our new Diamond sheets or Kovax self-adhesive sandpapers.



**TWSB-1**  
7-1/4" (184mm) / 9-1/2"(241mm)



**TWSB-2**  
10" (254mm) / 12"(305mm)



**TWSB-3**  
14" (356mm) / 16"(406mm)



**TWSB-4**  
15" (381mm) / 20"(508mm)

<a href="#">TWSB-1</a>	184R(7-1/4") / 241R(9-1/2") / Size : 80 x 150mm / Sanding area : 65 x 150mm
<a href="#">TWSB-2</a>	254R(10") / 305R(12") / Size : 80 x 150mm / Sanding area : 65 x 150mm
<a href="#">TWSB-3</a>	356R(14") / 406R(16") / Size : 80 x 150mm / Sanding area : 65 x 150mm
<a href="#">TWSB-4</a>	381R(15") / 508R(20") / Size : 80 x 150mm / Sanding area : 65 x 150mm

## Sanding Blocks for Ukuleles or Mandolins



Most of ukulele fingerboards are still flat, but nowadays radiused fingerboard is getting popular.

We developed two models with different radiuses.

One side is flat and the other side is radiused on both of the two models.

The flat side is also suitable to traditional mandolin fingerboards.

100mm(L) x 60mm(W) x 35mm(H) size fits ukulele and mandolin fingerboard work.



**TWSB-12U**  
12" (305mm) / Flat



**TWSB-16U**  
16" (406mm) / Flat



<a href="#">TWSB-12U</a>	305R (12") / Flat
<a href="#">TWSB-16U</a>	406R (16") / Flat

Nut & Saddle work

Head & Fingerboard work

Fret work

Saws, Knives, Chisels

Files, Sanding tools Woodwork

Glue

Gauges

Fine Tuning Working tools

Workshop Gadget

Tool Caring

Violin Tools

Maintenance

## Fret Cutters

### for Nickel silver Fretwire

TL-FC190

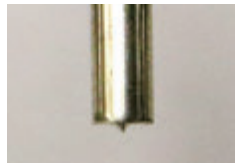

Cut end by normal cutting plier



cut end by TL-FC190

We developed this fret cutter at the factory who has a history of nearly 100 years in making cutting pliers per Japanese traditional methods.

The material is made of special steel called High Carbon tool steel.

190mm total length with 29mm blade width.

Flat and sharp cutting edge makes very flat fret end.

This is not suitable for stainless frets.



TL-FC190

Fret Cutter/ for Nickel silver Fretwire

### for Stainless steel Fretwire



Having a closer approach to the fretboard side, TL-FC28S leaves the cut end as little as 1 m/m. A Small remainder makes a big difference.

The leverage cutter of high carbon steel saves your time and labor after all.

TL-FC28S

#### Features

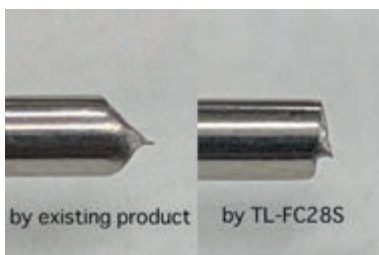

\*Blades on existing product bite off, while TL-FC28S cut right at the contact point.



This picture clearly shows how minutely the blade tip have been designed for both easy-cutting and endurance.

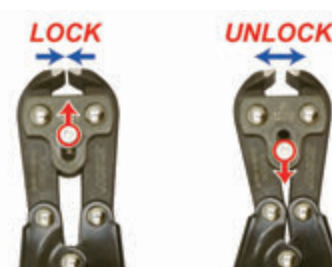

For your safety and prevention of unexpected damage to the neck, this TL-FC28S has a T-shaped lock system with an oblong cutout in the center. Slide it upwards to LOCK, or downwards to UNLOCK.



Specially designed blades  
leave the cut end minimal  
Rubber Grip  
for comfortable cut without slip

**NEW** TL-FC28S

Fret Cutter / for Stainless steel Fretwire

# Fret Pullers



TL-TC5 TL-TC10

TL-TC10 and TC5 have flattened blade.  
 TC10 is our best seller model and TC5 is new narrow blade model. This is good for tight radius fret work.  
 Not suitable to cut the wires but good for just pulling out the frets from fingerboard.  
 Material: Carbon Steel (S58C)  
 HRC: 42~47  
 Length: 150mm



TL-TC5 blade shape TL-TC10 blade shape



## Features

### More precision work

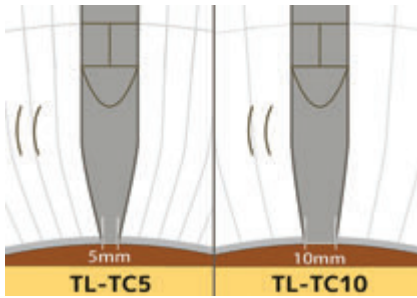

TL-TC5 with narrower blades can fit the radius of fingerboard more tightly.

### Better handling at narrow space

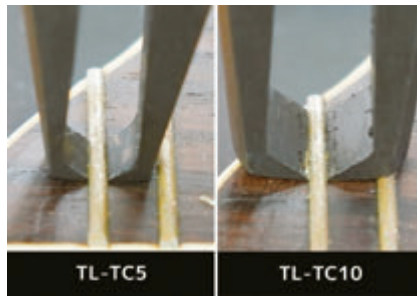

TL-TC5 can be handled more easily on higher fret position.

### Reducing wood chip out

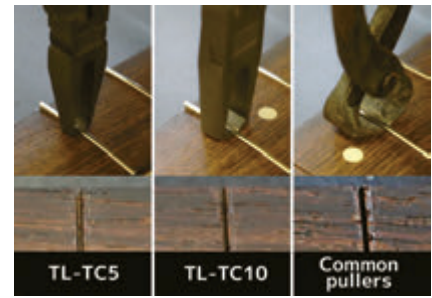

Both TL-TC5 and TL-TC10 may have less wood chip than common pullers.

<b>NEW</b>	<b>TL-TC5</b>	Fret Puller / Blade width:5mm
<b>NEW</b>	<b>TL-TC10</b>	Fret Puller / Blade width:10mm

# Fret Tang Nippers

We line up 2 versions for medium and for jumbo size fret.  
 170mm in length and 250g in weight.  
 It helps your fret tang cutting job easily.

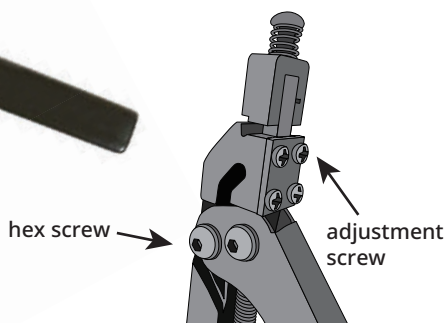

Before cutting After cutting

<b>H-FTN-J</b>	for Jumbo frets
<b>H-FTN-M</b>	for Medium frets

Nut & Saddle work	Head & Fingerboard work	Fret work	Saws, Knives, Chisels	Files, Sanding tools	Glue	Gauges	Fine Tuning	Workshop Gadget	Tool Caring	Violin Tools	Maintenance
-------------------	-------------------------	-----------	-----------------------	----------------------	------	--------	-------------	-----------------	-------------	--------------	-------------



## Fret Setter



TL-FS10

Material: Brass  
Length : 10cm  
Diameter : 7mm

The TL-FS10 is useful for resetting frets without loosing the strings.  
Brass made, 10cm long Fret Setter  
The 7mm diameter slim body helps a fretting job easily.  
Suitable for small, medium and jumbo fretwires

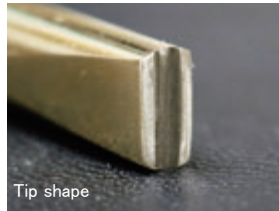

Tip shape



TL-FS10	Brass, Length : 10cm, Diameter : 7mm
---------	--------------------------------------

## Hammers

### HOSCO Fretting Hammer



TL-HMF-S

For fretting  
Head Material : Bronze  
Head : Octagonal Shape, 60 x 15 x 17 mm  
Total length : 300mm



Octagonal head ideal for fretting  
The sides can also be used for hammering on a wide surface.

TL-HMF-S	Octagonal Shape Hammer
----------	------------------------

### Twin Hammers

TL-HMT have 2 different heads.  
One is steel head and another is plastic head.  
Use plastic head for fretting works.



TL-HMT-L

Weight : 225g

For fretting  
Head : 25mm dia. x 75mm  
Total length : 330mm



TL-HMT-S

Weight : 115g

For fretting  
Head : 17mm dia. x 64mm  
Total length : 300mm



TL-HMT-L	Japanese Hammer (Twin Heads), Large
TL-HMT-S	Japanese Hammer (Twin Heads), Small



# Fret Polishing / Sanding Rubbers

With Fret Polishing Rubber / Fret Sanding Rubber, you don't even need a masking tape ready to clean frets without dirtying your hands or the fingerboard.

## Fret Polishing Rubbers



Easy and fast fret polishing tool.  
Erasing the small scratches of the fret or Polishing the dirty frets. Because of this softness, rubber fits to fret arch perfectly. Also soft rubber keeps the fingerboard damage to a minimum. Easy to cut this rubber by cutter knife for your fret work. This is a great rust remover and polisher!

<a href="#">FPR180</a>	Size : 65 x 18 x 9mm / #180 / 2pcs
<a href="#">FPR400</a>	Size : 65 x 18 x 9mm / #400 / 2pcs
<a href="#">FPR1000</a>	Size : 65 x 18 x 9mm / #1000 / 2pcs

## Fret Sanding Rubber



Easy and fast fret end sanding tool.  
After the fret beveling job by files, you can save time to make fret bevels smooth by this fret sanding rubbers.

<a href="#">FSR150</a>	Size : 65 x 18 x 9mm / #150 / 2pcs
------------------------	------------------------------------

## Fret Polishing & Sanding Rubber Set

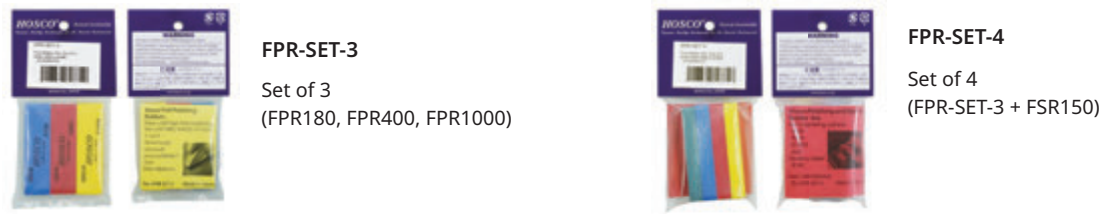

<a href="#">FPR-SET-3</a>	Set of 3 ( #180 / #400 / #1000 ) / 1pc each
<a href="#">FPR-SET-4</a>	Set of 4 ( #150 / #180 / #400 / #1000 / ) / 1pc each

- Nut & Saddle work
- Head & Fingerboard work
- Fret work
- Saws, Knives, Chisels
- Files, Sanding tools
- Glue
- Gauges
- Fine Tuning
- Workshop Gadget
- Tool Carrying
- Violin Tools
- Maintenance

## Zone File

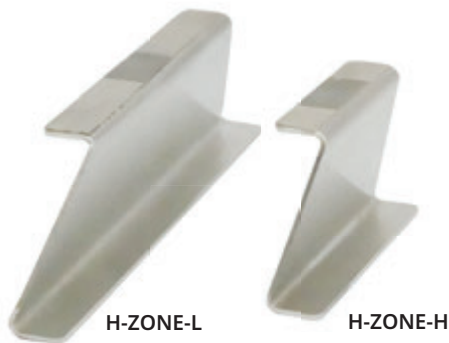

The Zone File is a unique tool that allows you to check the fret level while the strings are on, if necessary, make adjustments with a diamond file as it is. The name "Zone File" is derived from its unique "Z" shape and its meaning of checking and adjusting a specific "zone" of three adjacent frets.

To cover the zone from the low fret to the high fret, four lengths were needed. For this reason, the Zone files were designed in a trapezoidal shape, and two files make one set. (Pat. Pend.) This "Z" shape has a meaning. The edge of the "Z" is used as a straight edge gauge to check fret rattling, and the diamond file in the center of the "Z" flat surface is to adjust the rattling.



- \* Size: (ZONE-L) 105 /75 (l) x 30 (h) x 10 (w) mm / (ZONE-H) 50 /35 (l) x 30 (h) x 10 (w) mm
- \* Diamond file : #800 grit, (ZONE-L) 15x8mm + 15x8mm / (ZONE-H) 12x8mm + 10x8mm
- \* Material : Stainless steel, 1mm thick

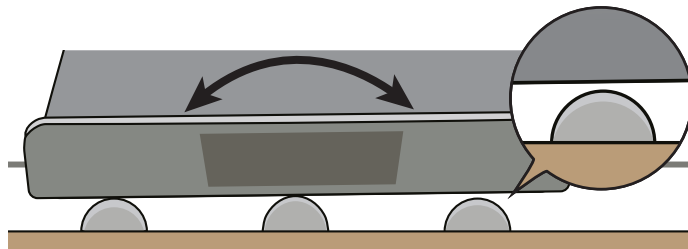

### You can check the fret level while strings are on!

- 1) Set the Zone file so that it passes under the strings to be checked.  
Select a zone file that is long enough to span the three frets to be checked.  
Tilt the zone file so that its edges touch the three frets, and check with both hands to see if there is any rattling.  
If there is no rattling, move the file by one fret and continue the check in the same manner.

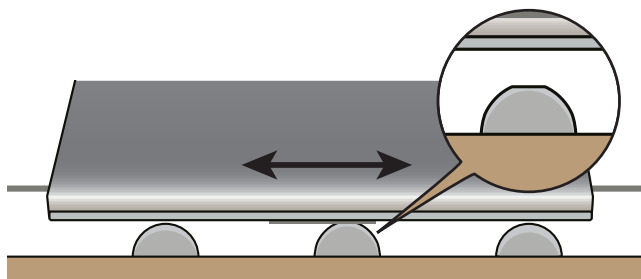

### You can adjust the fret level while strings are on!

- 2) If there is any sagging, it means that the center fret is high. So set the Zone file so that the diamond file surface touches the fret, and gradually polish to adjust it. While doing this, check as in step 1) to see if the fret level is even.  
If necessary, remove the strings and shape the crown with a crown file.

<b>NEW</b>	<b>H-ZONE</b>	Zone File set, set of 2
<b>NEW</b>	<b>H-ZONE-L</b>	Zone File for Low fret area
<b>NEW</b>	<b>H-ZONE-H</b>	Zone File for High fret area
<b>NEW</b>	<b>H-ZONE-LD</b>	Zone File Diamond Replacement Sheet for ZONE-L
<b>NEW</b>	<b>H-ZONE-HD</b>	Zone File Diamond Replacement Sheet for ZONE-H

## Fret Leveling File

### for Regular Fretwire

TL-FL160S



160mm(L) x 28mm(w) x 5mm(T) with single cut.  
Easy and fast work for fret leveling.



<b>TL-FL160S</b>	Fret Leveling File / 160 x 28 x 5mm
------------------	-------------------------------------

### for Stainless steel Fretwire

Special HC (hard chrome) coating is applied and developed for stainless steel frets.

TL-FL160SHC



for Stainless steel fretwire

<b>NEW</b>	<b>TL-FL160SHC</b>	Hard chrome coated Fret Leveling File / 160 x 28 x 5mm
------------	--------------------	--

# Diamond Fret Level and Crown Files



TL-FFLD12

TL-FFLD23

This unique 3 in 1 diamond file is HOSCO original design. Diamond fret leveling file with 2 types of crown files. 600-grit diamond can help your fret job faster with minimum scratches.

Size : 25mm x 160mm x 5mm.

Weight : 150g



600-grit Diamond

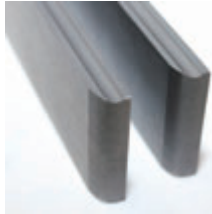

TL-FFLD12	Fret Crown File (R=1/R=2)/ Diamond fret leveling file #600 / 160 × 25 × 5mm
TL-FFLD23	Fret Crown File (R=2/R=3)/ Diamond fret leveling file #600 / 160 × 25 × 5mm

## 3 in 1 Diamond Fret Crown File



TL-FFD600



Small (R=1mm)

Medium (R=2mm)

Jumbo (R=3mm)

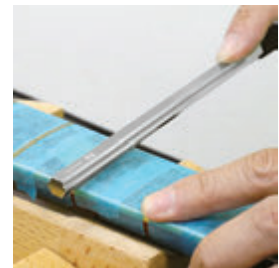

This fret crown file has three different radiuses in one file. It can be used according to type of fret crown, saying small standard (R=1mm), medium standard (R=2mm) and Jumbo (R=3mm)

### Difference in Electroplating process

HOSCO Original 3-in-1 Diamond Fret Crown File provides you with improved performance in adhesion, grind efficiency and abrasion resistance by fixing high quality, uniformed diamond particle in nickel electrodeposition.

#### Conventional products

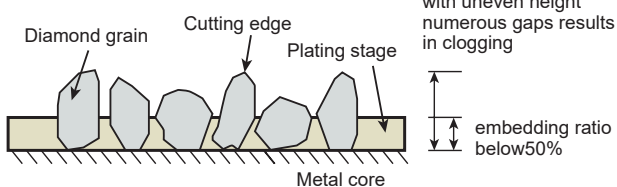

#### TL-FFD600

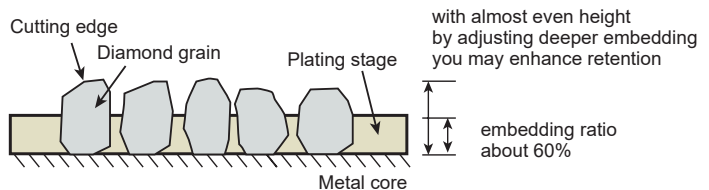

#### Before and after

High grade Diamond Grain and Nickel Electroplating process enabled High Grade sharpness, Hard to Clog and High durability.

TL-FFD600	3 in 1 Diamond Fret Crown File / #600/ (R=1 / R=2 / R=3)
-----------	--

- Nut & Saddle work
- Head & Fingerboard work
- Fret work
- Saws, Knives, Chisels
- Files, Sanding tools
- Glue
- Gauges
- Fine Tuning
- Workshop Gadget
- Tool Caring
- Violin Tools
- Maintenance

## Compact Fret Crown Files



These fret files are compact, enough to work even on the higher fret position, which closely contact to body top. The silicone rubber band securely holds the file.

Fine and coarse file teeth on both ends make the fret crown work more efficiently.

The rubber band showing coarseness and filing direction has been designed for usability.

File Size : 100 x 20 x 4mm without silicone rubber grip



Embossed mark on the silicone rubber is not only for holding. It shows the cutting edges (coarse or fine) cutting edge, fine (small triangle) or coarse (large triangle).



This arrow shows a filing direction. Please keep the direction in filing.

### for Regular Fretwire



H-FF1	Small: for ukuleles and mandolins / R=1mm
H-FF2	Medium: for standard frets / R=2mm
H-FF3	Large: for jumbo frets / R=3mm

### for Stainless steel Fretwire

HOSCO compact fret crown file for stainless steel frets is now available. Hard chrome coating is applied to the preceding model to accommodate hard stainless steel frets, and the file itself is also more durable.



<b>NEW</b>	H-FF2HC	Medium: for standard frets / R=2mm
<b>NEW</b>	H-FF3HC	Large: for jumbo frets / R=3mm

## Fret Crown Files



3 different radiuses are available. Small is for ukuleles and mandolins, medium is for standard frets, large is for wide frets.

Blade length : 105mm.  
Total length : 195mm.



TL-FF1	Small: for ukuleles and mandolins / R=1mm
TL-FF2	Medium: for standard frets / R=2mm
TL-FF3	Large: for jumbo frets / R=3mm



# UFO (Ultimate Fret crown Optimizer)



Conventional "stick" type crown file seemingly contacts frets lengthwise, but, due to the fact most fingerboards are with curve, it touches the fret at one point, without even knowing where you are sanding at. This UFO, a palm size disk, with the point of effort and load aligned, can transmit power straight right at the spot, at least you know where you want to sand visually.

Disk design : Palm size, easy to hold, control and see the filing point.  
 Concave file with 600 grit diamond : For fast and easy crowning.  
 Radius variation : 1.1mm - 1.8mm (UFO1 : 1.1-1.4mm, UFO2: 1.5-1.8mm)  
 Size : 50mm diameter x 7mm thick  
 Material : Steel in Nickel-plated  
 Weight : 95g

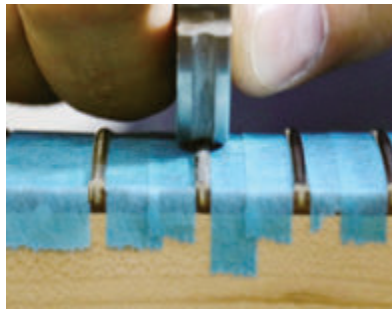
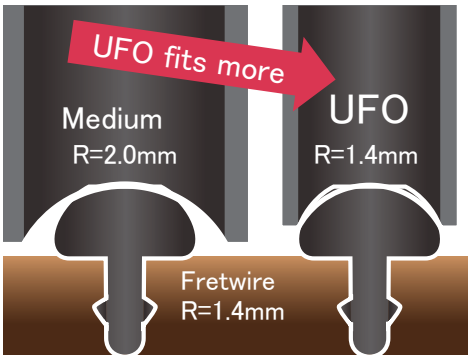
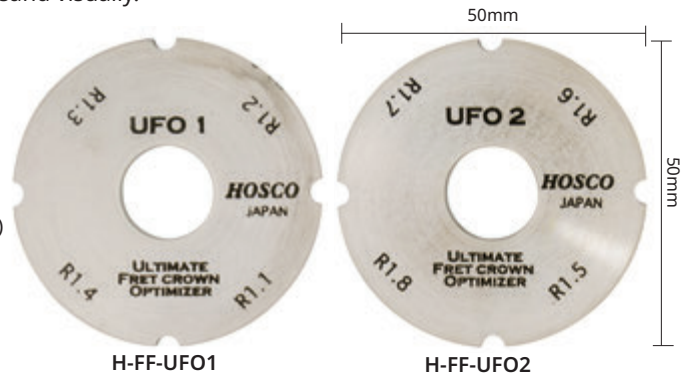

Click here for explanation video.

<b>NEW</b>	<b>H-FF-UFO1</b>	Ultimate Fret Crown Optimizer 1 / Radius : R1.1, R1.2, R1.3, R1.4
<b>NEW</b>	<b>H-FF-UFO2</b>	Ultimate Fret Crown Optimizer 2 / Radius : R1.5, R1.6, R1.7, R1.8

# Fret-end Dressing Files



Blade length : 35mm / Total length : 160mm.

This fret dressing file is designed for fret end work. This pencil-like shape gives you more precise file job. angled bottom is easy to fit on fingerboard with pencil-holding. There are 3 different radius sizes for regular fret and 2 different radius size for Stainless fret.

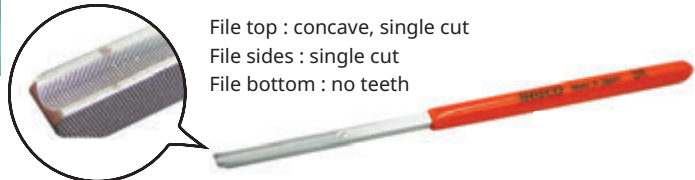

File top : concave, single cut  
 File sides : single cut  
 File bottom : no teeth

## for Regular Fretwire



<b>TL-FE1</b>	Small: for ukuleles and mandolins / R=1mm
<b>TL-FE2</b>	Medium: for standard frets / R=2mm
<b>TL-FE3</b>	Large: for jumbo frets / R=3mm

## for Stainless steel Fretwire

New fret end dressing files are released for stainless fret. 2 different radius sizes for medium and jumbo frets are available. These are hard chrome coated plating which works for hard stainless frets.



<b>NEW</b>	<b>TL-FE2HC</b>	Medium: for standard frets / R=2mm
<b>NEW</b>	<b>TL-FE3HC</b>	Large: for jumbo frets / R=3mm

- Nut & Saddle work
- Head & Fingerboard work
- Fret work**
- Saws, Knives, Chisels
- Files, Sanding tools
- Glue
- Gauges
- Fine Tuning
- Workshop Gadget
- Tool Caring
- Violin Tools
- Maintenance

## Japanese Kujiri (Eyeleteer)

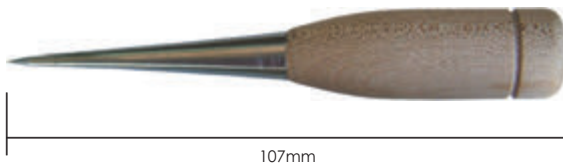

TL-KUJIRI-S

Material : Stainless

Very tough eyeleteer made by stainless steel with wooden grip.  
It works very well to make pilot holes for guitar tuner screws or pickguard screws etc.  
This tool is popular for violin making.  
It is useful for dot-marking and line-marking.

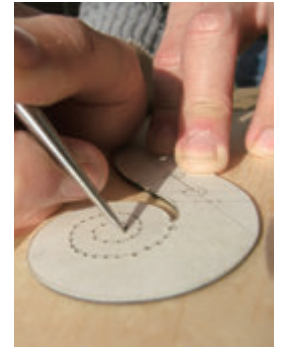

TL-KUJIRI-S

Material : Stainless

## Fine Cut Saws

The HOSCO Fine Cut Saws are featuring very thin blades, the thickness available in 0.1mm, 0.2mm and 0.3mm. You can use these saws to cut small piece of wood. etc. which requires very accurate jobs.

TL-H-FCSW103



TL-H-FCSW2



TL-H-FCSW103:  
The 0.3mm pitch blade can firmly capture and cut even the thinnest materials.

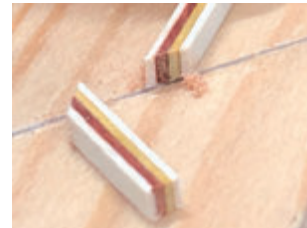

TL-H-FCSW3

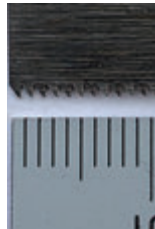
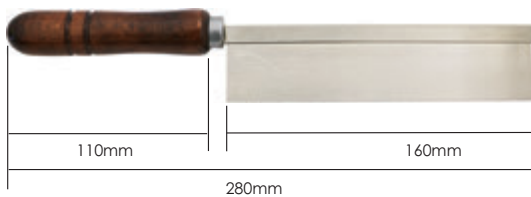

TL-H-FCSW103	0.1mm thick blade, 0.3mm pitch
TL-H-FCSW2	0.2mm thick blade, 0.9mm pitch
TL-H-FCSW3	0.3mm thick blade, 0.9mm pitch

## Hand Jig Saw / Peghole Saw

TL-H-VP



This saw was originally designed for cutting violin pegs.  
It is useful to cut in narrow place and it is stable with 0.4mm thick blade.



This saw can be used to cut the side of the guitar for installing EQ (Equalizer).

TL-H-VP	Blade thickness : 0.4mm / Blade pitch : 0.9mm
---------	---

# Flush Cutting Saw

The flush cutting saw has a high quality blade with short rib construction. The short rib construction prevents the blade tip from coming up in cutting.

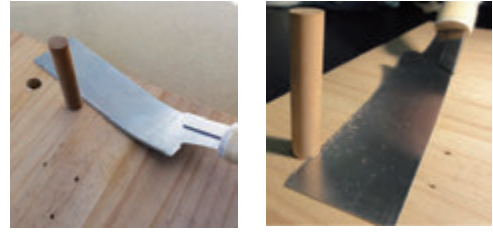
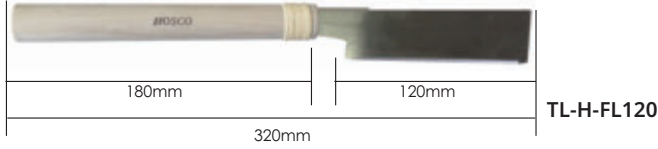

TL-H-FL120	Blade thickness is 0.4mm
------------	--------------------------

# Azebiki Saw

Azebiki saw has convex curved 60mm length blade. This works to cut from anywhere of the wood surface. 320mm total length and 180mm handle length. Blade thickness is 0.35 - 0.55mm tapered.

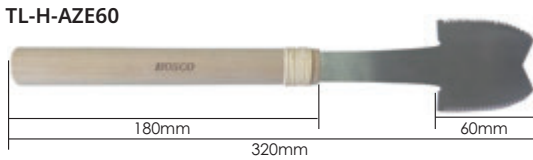

TL-H-AZE60	Azebiki Saw
------------	-------------

# Dozuki Saws (Back Saws)

The blade thickness is 0.3mm, reinforced with the rib for stable cutting.

TL-H-DS240 Total length : 600mm / Blade length : 240mm / Handle length : 300mm

TL-H-DS150 Total length : 350mm / Blade length : 150mm / Handle length : 180mm

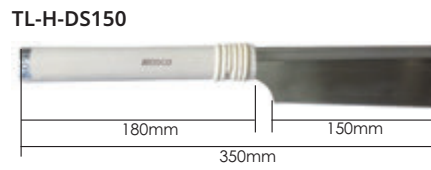
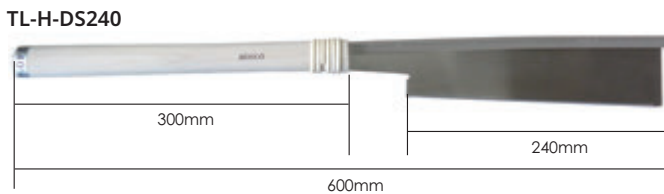

TL-H-DS240	Dozuki Saws (Back Saws), Blade length: 240mm
TL-H-DS150	Dozuki Saws (Back Saws), Blade length: 150mm

# Bracing Saw

This saw is designed mainly for cutting bracing.

Its round shaped blade allows you to put it into anywhere you want and to start cuts anywhere you want, it brings precise works. The wooden handle offers stable cutting.



TL-H-RSAW	Blade thickness: 0.2mm / Blade length: 66mm
-----------	---

Nut & Saddle work	Head & Fingerboard work	Fret work	Saws, Knives, Chisels	Files, Sanding tools	Glue	Gauges	Fine Tuning	Workshop Gadget	Tool Carving	Violin Tools	Maintenance
-------------------	-------------------------	-----------	-----------------------	----------------------	------	--------	-------------	-----------------	--------------	--------------	-------------

## Knives

## High-end Fancy Kiridashi Knives

These 2 type of fancy knives are made by hand with traditional method.

"Mokume" means "tree bark".

This finish can be made by old steel which is hard to get in nowadays.

"Unryu" means "movement of cloud". It is made of multi-layered steel.

The amazingly beauty of cloud pattern on the surface is only from the meister of blacksmith.

Engraved name with gold on the knife

Both knives are with Japanese traditional wooden case.

TL-I-KM21



"Mokume" knife, Right

TL-I-KU21



"Unryu" knife, Right



Mokume up



w/ the wooden case

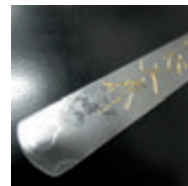

Unryu up



w/ the wooden case

TL-I-KM21	High-end Fancy Kiridashi Knives / Total length : 210mm
TL-I-KU21	High-end Fancy Kiridashi Knives / Total length : 210mm

## Fancy Kiridashi Knives "UNRYU"

The Meister and collector's choice. The top of line of violin maker's knives. Made of multi layered steel by hand forging. The amazingly beauty of cloud pattern on the surface is only from the meister of blacksmith.



Multi layered steel



Beautiful cloud pattern on the surface

## Bevel: Right

TL-I-UNRYU3R	width : 3mm
TL-I-UNRYU6R	width : 6mm
TL-I-UNRYU8R	width : 8mm
TL-I-UNRYU10R	width : 10mm
TL-I-UNRYU12R	width : 12mm
TL-I-UNRYU15R	width : 15mm
TL-I-UNRYU18R	width : 18mm

## Bevel: Left

TL-I-UNRYU3L	width : 3mm
TL-I-UNRYU6L	width : 6mm
TL-I-UNRYU8L	width : 8mm
TL-I-UNRYU10L	width : 10mm
TL-I-UNRYU12L	width : 12mm
TL-I-UNRYU15L	width : 15mm
TL-I-UNRYU18L	width : 18mm

## Bevel: Double (Right &amp; Left)

TL-I-UNRYU3D	width : 3mm
TL-I-UNRYU6D	width : 6mm
TL-I-UNRYU8D	width : 8mm
TL-I-UNRYU10D	width : 10mm
TL-I-UNRYU12D	width : 12mm
TL-I-UNRYU15D	width : 15mm
TL-I-UNRYU18D	width : 18mm



## Kiridashi Knives



These knives are made of two layered hand forged hardened steel. The most standard and reasonable knives.



Logo stamp is available for 10mm on up.



Left bevel knife is not only for left handed. This is useful for pull-cut for right handed.

### Bevel: Right

TL-I-K3R	width : 3mm
TL-I-K6R	width : 6mm
TL-I-K8R	width : 8mm
TL-I-K10R	width : 10mm
TL-I-K12R	width : 12mm
TL-I-K15R	width : 15mm
TL-I-K18R	width : 18mm

### Bevel: Left

TL-I-K3L	width : 3mm
TL-I-K6L	width : 6mm
TL-I-K8L	width : 8mm
TL-I-K10L	width : 10mm
TL-I-K12L	width : 12mm
TL-I-K15L	width : 15mm
TL-I-K18L	width : 18mm

### Bevel: Double (Right & Left)

TL-I-K3D	width : 3mm
TL-I-K6D	width : 6mm
TL-I-K8D	width : 8mm
TL-I-K10D	width : 10mm
TL-I-K12D	width : 12mm
TL-I-K15D	width : 15mm
TL-I-K18D	width : 18mm

## Wooden Handles for Japanese Kiridashi Knives



All Kiridashi Knives are without handles, but the handles are available as pictured.  
\*Each knife and handle is available for 3, 6, 8, 10, 12 & 15mm blade width.  
Wood material is Acacia.

NEW	TL-I-H3A	Blade width : 3mm / Handle length : 180mm
NEW	TL-I-H6A	Blade width : 6mm / Handle length : 180mm
NEW	TL-I-H8A	Blade width : 8mm / Handle length : 180mm
NEW	TL-I-H10A	Blade width : 10mm / Handle length : 180mm
NEW	TL-I-H12A	Blade width : 12mm / Handle length : 180mm
NEW	TL-I-H15A	Blade width : 15mm / Handle length : 180mm

## Wood Curving Knife



TL-I-CAKD

Japanese traditional designed and double beveled carving knife with wooden handle.



double beveled

TL-I-CAKD	Wood Curving Knife / Blade length : 60mm / Handle length : 140mm
-----------	--

## "Kuri" Knives with Special Wooden Handle

TL-I-KUKR

TL-I-KUKD



Right Bevel

TL-I-KUKL



Left Bevel



Double Bevel

It is same as Kiridashi knife but its pointed head allows you to process the places where you are unable to process by Kiridashi knives, such as a hole, a corner, a ditch and inside of a circle.

The original shaped handle brings nicer grip feeling.

13.5mm width blade, with wooden handle type

Wooden handle length : 139mm.

TL-I-KUKR	Right
TL-I-KUKL	Left
TL-I-KUKD	Double

Nut & Saddle work

Head & Fingerboard work

Fret work

Saws, Knives, Chisels

Files, Sanding tools

Glue

Gauges

Fine Tuning

Workshop Gadget

Tool Carving

Violin Tools

Maintenance

# Saws, Knives, Chisels

## "Kogatana" knife set



TL-I-6S



- ① All knives put into the Roll-up Bag.
- ② Fold back the upper side and roll it up.
- ③ All knives have an individual cover.

The essential carving knives in 6 different blades with nicer wooden handles in shape.

the knives included : Right, left & double beveled, Pointed right & left beveled and Chisel style

\*The knife set comes with "Roll-Up" style bag, to keep the knives in good condition. Individual knife covers are also included.

### Cutting Edge

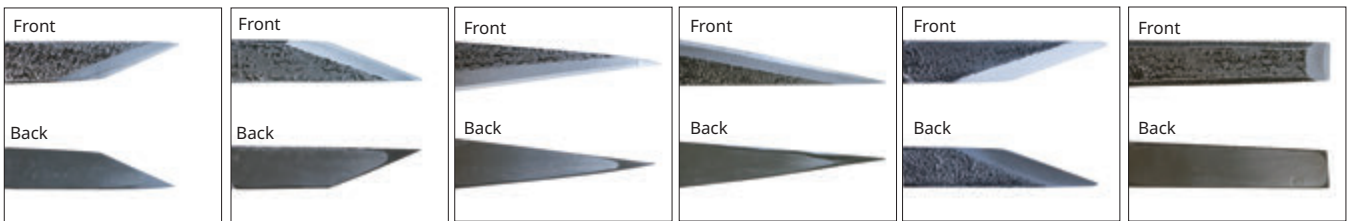

TL-I-6S

Total length : 157mm / Handle length : 95mm

## "Kuri" Knives

TL-I-KU10R



Total length : 160mm.  
Blade width : 10mm, no handle type

TL-I-KU10L

"Kuri" knife, Right



TL-I-KU10D

"Kuri" knife, Left



"Kuri" knife, Double



Kuri knife is useful to cut or shave small area like violin bridge shaping.

TL-I-KU10R

Right

TL-I-KU10L

Left

TL-I-KU10D

Double

## Japanese Gouges

Blade material is "Shiragami" white steel and HRC64. Total length : 180mm

TL-IGS9



Spoon Shape 9mm wide Blade

TL-IGS15



Spoon Shape 15mm wide Blade



Side view



TL-IGS15 blade

TL-IGS9

9mm wide Blade

TL-IGS15

15mm wide Blade

## Micro Chisels



High quality micro chisels with 2 different blade width, 1.1mm and 2.2mm. The long neck design is useful not only for nut slot or saddle slot works, but also suitable for cleaning the deep pocket area.

Blade is HSS (High Speed Steel) material .



TL-MC11

1.1mm width is good for violin purfling slot making.



TL-MC22

2.2mm width is good for guitar saddle slot work.

TL-MC11	Micro Chisel, Width : 1.1mm
TL-MC22	Micro Chisel, Width : 2.2mm

## Japanese Chisels (Tataki-Nomi)

The TL-INM chisels have a good balance of quality and costs. There are 8 different widths of the blade edge (from 3mm to 24mm). Hardness of blade : HRC63 Total length : 225mm

TL-INM3 3mm wide blade



TL-INM6 6mm wide blade



TL-INM9 9mm wide blade



TL-INM12 12mm wide blade



TL-INM15 15mm wide blade

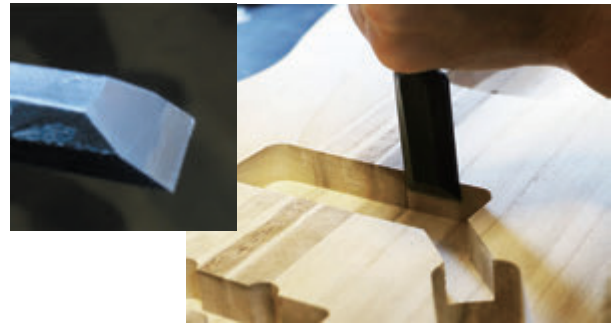

TL-INM18 18mm wide blade



TL-INM21 21mm wide blade



TL-INM24 24mm wide blade



TL-INM-SET4



TL-INM3  
(Blade width: 3mm / e.g.: for cleaning nut slot on ST/TL type guitars)



TL-INM6  
(Blade width: 6mm / e.g.: for making a channel for truss rod)



TL-INM12  
(Blade width: 12mm / e.g.: for using on pickup cavities, a neck joint, and bracings)



TL-INM24  
(Blade width: 24mm / e.g.: ditto)



H-TB1V  
(Roll-up bag)

TL-INM3	Japanese Chisels (Tataki-Nomi) / 3mm wide Blade
TL-INM6	Japanese Chisels (Tataki-Nomi) / 6mm wide Blade
TL-INM9	Japanese Chisels (Tataki-Nomi) / 9mm wide Blade
TL-INM12	Japanese Chisels (Tataki-Nomi) / 12mm wide Blade
TL-INM15	Japanese Chisels (Tataki-Nomi) / 15mm wide Blade
TL-INM18	Japanese Chisels (Tataki-Nomi) / 18mm wide Blade
TL-INM21	Japanese Chisels (Tataki-Nomi) / 21mm wide Blade
TL-INM24	Japanese Chisels (Tataki-Nomi) / 24mm wide Blade

**NEW** TL-INM-SET4 | Japanese Chisel set of 4 (3, 6, 12, 24 mm) with Roll-up bag

Saddle work	Nut &
	Fingerboard work
Fret work	Head &
	Saws, Knives, Chisels
Woodwork	Files, Sanding tools
	Glue
Working tools	Gauges
	Fine Tuning
	Workshop Gadget
Tool Carrying	
Violin Tools	
Maintenance	

## CP(Chemical Polishing) Files

The CP files have special file tooth pattern and it keeps file clean without clogging.

It works incredibly fine for wood filing! Give it a try to believe it.

No pressure required.

The CP files are easy to control and fast to file clean with light strokes.

Teeth per inch : 22 cut



Enlarged CP files tooth.  
This tooth shape is the secret of why CP file works fine!

Normal File

CP File



Comparison between CP file and normal wood file

Left : 10 strokes by normal wood file

Right : 1 stroke by CP file

### Flat CP Files

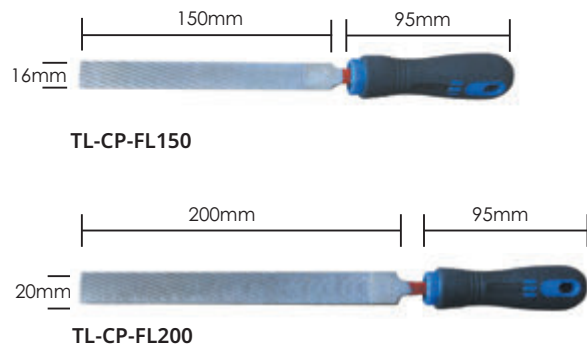
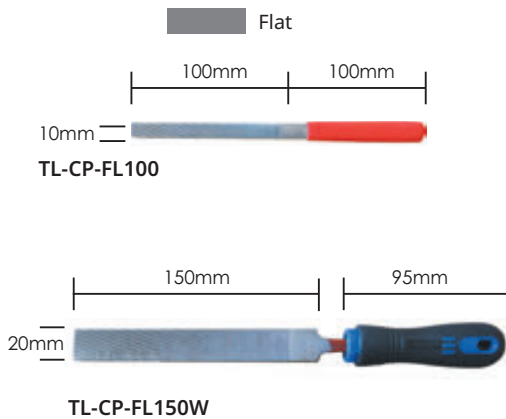

TL-CP-FL100	Flat / 100 x 10mm
TL-CP-FL150	Flat / 150 x 16mm
TL-CP-FL150W	Flat / 150 x 20mm
TL-CP-FL200	Flat / 200 x 20mm

### Half-round CP Files

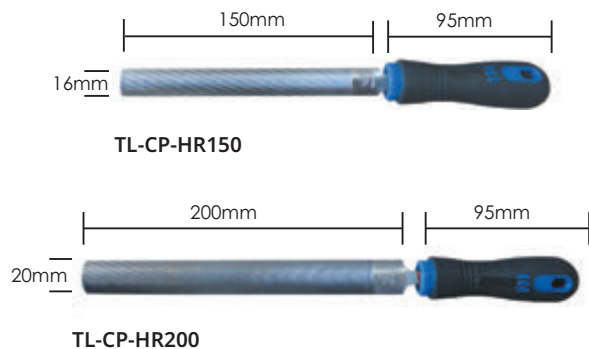
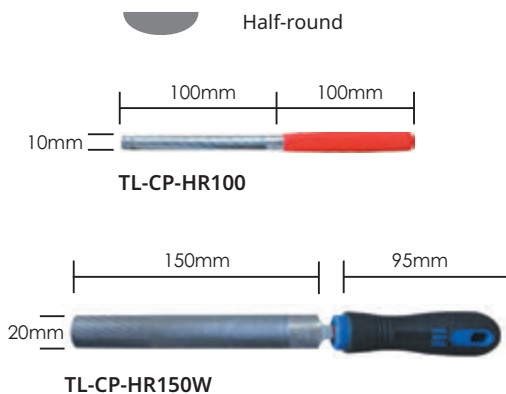

TL-CP-HR100	Half-round / 100 x 10mm
TL-CP-HR150	Half-round / 150 x 16mm
TL-CP-HR150W	Half-round / 150 x 20mm
TL-CP-HR200	Half-round / 200 x 20mm



# Wood Saw Rasps

The saw rasp is a unique tool which has properties for both saw and rasp. It isn't clogged because of the special shaped blades. The material is HCS (High Carbon Steel), so the durability of the blade is superior. These items have double sided blade which has coarse side and fine side. Suitable for any shaping task from rough to fine work. Your work will be from clogging!!!

TL-S-SR200



200mm long blade

TL-S-SR250



250mm long blade

TL-S-SRD-RB



Replacement blade for TL-S-SRD200



We only supply replacement blade from 2023.

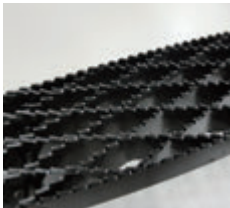

Coarse side

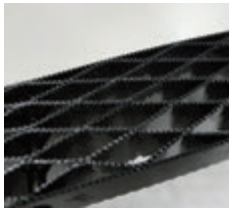

Fine side



TL-S-SR200

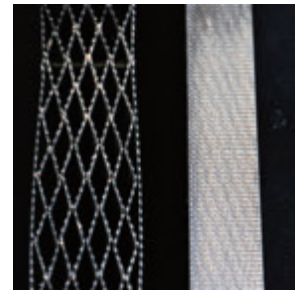

Saw Rasp

General

<a href="#">TL-S-SR200</a>	200mm long blade
<a href="#">TL-S-SR250</a>	250mm long blade
<a href="#">TL-S-SRD-RB</a>	Replacement blade for TL-S-SRD200

# Line Round Files



TL-BF5LR is a high-quality line round file set which has special coating to avoid clogging. And this non-clog coating promises fine cutting and long life. This file set works for string slot job for violin nut or bridge, violin peg holes cleaning etc. We sell each size is sold separately.

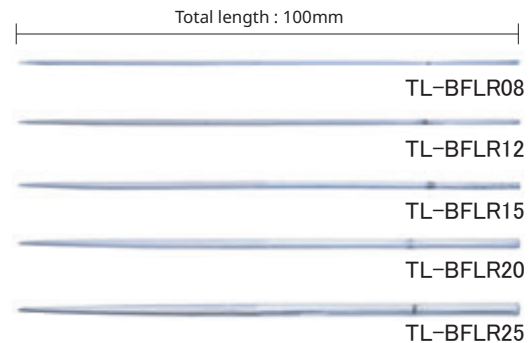

<a href="#">TL-BF5LR</a>	Set of 5 (0.8, 1.2, 1.5, 2.0, 2.5mm) , Non-Clog Coated Round
<a href="#">TL-BFLR08</a>	0.8mm, Non-Clog Coated Round
<a href="#">TL-BFLR12</a>	1.2mm, Non-Clog Coated Round
<a href="#">TL-BFLR15</a>	1.5mm, Non-Clog Coated Round
<a href="#">TL-BFLR20</a>	2.0mm, Non-Clog Coated Round
<a href="#">TL-BFLR25</a>	2.5mm, Non-Clog Coated Round

Nut & Saddle work	Head & Fingerboard work	Fret work	Saws, Knives, Chisels	Files, Sanding tools	Glue	Gauges	Fine Tuning	Workshop Gadget	Tool Caring	Violin Tools	Maintenance
-------------------	-------------------------	-----------	-----------------------	----------------------	------	--------	-------------	-----------------	-------------	--------------	-------------

## Feather Edge and Feather Edge Diamond Files

Feather edge and feather edge diamond files are usually used for sharpening hand saw, but these are useful for the first cut-in before nut slot filing.

### Feather Edge File

TL-DF100



Teeth per inch : 58 cut  
100mm Cut



Sharpening saw blades

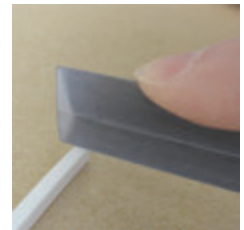

Marking for first-cut before nut slot making

TL-DF100	Edge File
----------	-----------

### Feather Edge Diamond Files

TL-DF75DA



300-grit Diamond, 75mm Cut

TL-DF100DA



300-grit Diamond, 100mm Cut



Good to make notches for strings on the metal saddles.

TL-DF75DA	Edge Diamond File, File length: 75mm
TL-DF100DA	Edge Diamond File, File length: 100mm

## Standard File Sets

Each file set includes 5 different shapes, Flat, Half-round, Round, Square and Triangle.



Flat      Half-round      Round      Square      Triangle



**TL-SFF5**  
Thickness : 1.5mm  
Flat : 1.5mm  
Half-round : 2.7mm  
Round : 3.4mm  
Square : 3.5mm  
Triangle : 5.5mm  
File length : 76.3mm  
Total length : 185mm



**TL-DIA5**  
Thickness : 1.5mm  
Flat : 1.5mm  
Half-round : 2mm  
Round : 2.7mm  
Square : 3mm  
Triangle : 3.5mm  
File length : 50.5mm  
Total length : 140mm



**TL-SSF5**  
Thickness : 1.5mm  
Flat : 1.5mm  
Half-round : 2.2mm  
Round : 3.5mm  
Square : 3.4mm  
Triangle : 4mm  
File length : 101mm  
Total length : 200mm

TL-DIA5	200-grit Diamond File Set
TL-SFF5	Secound cut File Set
TL-SSF5	Swiss-cut Precision Needle File Set

# Sanding Sheets

## SHINEX Sanding Sheets



Being clog-free and having the thickness that fits comfortably in your hand, the Sanding Sheet has better workability than sand paper. In addition, it provides an evenly finished surface without deep scratches. The Sanding Sheet is best suited for working on curved surfaces with its flexible structure. At the perforation in the center, it can be torn in half. It is usable in both water and oil.

### SSS-SET

2 of each grit (8 different grit, #80-#3000)  
16 sheets in total



Easy to cut in the center, because of a perforation



Sheet thickness is 7.5mm.

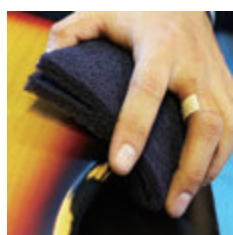

You can also finish like relic processing if you use this sanding sheet.

Size : 150x230x7.5mm (can cut half),



Before



After

SSS-SET	SHINEX Sanding Sheet Set 2 of each grit (80grit - 3000grit)
SSS-80	SHINEX Sanding Sheet 80grit
SSS-120	SHINEX Sanding Sheet 120grit
SSS-240	SHINEX Sanding Sheet 240grit
SSS-400	SHINEX Sanding Sheet 400grit
SSS-600	SHINEX Sanding Sheet 600grit
SSS-800	SHINEX Sanding Sheet 800grit
SSS-1500	SHINEX Sanding Sheet 1500grit
SSS-3000	SHINEX Sanding Sheet 3000grit

Nut & Saddle work

Head & Fingerboard work

Fret work

Saws, Knives, Chisels

Files, Sanding tools

Glue

Gauges

Fine Tuning

Workshop Gadget

Working tools

Tool Caring

Violin Tools Maintenance





## Kovax Rolled Sandpapers

This rolled sandpapers are self-adhesive and are suitable to use with TWSB series sanding blocks.

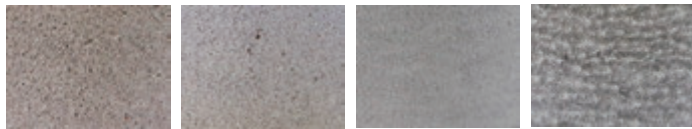

KCR100      KCR120      KCR150      KCR240



KCR320      KCR400      KCR600

KCR100	#100 / 64mm x 1.4m
KCR120	#120 / 64mm x 1.8m
KCR150	#150 / 64mm x 2.2m
KCR240	#240 / 64mm x 2.6m
KCR320	#320 / 64mm x 3.2m
KCR400	#400 / 64mm x 3.4m
KCR600	#600 / 64mm x 3.4m



## Self-adhesive Diamond Sheets



TDS100      TDS400

Suitable to use with our TWSB series sanding blocks.  
100-grit and 400-grit are available.  
Easy to cut by knife or scissors.



TDS100	#100 / 75 × 150mm
TDS400	#400 / 75 × 150mm

## Kovax Water Proof Sandpapers

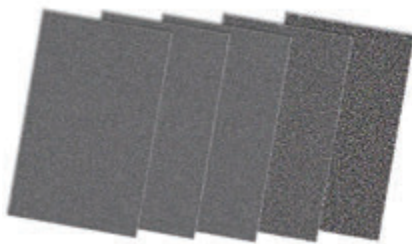

Standard water proof sandpapers for general wood works. 200pcs per box.

KSC180	#180 / 228 x 140mm	KSC800	#800 / 228 x 140mm
KSC240	#240 / 228 x 140mm	KSC1000	#1000 / 228 x 140mm
KSC320	#320 / 228 x 140mm	KSC1200	#1200 / 228 x 140mm
KSC400	#400 / 228 x 140mm	KSC1500	#1500 / 228 x 140mm
KSC600	#600 / 228 x 140mm	KSC2000	#2000 / 228 x 140mm

MOQ : 200pcs each

## Mini Self-adhesive Diamond Sheets



IDS-150



IDS-300



IDS-600



IDS-1200

The Mini Self-adhesive Diamond Sheets are now available in 4 different grits.  
The small size is good for ukulele or mandolin fret leveling work with sanding block.

Or any purpose for sanding or sharpening tools.

It is very flexible and easy to cut to any sizes.

IDS-150	#150 / 50 x 100mm
IDS-300	#300 / 50 x 100mm
IDS-600	#600 / 50 x 100mm
IDS-1200	#1200 / 50 x 100mm

Nut & Saddle work

Head & Fingerboard work

Fret work

Saws, Knives, Chisels

Files, Sanding tools  
Woodwork

Glue

Gauges

Fine Tuning  
Working tools

Workshop  
Gadget

Tool Caring

Violin Tools

Maintenance

## Sanding Blocks

### 2 Way Sanding Blocks



The Hosco original Wooden Sanding Blocks. Each block has 2 different radius on each sides as shown, helps you saving the space and cost.  
Save time of fret leveling or fingerboard job with our new Diamond sheets or Kovax self-adhesive sandpapers.



**TWSB-1**  
7-1/4" (184mm) / 9-1/2"(241mm)



**TWSB-2**  
10" (254mm) / 12"(305mm)



**TWSB-3**  
14" (356mm) / 16"(406mm)



**TWSB-4**  
15" (381mm) / 20"(508mm)



<a href="#">TWSB-1</a>	184R(7-1/4") / 241R(9-1/2") / Size : 80 x 150mm / Sanding area : 65 x 150mm
<a href="#">TWSB-2</a>	254R(10") / 305R(12") / Size : 80 x 150mm / Sanding area : 65 x 150mm
<a href="#">TWSB-3</a>	356R(14") / 406R(16") / Size : 80 x 150mm / Sanding area : 65 x 150mm
<a href="#">TWSB-4</a>	381R(15") / 508R(20") / Size : 80 x 150mm / Sanding area : 65 x 150mm

### Sanding Blocks for Ukuleles or Mandolins



Most of ukulele fingerboards are still flat, but nowadays radiused fingerboard is getting popular.

We developed two models with different radiuses.

One side is flat and the other side is radiused on both two models.

The flat side is also suitable to traditional mandolin fingerboards.

100mm(L) x 60mm(W) x 35mm(H) size fits ukulele and mandolin fingerboard work.



**TWSB-12U**  
12" (305mm) / Flat



**TWSB-16U**  
16" (406mm) / Flat



<a href="#">TWSB-12U</a>	305R (12") / flat
<a href="#">TWSB-16U</a>	406R (16") / flat

# Scrapers

The Wide Scrapers are useful for smoothing sides of guitars and they were developed by a Japanese famous classical guitar luthier's advice.

The Standard Scraper Set is used to wide surface like top and back of guitars.

The Shaped Small Scraper Set is especially designed for making violins.

## Wide Scrapers

TL-SCR-1C Thickness : 1mm

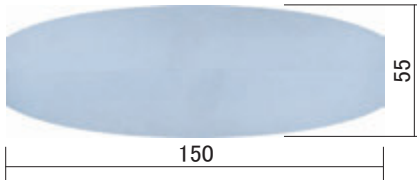

TL-SCR-1S Thickness : 1mm



TL-SCR-1C	150 x 55 x 1mm / Curved shape
TL-SCR-1S	150 x 55 x 1mm / Straight shape

## Standard Scraper Set

TL-SCR-2 Thickness : 0.4mm

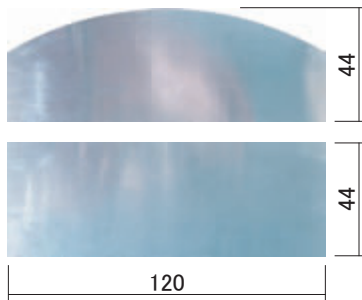

TL-SCR-2	Set of 2 shapes
----------	-----------------

## Shaped Small Scraper Set

TL-SCR-5

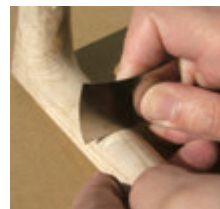
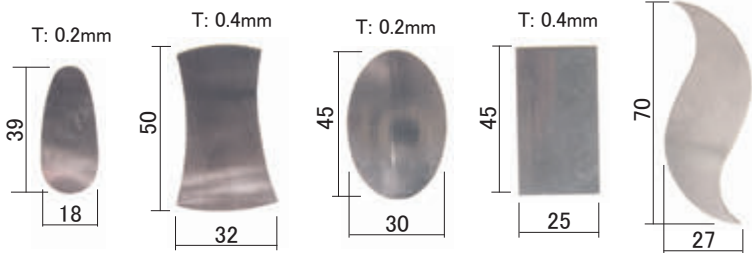

TL-SCR-5	Set of 5 shapes
----------	-----------------

Nut & Saddle work
Head & Fingerboard work
Fret work
Saws, Knives, Chisels
Files, Sanding tools
Woodwork
Glue
Gauges
Fine Tuning
Working tools
Workshop Gadget
Tool Caring
Violin Tools
Maintenance

## Hide Glue



膠  
ニカワ

### Japanese Hide Glue

High quality hide glue for musical instruments. (made in Japan)

Viscosity: 10.0 or more (mp)

Jelly strength: 280 or more (g)

PH: 6.50 - 8.50

Moisture: 16 or less (%)

Material: Cow skin



500g x2 for HG-H1S-1

This glue is specially produced for making musical instruments.

The strong point is its transparency and stable quality on the adhesive strength. Also, the specific smell is not as strong as general hide glue. Made in Japan.

The hide glue is packed in plastic bag except HG-H1S-25.

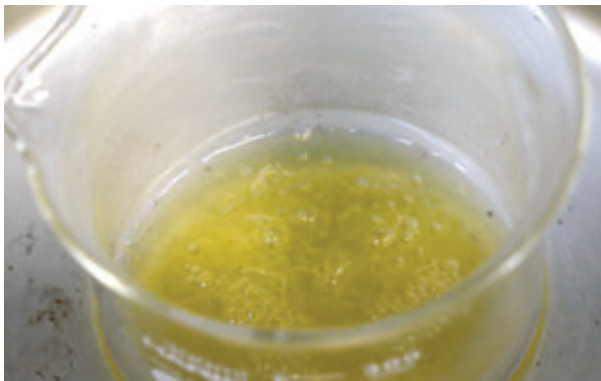

HG-H1S-05	500g
HG-H1S-1	1 kg (Set of 2 bags) *1 bag = 500 g
HG-H1S-5	5 kg (Set of 10 bags) *1 bag = 500 g
HG-H1S-25	25 kg in a paper bag



## HOW TO USE NIKAWA



1 Put a proper quantity of hide glue into a beaker.

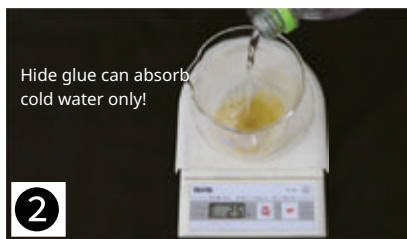

2 Then pour cold water into the beaker. Don't use warm water because the hide glue doesn't absorb water well.



3 In this sample, the mixing ratio of hide glue and water is about 1:3. We suggest making a little denser solution in order to dilute the density as you like later.



4 Leave the mixture as it is for about an hour for swelling.



5 Heat up the beaker in something like a pot at 70~80°C. If at the other temperature except it, the adhesive power will get weaker.



6 Melt the hide glue completely in stirring sometimes. Don't stir too much not to include some bubbles.



7 The density like the sample is good.



8 If the density is higher, dilute with warm water. Also if you dilute with cold water, the solution will be gelling.



9 You will get the target density by diluting little by little. And you should use the hide glue solution while it is warm.



Even if you had diluted too much, you must not add the hide glue into the solution. Because the dry hide glue does not melt in warm water.



Japanese Hide Glue  
"HOW TO USE NIKAWA"

## Binding Glue

The super glue for our bindings is available. One package is enough for one guitar. If there are oil, rubbish, and dust on an adhesion surface, please wipe off with solvent such as alcohol or acetone.



H-BG20AL

MOQ : 240 pcs  
Expiration Date : 2-3 years  
Please keep the glues in a dark and cool place.

### Important Notice:

Because of the product's properties, this glue can be shipped by ocean freight only. Please confirm rules and regulations for import to your country before you order.

H-BG20AL

Binding glue w/Aluminum packaging, 20 g

Nut &  
Saddle work

Head &  
Fingerboard  
work

Fretwork

Saws, Knives,  
Chisels

Files,  
Sanding tools  
Woodwork

Glue

Gauges

Working tools

Fine Tuning  
Gadget  
Workshop

Tool Caring

Violin Tools

Maintenance

## Step Gauges (Nut Slot Height / Fret Crown Height / String Action)



Step Gauge is an excellent gauge essential for checking the condition and adjusting fretted instruments such as guitars and ukuleles, combining three functions. (Made in Japan, patented)  
Anyone can check the nut string height, fret height, and string height in 0.1mm increments.

Recommended not only for manufacturers and stores, but also for everyone from repair workshops, guitar techs to guitar players.

Due to the characteristics of the product, the thickness is only 0.1mm, and it is a delicate gauge, so please handle it with care. A special case for storage is included.

### Guitar



### Ukulele



### Mandolin



Original case  
Aluminum thin case  
Size: 93 x 60 x 5mm



H-SG-G

### STEP GAUGE for Guitar

Size : 83 x 33 x 0.1mm  
Scale : Metric (mm/10) 1=0.1mm  
Material : Stainless steel  
for Acoustic, Classical, Electric guitars and Basses  
(scale length : approx. 600 - 900mm)



H-SG-U

### STEP GAUGE for Ukulele and Mandolin

Size : 85 x 36 x 0.1mm  
Scale : Metric (mm/10) 1=0.1mm  
Material : Stainless steel  
for Soprano, Concert and Tenor size ukuleles and mandolins  
(scale length : approx. 308 - 578mm)



H-SG-G	STEP GAUGE / for Guitar
H-SG-U	STEP GAUGE / for Ukulele and Mandolin

## How to use (H-SG-G)

### Fret Crown height



1) Set Step Gauge (Crown part) over a fret which you want to check.

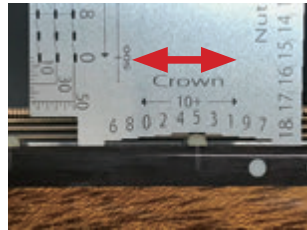

2) Slide the gauge to the right and the left to find the position fret crown top contacts the gauge.

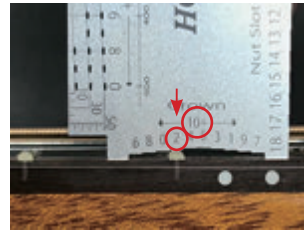

3) Read the number on the fret crown. Since the number is 10 times of mm. Divide it by 10.  
ex.  $10+2=12$ ,  $12/10=1.2\text{mm}$

### Tips!

Before nut slot work, you should check the 1st fret crown height. And then set up the target height of each string slot. You can check the height with our step gauge. ex. if the 1st fret height is 1.2mm, the target nut slot height is 1.3-1.4mm.

### Nut Slot height

1) Set Step Gauge (Nut Slot part) in the string slot which you want to check, and then put Step Gauge (2 legs) to contact a fingerboard.



2) Slide the gauge to headstock while keeping both legs contacting to fingerboard. Step Gauge stops when the gauge contacts nut slot.

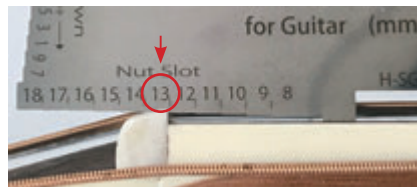

3) Read the number on the nut. Since the number is 10 times of mm. Divide it by 10.  
ex.  $13$ ,  $13/10=1.3\text{mm}$



Caution! : If the leg is floating off fingerboard, Slide back the gauge until both legs contact the fingerboard again.

### String Action

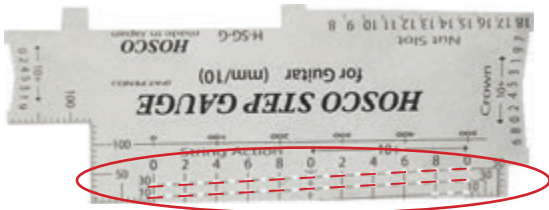

There are many slits at string action gauge area in 2 lines. Lower line shows you from 1.0mm to 3.0mm height. Upper line shows you from 3.0mm to 5.0mm height. Each slit locates 0.1mm height gap.



1) Set Step Gauge (String Action part) at the position which you want to check on the fingerboard. just set it behind the string.

2) Slide the gauge to the right and the left to find the position that the string bottom covers a slit.

Tips : with light from other side, you can see the slit hole clearly.

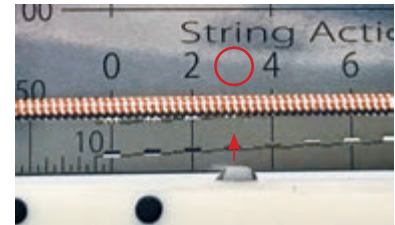

3) Read the number. Since the number is 10 times of mm. Divide it by 10.

ex. the slit is between 2 and 4. And higher line slit contacts the string. So  $30+3=33$   $33/10=3.3\text{mm}$

### Other function

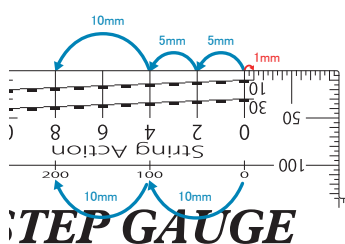

String action gauge is also regular metric scale. You can check nut width or saddle slot depth, pickup polepiece distance etc. (This function is only for H-SG-G)

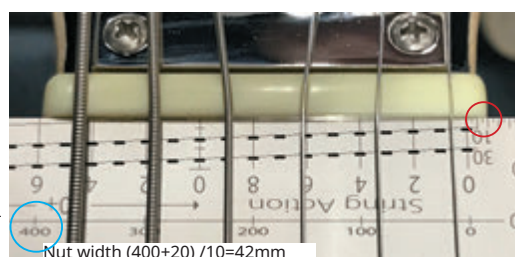

H-SG-G



H-SG-U

Nut & Saddle work

Head & Fingerboard work

Fretwork

Saws, Knives, Chisels

Files, Sanding tools

Glue

Gauges

Fine Tuning

Workshop Gadget

Tool Caring

Violin Tools

Maintenance



# Gauges

## Fingerboard Radius Gauge

Hosco new Fingerboard Radius Gauge not only checks the six major fingerboard radius, it also has a gauge to check the fret height in 0.1mm pitch.

210mm x 25mm size with hanging hole. Easy to keep in your workshop or in your tool box. It is a real "must-have" item!

\*Made of stainless steel

H-RG2



Back side

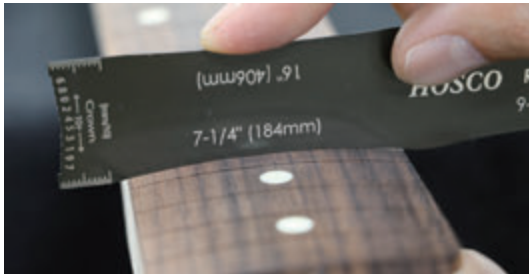

Radius Gauge

- 7-1/4" (184mm)
- 9-1/2" (241mm)
- 10" (254mm)
- 12" (305mm)
- 14" (356mm)
- 16" (406mm)



Fret crown height gauging (mm/10)  
This is same function as Step Gauge (see page 41).



Low Fret area      High Fret area  
Fret Crown height

H-RG2	R-gauge
-------	---------

## Rulers w/ Inch Conversion Table



TL-RU600      600mm



TL-RU300      300mm



TL-RU150      150mm

Scale marks are done by etching and black chrome plating.  
And Inch - mm conversion chart is printed on the back.  
Each scale has a hanging hole.

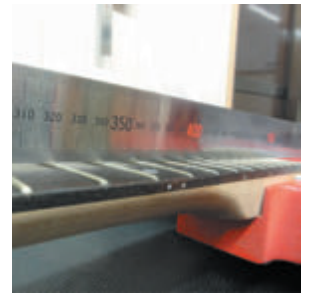

600mm size rule is good for guitar neck checking.

TL-RU600	600mm
TL-RU300	300mm
TL-RU150	150mm

## Protractor



TL-RU-PR



Suitable to check a neck angle

TL-RU-PR	protractor w/ 100mm ruler
----------	---------------------------



## Taper Gauge



TL-RU-TA



Taper gauge is easy to check the hole diameter.

compensation formula to check inner diameter

$$\text{Inner diameter} = \text{value2} + 1.44$$

Taper gauge works to check the inner hole diameter easily. Just insert this gauge into the hole and read the number of the gauge. Metric scale.

You can check 1mm up to 15mm inner hole diameter.

TL-RU-TA

1.2mm thickness, 1 -15mm diameter hole

## Mini Stainless Square

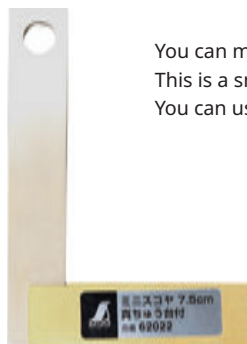

TL-RU-SQ75

You can measure an angle of 90 degrees exactly. This is a small tool, but a pretty convenient one. You can use it variously like the following examples.



Checking flatness for installing machine heads

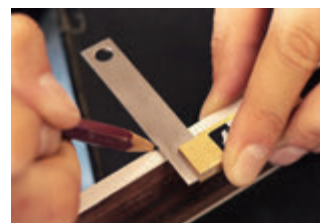

Marking for side position.

TL-RU-SQ75

Blade: Stainless Steel (75x13x1.5mm), Base: Brass (48x15x6.0mm), Net Weight: 45g

## Profiling Gauge



TL-RU-PG

This unique profiling gauge can work to check the neck shape or others.

Many movable pins in line makes its shape well.

Note : Pins may damage to the neck or surface.

Please protect the instruments or others before using.

\*Made of stainless steel



example: for neck shapes

TL-RU-PG

150mm Length, Profiling the Shape, Needle size : 84 mm x 0.8mm diameter

## Thickness Gauge



TL-RU-TG



Checking a relief of the neck



9 different thickness gauge in one. 0.04mm up to 0.30mm.

Metal frame case protect thinner gauges from damage.

TL-RU-TG

Material : carbon steel, Thickness variation : 0.04 / 0.05 / 0.06 / 0.07 / 0.08 / 0.10 / 0.15 / 0.20 / 0.30 (mm)

Nut & Saddle work

Head & Fingerboard work

Fret work

Saws, Knives, Chisels

Files, Sanding tools Woodwork

Glue

Gauges

Working tools

Fine Tuning

Workshop Gadget

Tool Caring

Violin Tools

Maintenance

# Fine Tuning

## Guitar Nut Cube (5 in 1 wrench)

The H-GNC can be used to tighten or loosen nuts or bushing for machine heads, toggle switches, potentiometers, and so on. Cube can be inserted under volume or tone knobs easily.



**H-GNC**  
HOSCO original design.

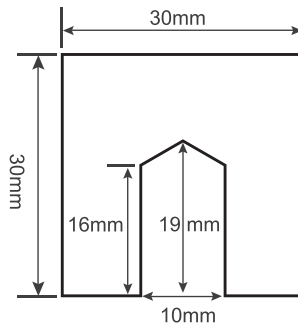

**10mm Hex Nut**

Gotoh® or other guitar tuner hex nut etc.  
Use GNC after loosening strings or remove strings.

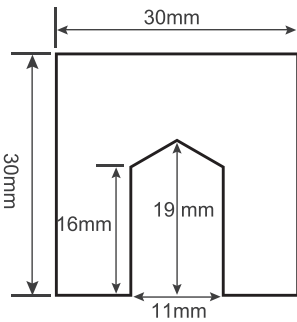

**11mm Hex Nut**

Japanese potentiometers, Push-Pull control pots etc.

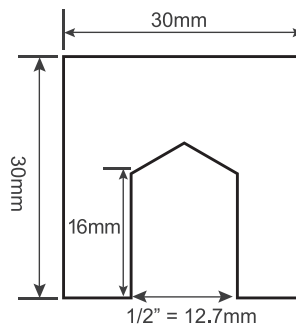

**1/2" Hex Nut**

USA potentiometers etc.

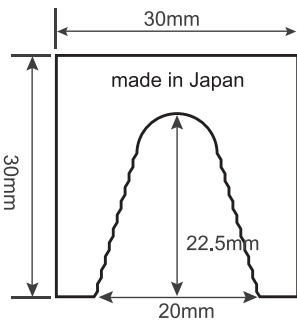

**Multi Knurled Nut (USA or others)**

USA toggle switches or TOM nut etc.

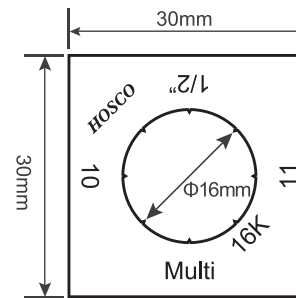

**16mm Knurled Nut**

Japanese toggle switches etc.



H-GNC	Guitar Nut Cube(5 in 1 Wrench) / Stainless steel, made in Japan.
-------	--

# Wrenches

## Hex Wrenches



<a href="#">WRE-1.27J</a>	Allen Wrench / 1.27mm (.050") / for Saddle height adjustment on tremolo (Inch)
<a href="#">WRE-1.5J</a>	Allen Wrench / 1.5mm / for Saddle height adjustment on tremolo (Metric)
<a href="#">WRE-1.57J</a>	Allen Wrench / 1.57mm (1/16") / for Bass saddles, JB knobs (Inch)
<a href="#">WRE-2.0J</a>	Allen Wrench / 2.0mm / for GOTOH® VS100N saddles, knobs
<a href="#">WRE-2.5J</a>	Allen Wrench / 2.5mm / for Floyd Rose® saddle fixing screws
<a href="#">WRE-3.0J</a>	Allen Wrench / 3.0mm / for Floyd Rose® stud height adjustment
<a href="#">WRE-4.0J</a>	Allen Wrench / 4.0mm / for Truss rod nut
<a href="#">WRE-5.0J</a>	Allen Wrench / 5.0mm / for Truss rod nut

## Truss Rod Wrenches

### Phillips Head Truss Rod Wrench

It is the final solution to adjust a traditional slotted truss rod nut with "+" shape wrench not "-" shape.

We design only 11mm short length x 9mm diameter head to use the wrench without taking off the neck.

"+" shape can catch the slotted nut perfectly and disperse turning torque evenly.

It is the "must-buy" tool for guitar set up.



<a href="#">H-TRW+</a>	Phillips Head Truss Rod Wrench
------------------------	--------------------------------

## Pipe Wrenches



Inch type wrenches are available in 2 sizes, 1/4" and 5/16". 5/16" wrench is with phillips head.

<a href="#">WRE-7.0J</a>	7.0mm
<a href="#">WRE-8.0J</a>	8.0mm
<a href="#">WRE-I14J</a>	1/4" (6.35mm)
<a href="#">WRE-I516J</a>	5/16" (7.93mm)

## Hex Wrenches



<a href="#">WRE-4.0J</a>	Allen Wrench / 4.0mm
<a href="#">WRE-5.0J</a>	Allen Wrench / 5.0mm

Nut & Saddle work  
Head & Fingerboard work  
Fretwork  
Saws, Knives, Chisels  
Files, Sanding tools  
Glue  
Gauges  
Fine Tuning  
Workshop Gadget  
Tool Caring  
Violin Tools  
Maintenance

## 2-way Neck Support

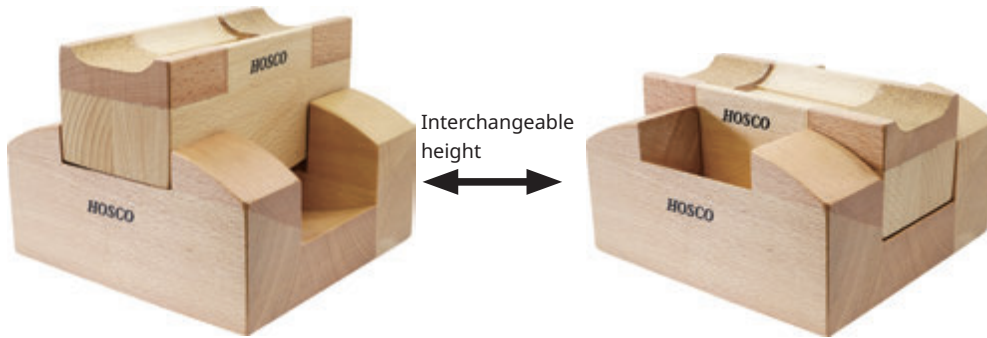

HOSCO original wooden neck support consists of 2 parts as pictured, which you can get two different height at the neck rest. The top part is cork lined to protect the neck, and swinging on the bottom.



High position (H : 10.5cm)  
(ex : for acoustic guitars)

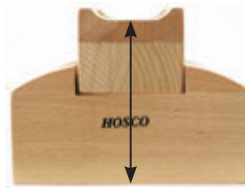

10.5cm

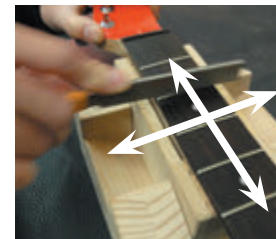

H-NSG gives you a good stability not only fret leveling job direction, but also fret crowning job direction.



Low position (H : 7.5cm)  
(ex : for electric guitars)

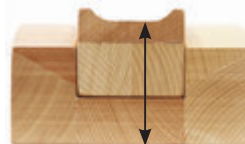

7.5cm



Soprano



Concert



Tenor



You can support thin instruments such as Ukuleles with only the top part.

H-NSG

for Acoustic Guitars, for Electric Guitars, for Ukulele, for Mandolin, for Banjo etc...

## Workbench Mat

HOSCO Workbench Mat is made of PVC cover, PE foam 5mm thickness at the inside, and featuring Non slip PVC at the back side. 6cm (2-1/4") width of front edge is able to fold down at the edge of the bench. Secure magnets are located at two corners of upper side to hold metal parts such as screws, nuts, small hardwares, etc.. This is really ideal mat for every luthier.

H-LWM1

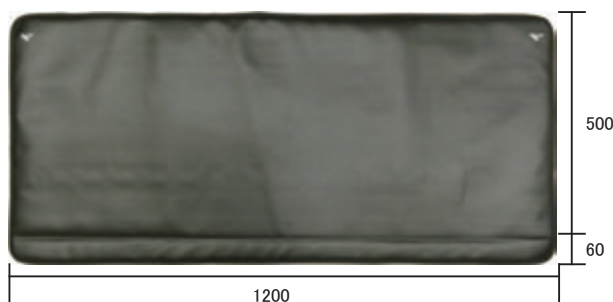

6cm wide extra part for protector



Magnets are put on the inside of both edges.

H-LWM1

Size : 120cm x 50cm (47" x 19-3/4")



# HOSCO Work Apron



H-AP1

This is HOSCO original apron with two pockets and two pen-pockets, made of Canvas cloth. Long tie and waist straps are adjustable to fit your style. Embroidered HOSCO logo with white thread Logo on the front.



H-AP1

Free size / canvas cloth / Weight : 360g

# Tool Bags

## Roll-up to Tool Bag

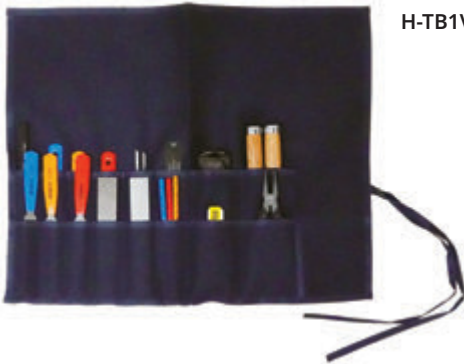

H-TB1V

This tool bag is Japanese traditional tool bag. We designed 2 different height pockets, so you can insert short or long tools. Material : navy canvas cotton.

Size : 500mm x 400mm / Weight : 130g

Pocket : 30mm(W) x 110mm/170mm(H) x 3  
40mm(W) x 110mm/170mm(H) x 3  
70mm(W) x 110mm/170mm(H) x 2  
Total 16 pockets

\* Please note that the roll-up bag does not come with these tools. The photos are for illustrative purposes only.

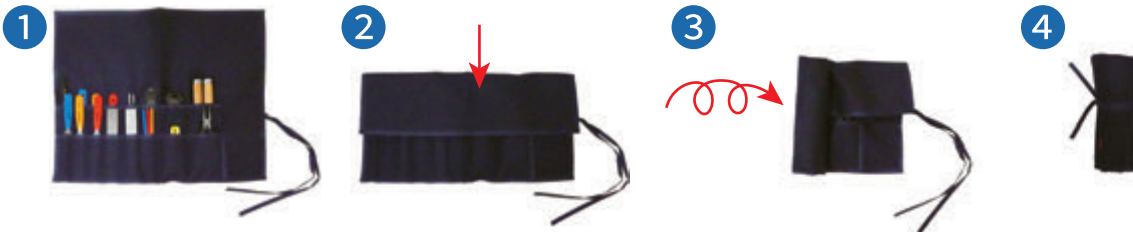

## Guitar Tech Bag



H-TB2

Compact and #1680D black nylon zipper bag with handle is developed for guitar techs.



This transparent compartment can be used to put some small parts or small tools. You can see easily what is inside.

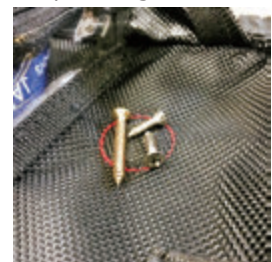

A magnet is attached under the red circle. You can use the magnet to put small parts like screws, nuts, and washers not to lose them while you are working.

- \*6 inserts with rubber bands for nut /fret files or gauges etc, screwdrivers etc.
- \*One transparent PVC zipper pocket for small parts or tools like hex wrenches
- \*One screw catcher magnet with red thread circle.

<b>NEW</b> H-TB1V	Roll-up tool bag / Size : 500 x 400mm / Weight : 130g
H-TB2	Guitar Tech Bag / Size : 220 x 120 x 70mm / Weight : 125g

Nut & Saddle work	Head & Fingerboard work	Fretwork	Saws, Knives, Chisels	Files, Sanding tools	Glue	Gauges	Fine Tuning	Workshop Gadget	Tool Caring	Violin Tools	Maintenance
-------------------	-------------------------	----------	-----------------------	----------------------	------	--------	-------------	-----------------	-------------	--------------	-------------

## Ceramic Stones

### Ceramic Combination Stones



Our ceramic stones are made by mixing superfine compound and clayey binder and then high-temperature firing.

These ceramic stones are combination type with case which can be used for sharpening table and water pond. You can keep the bottom side stone into water. Wet Stone Size : 183×63×13 / 183×63×15mm

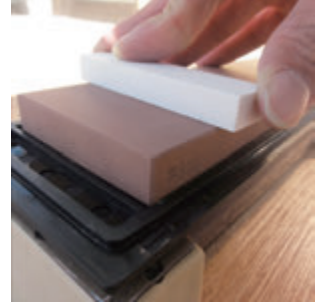

This is a flattening stone for worn shaprening stone which you used. Put it into water and then use it.

This is an artificial NAGURA stone. Because of shaping by machine cut, its edge or corner may be lack or tipped off a little bit, but it is useful for flattening job.



TL-NC1800C #320 / #800



TL-NC2800C #280 / #1500



TL-NC3800C #1000 / #3000



TL-NC4800C #1000 / #6000

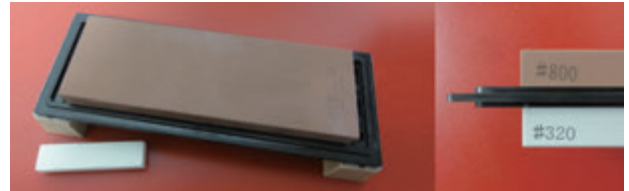

TL-NC1800C	NEW CERAX COMBINATION STONE #320/#800
TL-NC2800C	NEW CERAX COMBINATION STONE #280/#1500
TL-NC3800C	NEW CERAX COMBINATION STONE #1000/#3000
TL-NC4800C	NEW CERAX COMBINATION STONE #1000/#6000

### Ceramic Single Stones

For these single stones, soak the stones in water for 10 to 15 minutes before use.

Size : 206x66x33.5mm



TL-ST800  
#800



TL-ST1200  
#1200

TL-ST800	SPLEX CERAMIC STONE #800
TL-ST1200	SPLEX CERAMIC STONE #1200

# Diamond Hones

## Table-top type Diamond Hones

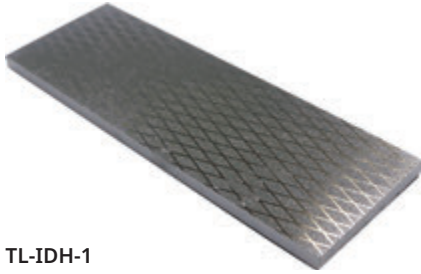

TL-IDH-1

This product works for honing of chisels or knives.  
 Rubber grip sheet on the bottom.  
 Size: 205 x 70mm Weight: 1 kg



TL-IDH-1  
Coarse 150-grit



TL-IDH-2  
Medium 300-grit



TL-IDH-3  
Fine 800-grit

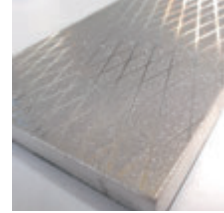

Enlargement

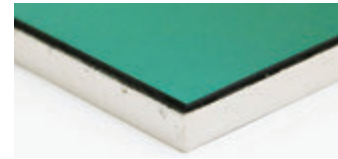

Rubber grip sheet on the back side

TL-IDH-1	Diamond Honing Tools #150
TL-IDH-2	Diamond Honing Tools #300
TL-IDH-3	Diamond Honing Tools #600

## Handy-type Dual Grit Diamond Plates

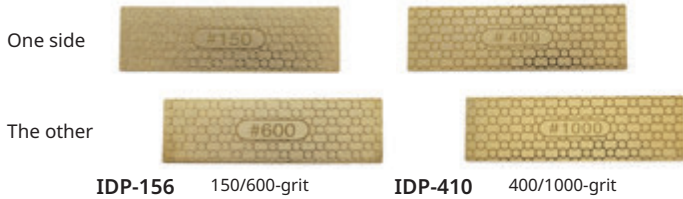

One side

The other

IDP-156

150/600-grit

IDP-410

400/1000-grit

Compact and reasonable diamond honing tools.  
 Two combination of the grits are available.  
 Good for leveling and beveling frets, and also shaping bone nuts and saddles.  
 Size: 30 x 100mm / Thickness : 1mm

IDP-156	#150 / 600, Dual Grit Mini Diamond Plates
IDP-410	#400 / 1000, Dual Grit Mini Diamond Plates

# Tool Maintenance Oil



H-TO-15

H-TO-15 HOSCO Tool Oil provides various uses and better condition.



**Reduce friction in filing and sawing operations**

It reduces friction between the file and the nut.  
 You can make finer nut slot adjustments with less force.



**For lubricating the pivot point of pliers**

Lubricate the pivot point of the plier with H-TO-15 for smooth movement.  
 You can use the plier for the long time with non-stressful and a light touch.



**High rust-preventive effect**

A thin coating of H-TO-15 provides a long-lasting high rust-preventive effect.



Click here for explanation video.

It meets air safety regulations and can be transported by air .  
 We can provide the SDS (Safety Data Sheet).

NEW	H-TO-15	HOSCO Tool Oil
-----	---------	----------------

Nut & Saddle work  
 Head & Fingerboard work  
 Fretwork  
 Saws, Knives, Chisels  
 Files, Sanding tools  
 Woodwork  
 Glue  
 Gauges  
 Working tools  
 Fine Tuning  
 Workshop  
 Gadget  
 Tool Caring  
 Violin Tools  
 Maintenance

## Violin Nut Files

### Violin Nut Files

These nut files are designed for filing the slots for strings of violins. It brings accurate works. The set comes with a plastic cylinder case.

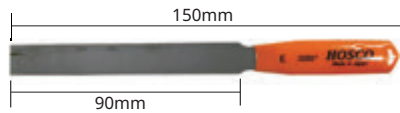

Teeth per inch : 76 cut (for E, A, and D strings)  
Teeth per inch : 78 cut (for G string)

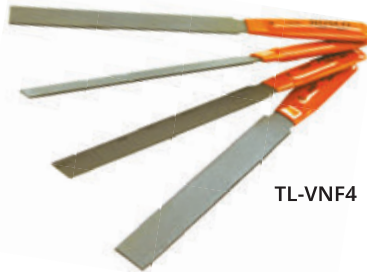

TL-VNF4



TL-VNF4	Edge-Cut Violin Nut Files Set of 4 ( E .020", A .026", D .032", G .040")
TL-VNF4/E	Edge-Cut Violin Nut File for E string

### Line Round Files



TL-BF5LR

TL-BF5LR is a high-quality line round file set which has special coating to avoid clogging. And this non-clog coating promises fine cutting and long life. This file set works for string slot job for violin nut or bridge, violin peg holes cleaning etc. We sell each size is sold separately.



TL-BF5LR	Set of 5 (0.8, 1.2, 1.5, 2.0, 2.5mm) , Non-Clog Coated Round / Total length : 100mm
----------	---

## Peghole Saw / Hand Jig Saw

TL-H-VP



It is useful for cutting inside of violin pegbox.



TL-H-VP	Hand Jig(Peg Hole)Saw / Blade Length : 70mm
---------	---

## Kujiri (Eyeleteer) and Micro Chisels



TL-KUJIRI-S

Please check Page 39 for the detail.



TL-MC11

TL-MC22



TL-KUJIRI-S	Kujiri(Eyeleteer) / Material : Stainless
TL-MC11	Micro Chisel / Width : 1.1mm / Material : Stainless Steel
TL-MC22	Micro Chisel / Width : 2.2mm / Material : Stainless Steel



# Japanese Gouges

Blade material is "Shiragami" white steel and HRC64. Total length : 180mm

TL-IGS9



Spoon Shape 9mm wide Blade

TL-IGS15



Spoon Shape 15mm wide Blade



Side view



TL-IGS15 blade

TL-IGS9	9mm wide Blade
TL-IGS15	15mm wide Blade

# Knives

## "Kuri" Knives with Special Wooden Handle

TL-I-KUKR



TL-I-KUKD



TL-I-KUKL



Right Bevel

Left Bevel

Double Bevel

It is same as Kiridashi knife but its pointed head allows you to process the places where you are unable to process by Kiridashi knives, such as a hole, a corner, a ditch and inside of a circle.

The original shaped handle brings nicer grip feeling.

13.5mm width blade, with wooden handle type

Wooden handle length : 139mm.

TL-I-KUKR	Right
TL-I-KUKL	Left
TL-I-KUKD	Double

# Hide Glue



HG-H1S-05

This glue is specially produced for making musical instruments.

The strong point is its transparency and stable quality on the adhesive strength. Also, the specific smell is not as strong as general hide glue. Made in Japan.

Packed in plastic bags except HG-H1S-25.

HG-H1S-05	500g
HG-H1S-1	1 kg (Set of 2 bags) *1 bag = 500 g
HG-H1S-5	5 kg (Set of 10 bags) *1 bag = 500 g
HG-H1S-25	25 kg in a paper bag

# Scrapers

## The Standard Scraper Set

The Standard Scraper Set is used to wide surface.

TL-SCR-2 0.4mm Thickness

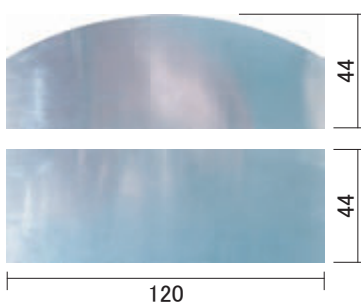

## The Shaped Small Scraper Set

The Shaped Small Scraper Set is especially designed for making violins.

TL-SCR-5 Shaped Small Scraper Set

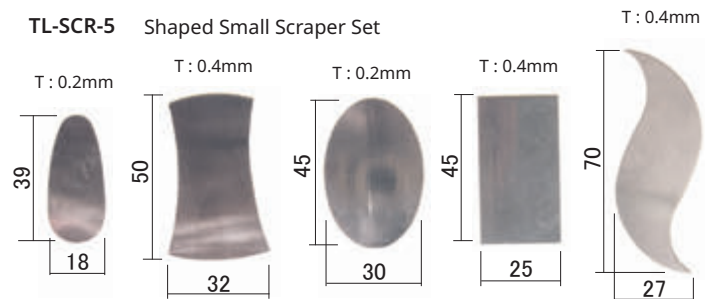

TL-SCR-2	Set of 2 shapes / Thickness : 0.4mm
TL-SCR-5	Set of 5 shapes

Nut & Saddle work

Head & Fingerboard work

Fretwork

Saws, Knives, Chisels

Files, Sanding tools

Glue

Gauges

Fine Tuning

Workshop Gadget

Tool Caring

Violin Tools

Maintenance

## EASY FRET CARE

Easy Fret Care is a set of cloths and fretboard protection sheets developed for end-users to easily polish frets. 3 sheets of protection sheets can be used for one guitar.

### Package Set

includes 2 x Fret Care Cloth and 5 x Fret Care Sheet with case



H-EFC-S20 2.0mm width for Small Fret

H-EFC-S24 2.4mm width for Medium Fret

H-EFC-S28 2.8mm width for Jumbo Fret

### Refill Pack

includes 2 x Fret Care Cloth and 5 x Fret Care Sheet without case



H-EFC-R20 2.0mm width for Small Fret

H-EFC-R24 2.4mm width for Medium Fret

H-EFC-R28 2.8mm width for Jumbo Fret

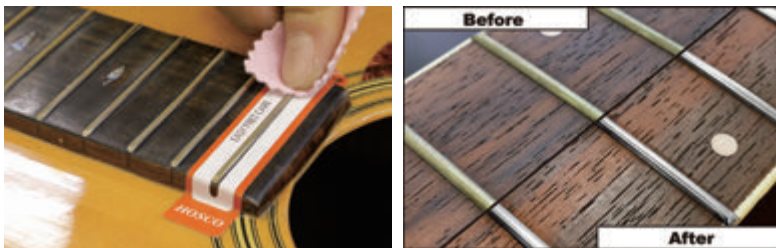

Check "How to use" movie.

### How to use

1. Wipe the fingerboard and remove the dusts by common cloth first.
2. Take a piece of care sheet and put it to cover the fingerboard to show the fret.
3. Polish the fret by care cloth.
4. When polished it, remove the care sheet and put it on the next fret.
5. Polish the next fret in the same way.
6. When you feel the care sheet glue gets weak, change to a new one.



How quickly EASY FRET CARE can polish frets !

H-EFC-S20	EASY FRET CARE / for Small size fret
H-EFC-S24	EASY FRET CARE / for Medium size fret
H-EFC-S28	EASY FRET CARE / for Jumbo size fret
H-EFC-R20	EASY FRET CARE / for Small size fret / Refill Pack
H-EFC-R24	EASY FRET CARE / for Medium size fret / Refill Pack
H-EFC-R28	EASY FRET CARE / for Jumbo size fret / Refill Pack

# Wiping Clothes

## HOSCO Ezo-deer Chamois cloth Made in Japan



HCL-100S

This chamois leather is made of Ezo-deer Chamois captured as a forest protection measure in Hokkaido. We have begun to introduce this environmentally friendly product overseas in addition to its domestic release in Japan.

Ezo-deer Chamois is chamois-tanned wild deer leather. Therefore, there may be scratches or holes left on the product from fights, but this is a sign of authenticity and does not affect the quality.

### <Ezo-deer Chamois story>

More than 100,000 Ezo-deer are captured annually due to population adjustments in Hokkaido's Ezo-deer conservation management plan.

It is true that the use of wild animal resources can lead to overhunting if not done carefully, but since they are captured with adjustments, the disposal of parts other than meat after mass capture is more problematic than such concerns at this time, and not using them is far more pitiful than refraining from using them.

The fiber structure of Ezo-deer skin was not as good as that of other deer family.

Therefore, we introduced the deerskin "nameshi" technique, a traditional industry in Nara, and after repeated trial and error, we brought out the thin and soft texture of Ezo deer skin and "Ezo-Deer Chamois" was born.

<b>NEW</b>	<a href="#">HCL-100S</a>	HOSCO Ezo-deer Chamois cloth / Small / 30x30cm
<b>NEW</b>	<a href="#">HCL-150M</a>	HOSCO Ezo-deer Chamois cloth / Medium / 35x40cm

## Professional Care Cloth for superior finish



HWC-3739



Package

This wiping cloth for musical instruments is made from thick microfiber and has both a good touch and durability. The antistatic material keeps dust away from the cloth even in dry weather and places, and it can be used both dry and wet, so it can be used for various instruments such as wind instruments and pianos, in as well as guitars.



Click here for explanation video.

<b>NEW</b>	<a href="#">HWC-3739</a>	Professional Care Cloth for superior finish / 37 x 39cm
------------	--------------------------	---

Nut & Saddle work

Head & Fingerboard work

Fret work

Saws, Knives, Chisels

Files, Sanding tools

Glue

Gauges

Fine Tuning

Workshop Gadget

Tool Caring

Violin Tools

Maintenance

## Humidity Control Items

### Fret Shield

Fret Shield has two functions: reducing damage to the frets and controlling humidity inside the case! It's easy to use, just insert it between the strings and the fingerboard of your guitar.

Just put it in the case as it is, and it will keep the inside of the case at the right humidity level, and also prevent scratches and dents on the frets that can occur when the instrument is moved around in the case and the frets and strings hit or rub against each other.

AHM-530



□Material□  
Surface fabric: Polypropylene  
Humidity regulator (content): B-type silica gel

AHM-660

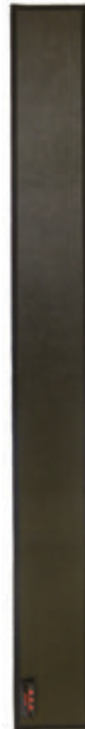

When used on acoustic guitars, it can also be dripped inside the sound hole for humidity control inside the body!



[Click here for explanation video.](#)

<a href="#">AHM-530</a>	Fret Shield / for Ukulele, for Mandolin / 5 × 30cm
<a href="#">AHM-660</a>	Fret Shield / for Guitar, for Bass / 6 × 60cm



# Hygrometer / Thermometer

HOSCO Hygrometer / Thermometer is useful just as the indicator, also it's the best tool to catch the condition of your instrument if you mount in your guitar case with our optional mount kit. Also, the H-HT60/L can be used as an interior parts in your workshop.

**H-HT60**  
HOSCO Hygrometer/ Thermometer



**H-HT60F**  
Fahrenheit version



## Features

- \* Japan high quality mechanism, called "EX sensor" installed.
- \* Tolerance: +-3% for hygrometer and +- 2 degree for Thermometer.
- \* 62mm outer diameter x 19mm thickness.
- \* Black face design fits for guitar case or musician's room.
- \* Fahrenheit thermometer is also available.
- \* Made in Japan

**H-HT60/L**  
Tabletop type



wall-hanging type

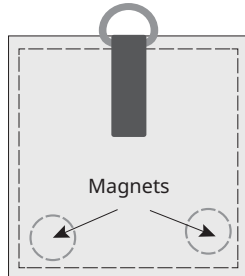

With the leather case, it can be assembled into a tabletop type, a wall-hanging type by hooking the ring attached to the back of the case to a hook or the like, or it can be attached to a metal panel or the like with the magnets on the back of the case.

**H-HT60/M**  
HOSCO Hygrometer / Thermometer includes case mount kit (refer HT-MKIT)



**HT-MKIT**  
Case mount kit only  
Plate x 1  
Velcro x 1  
Screw x 2



## How to use (Mount Kit)



1. Fix the plate to the hygrometer with 2 screws.



2. Insert the plate under the case pocket wall.



3. Slide in and adjust the position of plate till the hygrometer can be seen clearly.



4. Set the velcro tape under the plate. This is for non-slip purpose. The hook side should be at the bottom to catch the case interior.

<b>H-HT60</b>	HOSCO Hygrometer / Thermometer
<b>H-HT60F</b>	HOSCO Hygrometer / Thermometer Fahrenheit version
<b>H-HT60/L</b>	HOSCO Hygrometer / Thermometer set with foldable black leather frame
<b>H-HT60/M</b>	HOSCO Hygrometer / Thermometer includes case mount kit (refer HT-MKIT)
<b>HT-MKIT</b>	HOSCO Hygrometer / Thermometer Case mount kit only

Nut & Saddle work	Head & Fingerboard work	Fretwork	Saws, Knives, Chisels	Files, Sanding tools	Glue	Gauges	Fine Tuning	Workshop Gadget
			Woodwork				Working tools	

Tool Caring

Violin Tools

Maintenance

# Alphabetical Index

## A

AHM-530	Fret Shield for Ukulele, for Mandolin .....	56
AHM-660	Fret Shield for Guitar, for Bass.....	56

## F

FPR180	Fret Polishing Rubber / #180 .....	21
FPR400	Fret Polishing Rubber / #400 .....	21
FPR1000	Fret Polishing Rubber / #1000 .....	21
FPR-SET-3	Fret Polishing Set .....	21
FPR-SET-4	Fret Polishing & Sanding Rubber Set .....	21
FSR150	Fret Sanding Rubber .....	21

## H

H-AP1	HOSCO Work Apron .....	49
H-BG20AL	Binding Glue .....	41
HCL-100S	HOSCO Ezo-deer Chamois cloth / Small .....	55
HCL-150M	HOSCO Ezo-deer Chamois cloth / Medium .....	55
H-EFC-S20	EASY FRET CARE for Small size fret.....	54
H-EFC-S24	EASY FRET CARE for Medium size fret .....	54
H-EFC-S28	EASY FRET CARE for Jumbo size fret .....	54
H-EFC-R20	EASY FRET CARE for Small,Refill Pack .....	54
H-EFC-R24	EASY FRET CARE for Medium,Refill Pack .....	54
H-EFC-R28	EASY FRET CARE for Jumbo,Refill Pack .....	54
H-FF1	Compact Fret Crown File / Small .....	24
H-FF2	Compact Fret Crown File / Medium .....	24
H-FF2HC	Compact Fret Crown File for Stainless / Medium .....	24
H-FF3	Compact Fret Crown File / Large .....	24
H-FF3HC	Compact Fret Crown File for Stainless / Large .....	24
H-FF-UFO1	Ultimate Fret Crown Optimizer 1 .....	25
H-FF-UFO2	Ultimate Fret Crown Optimizer 2 .....	25
H-FSWG	Fret Slot Saw Guide .....	15
H-FSWG-PG	Fret Slot Saw Guide Polyacetal guide only.....	15
H-FTN-J	Fret Tang Nippers for Jumbo frets .....	19
H-FTN-M	Fret Tang Nippers for Medium frets .....	19
H-GB-042	GrooBar™ / Set of 4 L2=0.042" (1.07mm) .....	7
H-GB-050	GrooBar™ / Set of 4 L1=0.050" (1.27mm) .....	7
H-GB4	GrooBar™ / for Guitar .....	7
H-GB4U	GrooBar™ / for Ukulele .....	7
HG-H1S-05	Hide Glue / 500g .....	40, 53
HG-H1S-1	Hide Glue / 1kg .....	40, 53
HG-H1S-25	Hide Glue / 5kg .....	40, 53
HG-H1S-5	Hide Glue / 25kg .....	40, 53
H-GNC	Guitar Nut Cube .....	46
H-HT60	HOSCO Hygrometer / Thermometer.....	57
H-HT60/L	HOSCO Hygrometer / Thermometer set .....	57
H-HT60/M	Hygrometer / Thermometer w/ case mount kit .....	57
H-HT60F	Hygrometer / Thermometer Fahrenheit version .....	57
H-LWM1	Workbench Mat .....	48

H-MASKT-12B	Low Tack Masking Tapes / 12mm width, Box .....	16
H-MASKT-12P	Low Tack Masking Tapes / 12mm width, Pack .....	16
H-MASKT-20B	Low Tack Masking Tapes / 20mm width, Box .....	16
H-MASKT-20P	Low Tack Masking Tapes / 20mm width, Pack .....	16
H-MASKT-6B	Low Tack Masking Tapes / 6mm width, Box .....	16
H-MASKT-6P	Low Tack Masking Tapes / 6mm width, Pack .....	16
H-MASKT-SET	Low Tack Masking Tape Set .....	16
H-NF-009	Black Nut File for Guitar / 0.009".....	8
H-NF-010	Black Nut File for Guitar / 0.010".....	8
H-NF-010DC	Diamond-combo Black Nut File / 0.010" .....	9
H-NF-012	Black Nut File for Guitar / 0.012".....	8
H-NF-012DC	Diamond-combo Black Nut File / 0.012" .....	9
H-NF-013	Black Nut File for Guitar / 0.013".....	8
H-NF-013DC	Diamond-combo Black Nut File / 0.013" .....	9
H-NF-016	Black Nut File for Guitar / 0.016".....	8
H-NF-016DC	Diamond-combo Black Nut File / 0.016" .....	9
H-NF-024	Black Nut File for Guitar / for Ukulele / 0.024".....	8
H-NF-028	Black Nut File for Guitar / for Ukulele / 0.028".....	8
H-NF-032	Black Nut File for Guitar / for Ukulele / 0.032".....	8
H-NF-036	Black Nut File for Guitar / for Ukulele / 0.036".....	8
H-NF-040	Black Nut File for Guitar / 0.040".....	8
H-NF-042	Black Nut File for Guitar / 0.042".....	8
H-NF-046	Black Nut File for Guitar / for Bass / 0.046" .....	8
H-NF-050	Black Nut File for Guitar / for Bass / 0.050" .....	8
H-NF-054	Black Nut File for Guitar / for Bass / 0.054" .....	8
H-NF-065	Black Nut File for Guitar / for Bass / 0.065" .....	8
H-NF-075	Black Nut File for Guitar / for Bass / 0.075" .....	8
H-NF-085	Black Nut File for Bass / 0.085" .....	8
H-NF-090	Black Nut File for Bass / 0.090" .....	8
H-NF-105	Black Nut File for Bass / 0.105" .....	8
H-NF-130	Black Nut File for Bass / 0.130" .....	8
H-NF-AG	Black Nut File Set for Acoustic Guitars.....	8
H-NF-CG	Black Nut File Set for Classical Guitars.....	8
H-NF-EB	Black Nut File Set for Electric Basses .....	8
H-NF-EG009	Black Nut File Set for Electric Guitars .....	8
H-NF-EG010	Black Nut File Set for Electric Guitars .....	8
H-NF-H	Black Nut File Aluminum holder .....	8
H-NF-UK	Black Nut File Set for Ukulele .....	8
H-NSG	2-way Neck Support .....	48
H-NWT2	HOSCO Nut Work Table .....	6
H-NWT-600D	HOSCO Nut Work Table Diamond Sheet .....	6
H-RG2	Fingerboard Radius Gauge .....	44
H-SG-G	Step Gauge for Guitar .....	42
H-SGSW	String Guide Saw.....	7
H-SG-U	Step Gauge for Ukulele and Mandolin.....	42
H-TB1V	Roll-up tool bag .....	49
H-TB2	Guitar Tech Bag .....	49
HT-MKIT	Hygrometer / Thermometer Case mout kit only .....	57
H-TO-15	HOSCO Tool Oil .....	51
H-TRW+	Phillips Head Truss Rod Wrench .....	47
HWC-3739	Professional Care Cloth for superior finish .....	55
H-ZONE	Zone File set .....	22
H-ZONE-H	Zone File for High fret area .....	22
H-ZONE-L	Zone File for Low fret area .....	22
H-ZONE-HD	Zone File Diamond Sheet for ZONE-H .....	22
H-ZONE-LD	Zone File Diamond Sheet for ZONE-L .....	22

IDP-156	Handy-type Dual Diamond Plates / #150 / 600 .....	51
IDP-410	Handy-type Dual Diamond Plates / #400 / 1000 .....	51
IDS-1200	Mini Self-adhesive Diamond Sheets / #1200.....	16, 37
IDS-150	Mini Self-adhesive Diamond Sheets / #150 .....	16, 37
IDS-300	Mini Self-adhesive Diamond Sheets / #300 .....	16, 37
IDS-600	Mini Self-adhesive Diamond Sheets / #600 .....	16, 37

## K

KCR100	Kovax Rolled Sandpapers / #100.....	16, 37
KCR120	Kovax Rolled Sandpapers / #120.....	16, 37
KCR150	Kovax Rolled Sandpapers / #150.....	16, 37
KCR240	Kovax Rolled Sandpapers / #240.....	16, 37
KCR320	Kovax Rolled Sandpapers / #320.....	16, 37
KCR400	Kovax Rolled Sandpapers / #400.....	16, 37
KCR600	Kovax Rolled Sandpapers / #600.....	16, 37
KFRP1200	Kovax Finish Repairing Papers / #1200 .....	36
KFRP1500	Kovax Finish Repairing Papers / #1500 .....	36
KFRP2000	Kovax Finish Repairing Papers / #2000 .....	36
KFRP2500	Kovax Finish Repairing Papers / #2500 .....	36
KFRP3000	Kovax Finish Repairing Papers / #3000 .....	36
KFRP800	Kovax Finish Repairing Papers / #800 .....	36
KFRP-KIT2	Kovax Finish Repair Papers and Blocks Set 2 .....	36
KFRP-KIT6	Kovax Finish Repair Papers and Blocks Set 6 .....	36
KFRP-RBC	Kovax Rubber Blocks for KFRP, curved surface .....	36
KFRP-RBF	Kovax Rubber Blocks for KFRP, flat surface .....	36
KSC1000	Kovax Water Proof Sandpapers / #1000 .....	37
KSC1200	Kovax Water Proof Sandpapers / #1200 .....	37
KSC1500	Kovax Water Proof Sandpapers / #1500 .....	37
KSC180	Kovax Water Proof Sandpapers / #180 .....	37
KSC2000	Kovax Water Proof Sandpapers / #2000 .....	37
KSC240	Kovax Water Proof Sandpapers / #240 .....	37
KSC320	Kovax Water Proof Sandpapers / #320 .....	37
KSC400	Kovax Water Proof Sandpapers / #400 .....	37
KSC600	Kovax Water Proof Sandpapers / #600 .....	37
KSC800	Kovax Water Proof Sandpapers / #800 .....	37

## S

SSS-120	SHINEX Sanding Sheet / #120 .....	35
SSS-1500	SHINEX Sanding Sheet / #1500 .....	35
SSS-240	SHINEX Sanding Sheet / #240 .....	35
SSS-3000	SHINEX Sanding Sheet / #3000 .....	35
SSS-400	SHINEX Sanding Sheet / #400 .....	35
SSS-600	SHINEX Sanding Sheet / #600 .....	35
SSS-80	SHINEX Sanding Sheet / #80.....	35
SSS-800	SHINEX Sanding Sheet / #800 .....	35
SSS-SET	SHINEX Sanding Sheet Set .....	35

## T

TDS100	Self-adhesive Diamond Sheets / #100 .....	16, 37
TDS400	Self-adhesive Diamond Sheets / #400 .....	16, 37

TL-BF3	Nut and Saddle Shaping File Set .....	6
TL-BF5LR	Line Round File Set of 5 .....	9, 33, 52
TL-BFFL	Nut and Saddle Shaping File Flat .....	6
TL-BFHR	Nut and Saddle Shaping File Half-round.....	6
TL-BFLR08	Line Round Files 0.8mm .....	9, 33
TL-BFLR12	Line Round Files 1.2mm .....	9, 33
TL-BFLR15	Line Round Files 1.5mm .....	9, 33
TL-BFLR20	Line Round Files 2.0mm .....	9, 33
TL-BFLR25	Line Round Files 2.5mm .....	9, 33
TL-BFTRI	Nut and Saddle Shaping File Triangle .....	6
TL-CP-FL100	Flat CP File / 100mm .....	32
TL-CP-FL150	Flat CP File / 150mm .....	32
TL-CP-FL150W	Flat CP File / 150mm .....	32
TL-CP-FL200	Flat CP File / 200mm .....	32
TL-CP-HR100	Half-round CP File / 100mm .....	32
TL-CP-HR150	Half-round CP File / 150mm .....	32
TL-CP-HR150W	Half-round CP File / 150mm .....	32
TL-CP-HR200	Half-round CP File / 200mm .....	32
TL-DB2-7086	Step Drill Bits $\phi$ 7.0/8.6 .....	12
TL-DB2-7899	Step Drill Bits $\phi$ 7.8/9.9 .....	12
TL-DF100	Feather Edge File .....	34
TL-DF100DA	Feather Edge Diamond File / 100mm .....	34
TL-DF75DA	Feather Edge Diamond File / 75mm .....	34
TL-DIA5	200-grit Diamond File Set .....	34
TL-FC190	Fret Cutters for Nickel silver Fretwire .....	18
TL-FC28S	Fret Cutters for Stainless steel Fretwire .....	18
TL-FE1	Fret-end Dressing Files / Small.....	25
TL-FE2	Fret-end Dressing Files / Medium .....	25
TL-FE2HC	Fret-end Dressing Files / for Stainless Medium .....	25
TL-FE3	Fret-end Dressing Files / Large .....	25
TL-FE3HC	Fret-end Dressing Files / for Stainless Large.....	25
TL-FF1	Fret Crown Files Small .....	24
TL-FF2	Fret Crown Files Medium .....	24
TL-FF3	Fret Crown Files Large .....	24
TL-FFD600	3 in 1 Diamond Fret Crown File .....	23
TL-FFLD12	Diamond fret leveling file (R=1/R=2) .....	23
TL-FFLD23	Diamond fret leveling file (R=2/R=3) .....	23
TL-FL160S	Fret Leveling File for Regular Fretwire.....	22
TL-FL160SHC	Fret Leveling File for Stainless steel Fretwire .....	22
TL-FS10	Fret Setter .....	20
TL-H-AZE60	Azebiki Saw .....	27
TL-H-DS150	Dozuki Saw (Back Saws) / 150mm .....	27
TL-H-DS240	Dozuki Saw (Back Saws) / 240mm .....	27
TL-H-FCSW103	Fine Cut Saw / 0.1mm .....	26
TL-H-FCSW2	Fine Cut Saw / 0.2mm .....	26
TL-H-FCSW3	Fine Cut Saw / 0.3mm .....	26
TL-H-FL120	Flush Cutting Saw .....	27
TL-H-FSW050	Fret Slot Saw / Carbon steel / 0.50mm.....	14
TL-H-FSW050H	Fret Slot Saw / YSS / 0.50mm.....	14
TL-H-FSW053	Fret Slot Saw / Carbon steel / 0.53mm .....	14
TL-H-FSW053H	Fret Slot Saw / YSS / 0.53mm.....	14
TL-H-FSW057	Fret Slot Saw / Carbon steel / 0.57mm.....	14
TL-H-FSW057H	Fret Slot Saw / YSS / 0.57mm.....	14
TL-H-FSW060	Fret Slot Saw / Carbon steel / 0.60mm .....	14
TL-H-FSW060H	Fret Slot Saw / YSS / 0.60mm.....	14

TL-HMF-S	Octagonal Shape Hammer.....	20	TL-INM12	Japanese Chisel (Tataki-Nomi) /12mm .....	31
TL-HMT-L	Japanese Hammer (Twin Heads), Large .....	20	TL-INM15	Japanese Chisel (Tataki-Nomi) /15mm .....	31
TL-HMT-S	Japanese Hammer (Twin Heads), Small .....	20	TL-INM18	Japanese Chisel (Tataki-Nomi) /18mm .....	31
TL-H-RSAW	Bracing Saw .....	27	TL-INM21	Japanese Chisel (Tataki-Nomi) /21mm .....	31
TL-H-SCSW040	Fret Slot Cleaning Saw / 0.40mm .....	14	TL-INM24	Japanese Chisel (Tataki-Nomi) /24mm .....	31
TL-H-SCSW050	Fret Slot Cleaning Saw / 0.50mm .....	14	TL-INM3	Japanese Chisel (Tataki-Nomi) /3mm .....	31
TL-H-SCSWD04	Fret Slot Cleaning Saw / Ryoba / 0.40mm .....	14	TL-INM6	Japanese Chisel (Tataki-Nomi) /6mm .....	31
TL-H-SCSWD05	Fret Slot Cleaning Saw / Ryoba / 0.50mm .....	14	TL-INM9	Japanese Chisel (Tataki-Nomi) /9mm .....	31
TL-H-VP	Hand Jig Saw .....	26, 52	TL-INM-SET4	Japanese Chisel (Tataki-Nomi) set .....	31
TL-I-6S	Kogatana knife set.....	30	TL-I-UNRYU10D	Fancy Kiridashi knife "UNRYU"/Double / 10mm .....	28
TL-I-CAKD	Wood Curving Knife .....	29	TL-I-UNRYU10L	Fancy Kiridashi knife "UNRYU"/ left / 10mm .....	28
TL-IDH-1	Table-top type Diamond Hone / #150 .....	51	TL-I-UNRYU10R	Fancy Kiridashi knife "UNRYU"/ right / 10mm .....	28
TL-IDH-2	Table-top type Diamond Hone / #300 .....	51	TL-I-UNRYU12D	Fancy Kiridashi knife "UNRYU"/ Double / 12mm.....	28
TL-IDH-3	Table-top type Diamond Hone / #600 .....	51	TL-I-UNRYU12L	Fancy Kiridashi knife "UNRYU"/ left / 12mm.....	28
TL-IGS15	Japanese Gouges / 15mm wide Blade .....	30, 53	TL-I-UNRYU12R	Fancy Kiridashi knife "UNRYU"/ right / 12mm .....	28
TL-IGS9	Japanese Gouges / 9mm wide Blade.....	30, 53	TL-I-UNRYU15D	Fancy Kiridashi knife "UNRYU"/ Double / 15mm.....	28
TL-I-H10A	Wooden Handles for Kiridashi knife / 10mm .....	29	TL-I-UNRYU15L	Fancy Kiridashi knife "UNRYU"/ left / 15mm.....	28
TL-I-H12A	Wooden Handles for Kiridashi knife / 12mm .....	29	TL-I-UNRYU15R	Fancy Kiridashi knife "UNRYU"/ right / 15mm .....	28
TL-I-H15A	Wooden Handles for Kiridashi knife / 15mm .....	29	TL-I-UNRYU18D	Fancy Kiridashi knife "UNRYU"/ Double / 18mm.....	28
TL-I-H3A	Wooden Handles for Kiridashi knife / 3mm .....	29	TL-I-UNRYU18L	Fancy Kiridashi knife "UNRYU"/ left / 18mm.....	28
TL-I-H6A	Wooden Handles for Kiridashi knife / 6mm .....	29	TL-I-UNRYU18R	Fancy Kiridashi knife "UNRYU"/ right / 18mm .....	28
TL-I-H8A	Wooden Handles for Kiridashi knife / 8mm .....	29	TL-I-UNRYU3D	Fancy Kiridashi knife "UNRYU"/ Double / 3mm .....	28
TL-I-K10D	Kiridashi knife / Bevel: Double / 10mm .....	29	TL-I-UNRYU3L	Fancy Kiridashi knife "UNRYU"/ left / 3mm .....	28
TL-I-K10L	Kiridashi knife / Bevel: Left / 10mm .....	29	TL-I-UNRYU3R	Fancy Kiridashi knife "UNRYU"/ right / 3mm .....	28
TL-I-K10R	Kiridashi knife / Bevel: Right / 10mm .....	29	TL-I-UNRYU6D	Fancy Kiridashi knife "UNRYU"/ Double / 6mm .....	28
TL-I-K12D	Kiridashi knife / Bevel: Double / 12mm .....	29	TL-I-UNRYU6L	Fancy Kiridashi knife "UNRYU"/ left / 6mm .....	28
TL-I-K12L	Kiridashi knife / Bevel: Left / 12mm .....	29	TL-I-UNRYU6R	Fancy Kiridashi knife "UNRYU"/ right / 6mm .....	28
TL-I-K12R	Kiridashi knife / Bevel: Right / 12mm .....	29	TL-I-UNRYU8D	Fancy Kiridashi knife "UNRYU"/ Double / 8mm .....	28
TL-I-K15D	Kiridashi knife / Bevel: Double / 15mm .....	29	TL-I-UNRYU8L	Fancy Kiridashi knife "UNRYU"/ left / 8mm .....	28
TL-I-K15L	Kiridashi knife / Bevel: Left / 15mm .....	29	TL-I-UNRYU8R	Fancy Kiridashi knife "UNRYU"/ right / 8mm .....	28
TL-I-K15R	Kiridashi knife / Bevel: Right / 15mm .....	29	TL-JSW490	Super Q Jewelers Saw Handle .....	13
TL-I-K18D	Kiridashi knife / Bevel: Double / 18mm .....	29	TL-JSWB-0	Jewelers Saw Super Q Blade / 0.36 x 0.18mm .....	13
TL-I-K18L	Kiridashi knife / Bevel: Left / 18mm .....	29	TL-JSWB-1	Jewelers Saw Super Q Blade / 0.44 x 0.22mm .....	13
TL-I-K18R	Kiridashi knife / Bevel: Right / 18mm .....	29	TL-JSWB-2	Jewelers Saw Super Q Blade / 0.52 x 0.26mm .....	13
TL-I-K3D	Kiridashi knife / Bevel: Double / 3mm .....	29	TL-JSWB-2/0	Jewelers Saw Super Q Blade / 0.56 x 0.28mm .....	13
TL-I-K3L	Kiridashi knife / Bevel: Left / 3mm.....	29	TL-JSWB-4/0	Jewelers Saw Super Q Blade / 0.60 x 0.30mm .....	13
TL-I-K3R	Kiridashi knife / Bevel: Right / 3mm .....	29	TL-JSWB-6/0	Jewelers Saw Super Q Blade / 0.70 x 0.34mm .....	13
TL-I-K6D	Kiridashi knife / Bevel: Double / 6mm .....	29	TL-KUJIRI-S	Japanese Kujiri .....	26, 52
TL-I-K6L	Kiridashi knife / Bevel: Left / 6mm.....	29	TL-MC11	Micro Chisel / Width : 1.1mm .....	31, 52
TL-I-K6R	Kiridashi knife / Bevel: Right / 6mm .....	29	TL-MC22	Micro Chisel / Width : 2.2mm .....	31, 52
TL-I-K8D	Kiridashi knife / Bevel: Double / 8mm .....	29	TL-NC1800C	Ceramic Combination Stones / #320/#800 .....	50
TL-I-K8L	Kiridashi knife / Bevel: Left / 8mm.....	29	TL-NC2800C	Ceramic Combination Stones / #280/#1500 .....	50
TL-I-K8R	Kiridashi knife / Bevel: Right / 8mm .....	29	TL-NC3800C	Ceramic Combination Stones / #1000/#3000 .....	50
TL-I-KM21	High-end Fancy Kiridashi knife .....	28	TL-NC4800C	Ceramic Combination Stones / #1000/#6000 .....	50
TL-I-KU10D	Kuri knife / Double.....	30	TL-NF-010	Edge-Cut Nut File for Guitar / .010" .....	10
TL-I-KU10L	Kuri knife / Left .....	30	TL-NF-013	Edge-Cut Nut File for Guitar / .013" .....	10
TL-I-KU10R	Kuri knife / Right.....	30	TL-NF-016	Edge-Cut Nut File for Guitar / .016" .....	10
TL-I-KU21	High-end Fancy Kiridashi knife .....	28	TL-NF-024	Edge-Cut Nut File for Guitar / .024" .....	10
TL-I-KUKD	Kuri knife with Wooden Handle / Double .....	29, 53	TL-NF-028	Edge-Cut Nut File for Guitar / .028" .....	10
TL-I-KUKL	Kuri knife with Wooden Handle / Left .....	29, 53	TL-NF-032	Edge-Cut Nut File for Guitar / .032" .....	10
TL-I-KUKR	Kuri knife with Wooden Handle / Right .....	29, 53	TL-NF-036	Edge-Cut Nut File for Guitar / .036" .....	10
			TL-NF-042	Edge-Cut Nut File for Guitar / .042" .....	10
			TL-NF-046	Edge-Cut Nut File for Guitar / .046" .....	10
			TL-NF-050	Edge-Cut Nut File for Guitar / .050" .....	10
			TL-NF-056	Edge-Cut Nut File for Guitar / .056" .....	10
			TL-NF10	Edge-Cut Nut Files / Set of 10 .....	10
			TL-NF11	Edge-Cut Nut Files / Set of 11 .....	10



TL-NF3A	Double Edge Nut Files Set / for Acoustic Guitar .....	10
TL-NF3B	Double Edge Nut Files Set / for Bass.....	10
TL-NF3C	Double Edge Nut Files Set / for Classical Guitar .....	10
TL-NF3E	Double Edge Nut Files Set / for Electric Guitar.....	10
TL-NF3U	Double Edge Nut Files Set / for Ukulele.....	10
TL-RU150	Rulers w/ Inch Conversion Table / 150mm .....	44
TL-RU300	Rulers w/ Inch Conversion Table / 300mm .....	44
TL-RU600	Rulers w/ Inch Conversion Table / 600mm .....	44
TL-RU-PG	Profiling Gauge .....	45
TL-RU-PR	Protractor .....	44
TL-RU-SQ75	Mini Stainless Square .....	45
TL-RU-TA	Taper Gauge .....	45
TL-RU-TG	Thickness Gauge.....	45
TL-SCR-1C	Wide Scraper / Curved shape .....	39
TL-SCR-1S	Wide Scraper / Straight shape .....	39
TL-SCR-2	Standard Scraper Set / Set of 2 shapes .....	39, 53
TL-SCR-5	Standard Scraper Set / Set of 5 shapes .....	39, 53
TL-SF2	Saddle Slot File / Thickness : 2mm .....	11
TL-SF2.5	Saddle Slot File / Thickness : 2.5mm .....	11
TL-SF3	Saddle Slot File / Thickness : 3mm .....	11
TL-SFF5	Standard File Set / Secound cut File Set .....	34
TL-SSF5	Swiss-cut Precision Needle File Set .....	34
TL-S-SR200	Wood Saw Rasps / 200mm long blade .....	33
TL-S-SR250	Wood Saw Rasps / 250mm long blade .....	33
TL-S-SRD-RB	Saw Rasps Replacement blade.....	33
TL-ST1200	Ceramic Single Stone / #1200 .....	50
TL-ST800	Ceramic Single Stone / #800 .....	50
TL-TC10	Fret Pullers / Blade width:5mm .....	19
TL-TC5	Fret Pullers / Blade width:10mm.....	19
TL-VNF4	Edge-Cut Violin Nut File Set .....	11, 52
TL-VNF4/E	Edge-Cut Violin Nut File for E string .....	11, 52
TWSB-1	2 Way Sanding Block / 184R/ 241R.....	17, 38
TWSB-12U	Sanding Block for Ukuleles / 305R (12") / flat .....	17, 38
TWSB-16U	Sanding Block for Ukuleles / 406R (16") / flat .....	17, 38
TWSB-2	2 Way Sanding Block / 254R / 305R .....	17, 38
TWSB-3	2 Way Sanding Block / 356R / 406R .....	17, 38
TWSB-4	2 Way Sanding Block / 381R / 508R .....	17, 38

---

## W

---

WRE-1.27	Hex Wrenches / 1.27mm (.050") .....	47
WRE-1.5	Hex Wrenches / 1.5mm .....	47
WRE-1.57	Hex Wrenches / 1.57mm (1/16") .....	47
WRE-2.0	Hex Wrenches / 2.0mm .....	47
WRE-2.5	Hex Wrenches / 2.5mm .....	47
WRE-3.0	Hex Wrenches / 3.0mm .....	47
WRE-4.0	Hex Wrenches / 4.0mm .....	47
WRE-5.0	Hex Wrenches / 5.0mm .....	47
WRE-7.0	Hex Wrenches / 7.0mm .....	47
WRE-8.0	Hex Wrenches / 8.0mm .....	47
WRE-I14	Truss Rod Wrenches / 6.35mm (1/4") .....	47
WRE-I516	Truss Rod Wrenches / 7.93mm(5/16" ).....	47

***HOSCO***<sup>®</sup>

The specification and price are subject to change without notice.

20230623